

*American Dream*

FLEETWOOD, RV

**WIDE BODY**

**2000  
owner's manual**



*American Dream*  
WIDE BODY FLEETWOOD RV

**2000**

### MAP OF FLEETWOOD'S DECATUR, INDIANA FACILITIES

- A = PLANT #44 MOTOR HOME (HERITAGE, EAGLE, DREAM, TRADITION, DISCOVERY, VISION)
- B = PLANT #52 MOTOR HOME (STORM, FLAIR, MONTARA, WALKABOUT, RALLEY, SEARCHER, C-SPORT, AND CHEVROLET FLYER)
- C = AMERICAN COACH SERVICE CENTER WITH OVERNIGHT PARKING (EAGLE, DREAM, TRADITION, FLYERS, LIMITED)
- D = PLANT #91 REGIONAL SERVICE CENTER (ALL OTHER FLEETWOOD MOTOR HOMES)
- E = PLANT 343 GOLDSHIELD FIBERGLASS

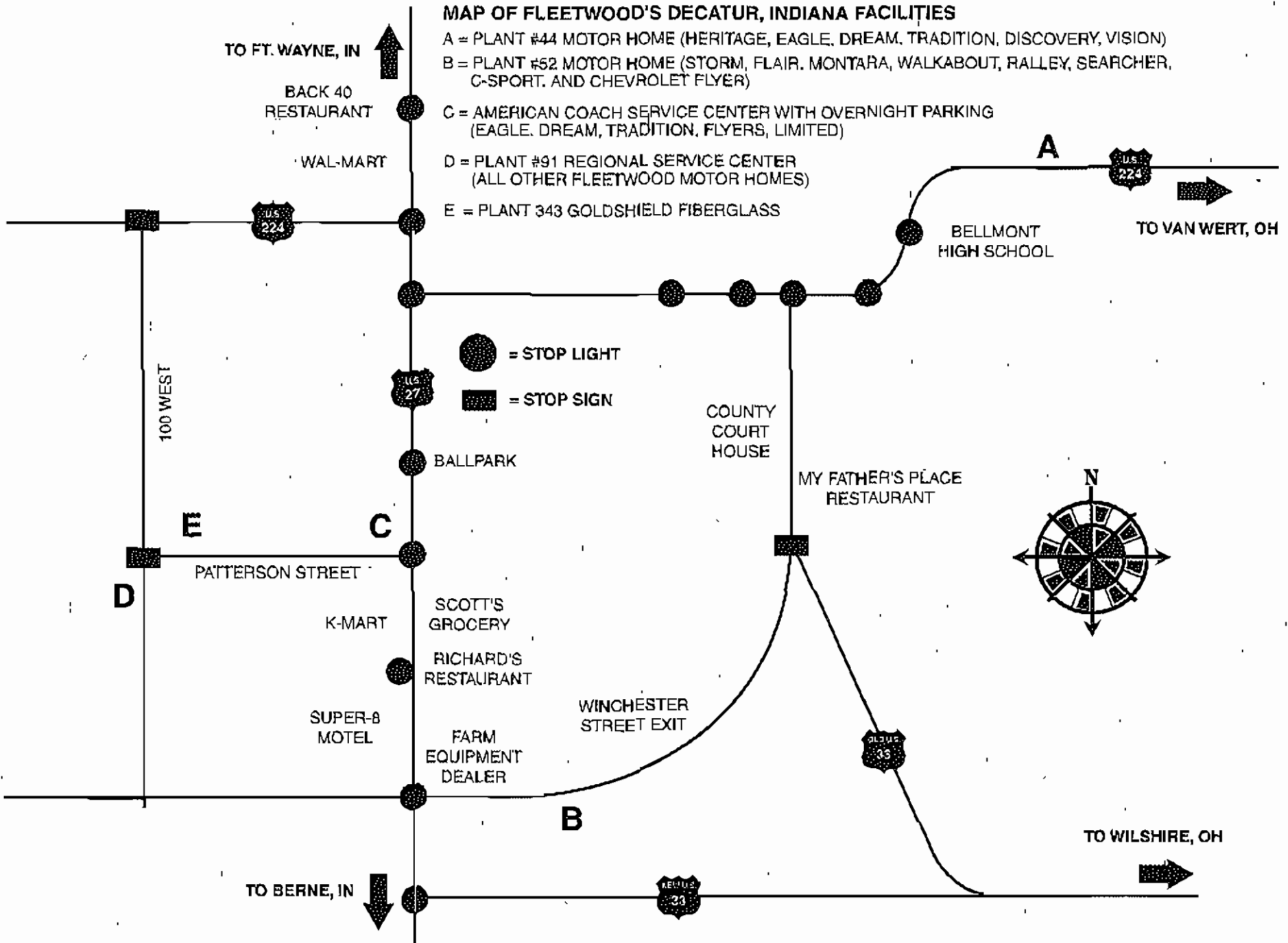

TO FT. WAYNE, IN ↑

BACK 40 RESTAURANT

WAL-MART

100 WEST

E

PATTERSON STREET

D

K-MART

SUPER-8 MOTEL

TO BERNE, IN ↓

● = STOP LIGHT  
 ■ = STOP SIGN

BALLPARK

SCOTT'S GROCERY

RICHARD'S RESTAURANT

FARM EQUIPMENT DEALER

COUNTY COURT HOUSE

MY FATHER'S PLACE RESTAURANT

WINCHESTER STREET EXIT

B

US 31

A

BELLMONT HIGH SCHOOL

TO VAN WERT, OH →

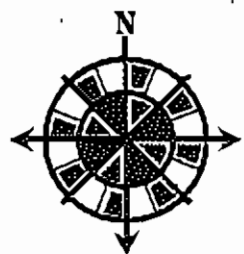

TO WILSHIRE, OH →

# AMERICAN COACH ASSOCIATION

*The association of AMERICAN EAGLE, AMERICAN DREAM,  
AMERICAN TRADITION and LIMITED*

## *Motorcoach Owners*

---

WELCOME TO THE WORLD OF AMERICAN COACH ASSOCIATION! We can appreciate how much you are enjoying your new coach because we, too, own EAGLES, DREAMS, TRADITIONS AND LIMITEDS — and we invite you to join us.

Why should you join? Because it's fun, that's why. There is camaraderie in meeting other owners and, with all due modesty, we're a darn nice bunch! There are also rallies, a newsletter, and regional chapters covering most of the USA.

AMERICAN COACH ASSOCIATION was formed to encourage camaraderie and the exchange of information not only among members but with the manufacturer as well. It is not sponsored by Fleetwood Motor homes.

AMERICAN COACH ASSOCIATION holds rallies twice a year in areas that are interesting and / or scenic. Fun and informative, they feature brief seminars to entertain you or keep you informed about your coach; opportunities to see ideas that owners have incorporated in their coaches; optional tours and activities; the "latest info" from Fleetwood's American Coach Division; and new coaches displayed by dealers.

AMERICAN COACH ASSOCIATION members also receive a newsletter which gives information on upcoming rallies and news from the regional chapters, including information on their rallies. And of course, new members are always recognized and welcomed in the newsletter.

Regional chapters foster fun and friendship among owners in a specific area. Members of AMERICAN COACH ASSOCIATION from outside the area are invited to participate in a chapter's rally if they happen to be in that area, or you may even join more than one chapter.

So what does it cost to join this elite group? A mere pittance! Initiation fee is \$14 and annual membership is \$36, prorated from JULY (see enclosed application). Now you too, can be a member of AMERICAN COACH ASSOCIATION — just fill out the application and send it with your check to the address shown on the form.

All kidding aside, we really would like to have you join our group. We know you're enjoying your elegant new coach and we'll look forward to getting acquainted.

Sincerely, AMERICAN COACH ASSOCIATION MEMBERS









# American Coach Chapter of FMCA

The Family Motor Coach Association

Dear Owner(s) of an American Eagle, American Dream, American Tradition or Limited Motor Home:

Congratulations on choosing an American Coach Product, we are sure that you will enjoy your coach and we would like to invite you to join our organization. The American Coach Chapter (ACC) of the Family Motor Coach Association (FMCA) was formed to allow owners of motor homes produced by the American Coach Division of Fleetwood Enterprises an opportunity to gather at a Pre-Convention Rally, then travel to and be parked as a group at the National FMCA Conventions. FMCA holds two National Conventions each year, one in the Spring and the other in late Summer or early Fall. The American Coach service team attends our rallies to provide service and repair and one or more dealers attend to display, demonstrate and sell new coaches.

To be eligible to join, you must own at least a one-third share in an American Eagle, American Dream, American Tradition or Limited motor home and be a member in good standing of FMCA.

Please consider joining our group. An application is provided below, fill it out and mail it as indicated, or give it and your check to a Chapter member.

---

## APPLICATION FOR MEMBERSHIP IN THE AMERICAN COACH CHAPTER OF FMCA

NAME \_\_\_\_\_ NICKNAME \_\_\_\_\_

NAME \_\_\_\_\_ NICKNAME \_\_\_\_\_

MAILING ADDRESS \_\_\_\_\_

CITY \_\_\_\_\_ STATE \_\_\_\_\_ ZIP \_\_\_\_\_

TELEPHONE (     ) \_\_\_\_\_

Membership Fee     \$5.00

Annual Dues     \$12.00

COACH TYPE \_\_\_\_\_ YEAR \_\_\_\_\_

Total Amount     \$17.00

FMCA # \_\_\_\_\_ E-MAIL ADDRESS \_\_\_\_\_

MAIL WITH YOUR CHECK TO: ACC/FMCA  
% Dick & Betty Fno  
7408 Chaco Rd. NE  
Albuquerque, NM 87109



# LIMITED ONE-YEAR/THREE-YEAR WARRANTY

FOR MOTOR HOMES MANUFACTURED BY SUBSIDIARIES OF FLEETWOOD ENTERPRISES, INC.  
SOLD IN THE UNITED STATES AND CANADA

## COVERAGE PROVIDED

Your new motor home, including the structure, plumbing, heating and electrical systems, and all appliances and equipment installed by the manufacturer, is warranted under normal use to be free from manufacturing defects in material or workmanship. Defects or damage to paint, graphics, exterior materials, upholstery or other appearance items that may occur prior to delivery are usually corrected during the inspection process at the manufacturing plant or the dealership.

The warranty extends to the first retail purchaser and his transferee(s) and begins on the date of original retail delivery or the date the motor home is first placed into service as a rental, commercial or demonstrator unit (whichever occurs first). The warranty extends for the following periods:

1. For all defects (other than structural) the warranty extends for a period of one year from such date or until the unit has received 15,000 total miles of use as determined by the mileage shown on the odometer (whichever occurs first).
2. For structural defects, 3 years; structural defects are limited to the following: roof structure, sub-floor structure, exterior walls, interior walls and ceilings.

Written notice of defects must be given to the selling dealer or manufacturer not later than ten (10) days after the expiration of the warranty period.

## OWNER'S OBLIGATIONS

The owner is responsible for normal maintenance as described in the Owner's Manual, however, minor adjustments (such as adjustments to the interior or exterior doors, LP regulator pressure, cabinet latches, TV antenna control, etc.) will be performed by the dealer during the first 90 days of warranty coverage. Thereafter, such adjustments are the responsibility of the owner as normal maintenance unless required as a direct result of repair or replacement of a defective part under this warranty.

If a problem occurs which the owner believes is covered by this warranty, the owner shall contact the selling dealer, or other authorized dealer, giving him sufficient information to resolve the matter. The owner shall deliver the motor home to the dealer or manufacturing plant location for warranty service.

## DEALER'S OBLIGATIONS

By agreement with the manufacturer, the dealer is obligated to maintain the motor home prior to retail sale, to perform a detailed pre-delivery inspection and to repair or replace any parts necessary to correct defects in material or workmanship.

## WHEN THE DEALER DOES NOT RESOLVE THE PROBLEM

If the dealer is unable or unwilling to resolve a problem which the owner is convinced is covered by the warranty, he should contact the manufacturing plant at the address listed below and provide the manufacturer with a description in writing of the problem and attempts made to resolve it.

## MANUFACTURING PLANT OBLIGATIONS

Upon receipt of notice of a claim, where the dealer was unable or unwilling to resolve the problem, the manufacturing plant will repair or replace any parts necessary to correct defects in material or workmanship or will take other appropriate action as may be required.

## WHEN THE MANUFACTURING PLANT DOES NOT RESOLVE THE PROBLEM

If the representatives of the manufacturing plant are unable to resolve the problem and the owner is convinced that it is covered by the warranty, the owner should call the toll-free number listed below to describe the problem and the attempts made to resolve it.

## WHAT IS NOT COVERED BY THE EXPRESS WARRANTY

### THIS WARRANTY DOES NOT COVER

1. THE AUTOMOTIVE SYSTEM (INCLUDING THE CHASSIS AND DRIVE TRAIN), TIRES AND BATTERIES, WHICH ARE COVERED BY THE SEPARATE WARRANTIES OF THE RESPECTIVE MANUFACTURERS OF THESE COMPONENTS.
2. DEFECTS CAUSED BY OR ATTRIBUTED TO:
  - A. ABUSE, MISUSE, NEGLIGENCE OR ACCIDENT;
  - B. FAILURE TO COMPLY WITH INSTRUCTIONS CONTAINED IN THE OWNER'S MANUAL;
  - C. ALTERATION OR MODIFICATION OF THE MOTOR HOME;
  - D. ENVIRONMENTAL CONDITIONS (SALT, HAIL, CHEMICALS IN THE ATMOSPHERE, ETC.)
3. NORMAL DETERIORATION DUE TO WEAR OR EXPOSURE, SUCH AS FADING OF FABRICS OR DRAPES, CARPET WEAR, ETC.
4. NORMAL MAINTENANCE AND SERVICE ITEMS, SUCH AS LIGHT BULBS, FUSES, WIPER BLADES, LUBRICANTS, ETC.
5. MOTOR HOMES ON WHICH THE ODOMETER READING HAS BEEN ALTERED.
6. TRANSPORTATION TO AND FROM DEALER OR MANUFACTURING PLANT LOCATION, LOSS OF TIME, INCONVENIENCE, COMMERCIAL LOSS, LOSS OF USE, TOWING CHARGES, BUS FARES, VEHICLE RENTAL, INCIDENTAL CHARGES SUCH AS TELEPHONE CALLS OR HOTEL BILLS, OR OTHER INCIDENTAL OR CONSEQUENTIAL DAMAGES.

SOME STATES DO NOT ALLOW THE EXCLUSION OR LIMITATION OF INCIDENTAL OR CONSEQUENTIAL DAMAGES, SO THE ABOVE LIMITATION OR EXCLUSION MAY NOT APPLY TO YOU.

THIS WARRANTY GIVES YOU SPECIFIC LEGAL RIGHTS, AND YOU MAY ALSO HAVE OTHER RIGHTS WHICH VARY FROM STATE TO STATE.

THE MANUFACTURER IS NOT RESPONSIBLE FOR ANY UNDERTAKING, REPRESENTATION OR WARRANTY MADE BY ANY DEALER OR OTHER PERSON BEYOND THOSE EXPRESSLY SET FORTH IN THIS WARRANTY.

Brand Name: \_\_\_\_\_ Model: \_\_\_\_\_ Serial No. \_\_\_\_\_

### FOR CUSTOMER SERVICE ASSISTANCE:

Fleetwood's American Coach Division  
Parts & Service  
1420 West Patterson Street  
Decatur, IN 46773

Service (800) 435-7345  
Parts (800) 344-3245  
Fax (219) 728-2951

### CORPORATE HEADQUARTERS:

Motor Home Division  
Fleetwood Enterprises, Inc.  
P.O. Box 7638  
Riverside, CA 92513-7638  
(909) 351-3500

## IMPORTANT NOTICE

Our forest product suppliers have advised that urea-formaldehyde is used in the production of particle board, hardwood plywood or paneling which they supply us and which we utilize in our finished product. These suppliers have requested that we communicate this to our customers.

For your information, we are reproducing samples of statements which have been provided to us by our suppliers.

**WARNING:** THIS PRODUCT IS MANUFACTURED WITH UREA-FORMALDEHYDE RESIN. FORMALDEHYDE VAPOR MAY IN SOME PEOPLE CAUSE HEADACHES, EYE, NOSE AND THROAT IRRITATION, AND AGGRAVATION OF ALLERGIES AND RESPIRATORY PROBLEMS, SUCH AS ASTHMA. PROPER VENTILATION SHOULD REDUCE THE RISK OF SUCH PROBLEMS.

*Champion International Corporation*

**WARNING: IRRITANT:** THIS PRODUCT CONTAINS A UREA-FORMALDEHYDE RESIN AND MAY RELEASE FORMALDEHYDE VAPORS IN LOW CONCENTRATIONS. FORMALDEHYDE CAN BE IRRITATING TO THE EYES AND UPPER RESPIRATORY SYSTEM OF ESPECIALLY SUSCEPTIBLE PERSONS SUCH AS THOSE WITH ALLERGIES OR RESPIRATORY AILMENTS. USE WITH ADEQUATE VENTILATION. IF SYMPTOMS DEVELOP, CONSULT YOUR PHYSICIAN.

*Georgia-Pacific Corporation*

**WARNING:** THIS PRODUCT IS MANUFACTURED WITH A UREA-FORMALDEHYDE RESIN AND WILL RELEASE SMALL QUANTITIES OF FORMALDEHYDE. FORMALDEHYDE LEVELS IN THE INDOOR AIR CAN CAUSE TEMPORARY EYE AND RESPIRATORY IRRITATION, AND MAY AGGRAVATE RESPIRATORY CONDITIONS OR ALLERGIES. VENTILATION WILL REDUCE INDOOR FORMALDEHYDE LEVELS.

*Weyerhaeuser Company*

Ventilation is important in maintaining a comfortable environment and we direct your attention to the discussion of ventilation contained in your Owner's Manual.

## **SAFETY REGULATIONS REGARDING LP GAS SYSTEMS AND LP GAS APPLIANCES**

The manufacturer of this recreational vehicle is required to furnish the following consumer information as provided by the National Fire Protection Association and the American National Standards Institute. The information and warnings found here may also be found in other chapters of this Owner's Manual. Please see chapters titled "LP GAS SYSTEM" and "APPLIANCES" for other safety and operating information.

### **WARNING**

LP GAS CONTAINERS SHALL NOT BE PLACED OR STORED INSIDE THE VEHICLE. LP GAS CONTAINERS ARE EQUIPPED WITH SAFETY DEVICES WHICH RELIEVE EXCESSIVE PRESSURE BY DISCHARGING GAS TO THE ATMOSPHERE.

### **WARNING**

IT IS NOT SAFE TO USE COOKING APPLIANCES FOR COMFORT HEATING. COOKING APPLIANCES NEED FRESH AIR FOR SAFE OPERATION. BEFORE OPERATION:

1. OPEN OVERHEAD VENT OR TURN ON EXHAUST FAN, AND
2. OPEN WINDOW

THIS WARNING LABEL HAS BEEN LOCATED IN THE COOKING AREA TO REMIND YOU TO PROVIDE AN ADEQUATE SUPPLY OF FRESH AIR FOR COMBUSTION. UNLIKE HOMES, THE AMOUNT OF OXYGEN SUPPLY IS LIMITED DUE TO THE SIZE OF THE RECREATIONAL VEHICLE, AND PROPER VENTILATION WHEN USING THE COOKING APPLIANCE(S) WILL AVOID DANGERS OF ASPHYXIATION. IT IS ESPECIALLY IMPORTANT THAT COOKING APPLIANCES NOT BE USED FOR COMFORT HEATING AS THE DANGER OF ASPHYXIATION IS GREATER WHEN THE APPLIANCE IS USED FOR LONG PERIODS OF TIME.

### **WARNING**

PORTABLE FUEL-BURNING EQUIPMENT, INCLUDING WOOD AND CHARCOAL GRILLS AND STOVES, SHALL NOT BE USED INSIDE THIS RECREATIONAL VEHICLE. THE USE OF THIS EQUIPMENT INSIDE THE RECREATIONAL VEHICLE MAY CAUSE FIRES OR ASPHYXIATION.

### **WARNING**

DO NOT BRING OR STORE LP GAS CONTAINERS, GASOLINE, OR OTHER FLAMMABLE LIQUIDS INSIDE THE VEHICLE BECAUSE A FIRE OR EXPLOSION MAY RESULT.

A warning label has been located near the LP gas container. This label reads: DO NOT FILL CONTAINER(S) TO MORE THAN 80 PERCENT OF CAPACITY.

Overfilling the LP gas container can result in uncontrolled gas flow which can cause fire or explosion. A properly filled container will contain approximately 80 percent of its volume as liquid LP gas.

The following label has been placed in the vehicle near the range:

#### **IF YOU SMELL GAS:**

1. Extinguish any open flames, pilot lights and all smoking materials.
2. Do not touch electrical switches.
3. Shut off the gas supply at the tank valve(s) or gas supply connection.
4. Open doors and other ventilating openings.
5. Leave the area until odor clears.
6. Have the gas system checked and leakage source corrected before using again.

LP gas regulators must always be installed with the diaphragm vent facing downward. Regulators that are not in compartments have been equipped with a protective cover. Make sure that regulator vent faces downward and the cover is kept in place to minimize vent blockage which could result in excessive gas pressure causing fire or explosion.

This page intentionally left blank.

# TABLE OF CONTENTS

---

<b>1</b>	<b>INTRODUCTION</b>	
	Warranties .....	1-3
	Reporting Safety Defects .....	1-5
	Owner's Information Package .....	1-5
	Chassis and Vehicle Identification .....	1-6
	Suspension Alignment and Tire Balance .....	1-7
	After Market Steering Aid Devices .....	1-8
	Warnings, Terms and Concepts for	
	Safe Operation of Your Motor Home .....	1-8
	<i>Vehicle Crush</i> .....	1-8
	<i>Vehicle Handling</i> .....	1-9
	<i>Vehicle Response</i> .....	1-9
	<i>Vehicle Towing</i> .....	1-9
	<i>Alterations to Your Motor Home</i> .....	1-10
	<i>Maintenance</i> .....	1-11
	<i>Warning Devices</i> .....	1-11
<b>2</b>	<b>AIR BRAKE SYSTEM</b>	
	How Does ABS Work? .....	2-1
	ABS Warning Lamp .....	2-1
	System Components .....	2-2
	<i>Air Compressor</i> .....	2-2
	<i>Air Tanks</i> .....	2-2
	<i>Air Dryer</i> .....	2-3
	<i>The Brake Pedal</i> .....	2-3
	<i>Spring Brakes</i> .....	2-3
	<i>Air Gauges</i> .....	2-3
	<i>Parking Brake</i> .....	2-4
	Using Air Brakes .....	2-5
	<i>Stopping Distance</i> .....	2-5
	<i>Braking On Downgrades</i> .....	2-6
<b>3</b>	<b>AIR CONDITIONERS</b>	
<b>4</b>	<b>AIR SUSPENSION SYSTEM</b>	
<b>5</b>	<b>APPLIANCES</b>	

# TABLE OF CONTENTS

---

<b>6</b>	<b>SEMI-AUTOMATIC LEVELING SYSTEM</b>	
	Leveling Procedure .....	6-2
	Emergency Retracting Procedure .....	6-4
	Oil Tank Fill Procedure .....	6-5
<b>7</b>	<b>CARBON MONOXIDE SAFETY PRECAUTIONS</b>	
	Carbon Monoxide Detector .....	7-2
<b>8</b>	<b>DRIVER'S CONTROLS</b>	
	Instrument Panel .....	8-1
	Shift Selector (Side-Pod) .....	8-2
	Engine Temperature Gauges .....	8-2
	Cruise Control Operation .....	8-3
<b>9</b>	<b>DRIVING AND VEHICLE CONTROL</b>	
	Engine and Transmission .....	9-1
	Driving On Downgrades .....	9-3
	Using The Engine To Slow The Motor Home .....	9-3
	Gear Preselection .....	9-3
	Exhaust Brake .....	9-4
	Mirrors and Parking .....	9-4
	General Driving Tips .....	9-5
<b>10</b>	<b>ELECTRICAL CHASSIS SYSTEMS</b>	
	Auxiliary Start System .....	10-2
<b>11</b>	<b>ELECTRICAL HOUSE SYSTEMS — 12- AND 120-VOLT</b>	
	12-Volt System .....	11-1
	Battery Disconnect .....	11-1
	Battery Inspection and Care .....	11-2
	Battery Charging .....	11-3
	Solar Panel .....	11-4
	Selecting A Replacement Battery .....	11-4
	120-Volt System .....	11-4
	Power Cord Hook-Up .....	11-5
	Power Converter .....	11-6
	Power Inverter .....	11-6
	Ground Fault Interrupter .....	11-7
	House Fuses and Circuit Breakers .....	11-8



# TABLE OF CONTENTS

TOC  
Page 3 of 7

---

<b>12</b>	<b>ELECTRICAL SYSTEM WIRING</b>	
<b>13</b>	<b>EMERGENCY TOWING</b>	
<b>14</b>	<b>ENGINE ACCESS</b>	
<b>15</b>	<b>ENGINE OPERATION</b>	
	Normal Starting Procedure .....	15-1
	Normal Shut-Down Procedure .....	15-3
<b>16</b>	<b>ENTERTAINMENT EQUIPMENT</b>	
	Video Cassette Recorder .....	16-1
	TV Antenna .....	16-1
	TV Ghosts and FM Flutter .....	16-2
	Front TV Power Lift .....	16-3
	Digital Satellite System (Optional) .....	16-3
<b>17</b>	<b>ENTRY STEP</b>	
	Pneumatic Stepwell Cover .....	17-2
	<i>Stepwell Cover Operation</i> .....	17-2
<b>18</b>	<b>EXHAUST SYSTEM HEAT</b>	
<b>19</b>	<b>EXTERIOR MAINTENANCE</b>	
	Exterior Finish .....	19-1
	Stains .....	19-3
	Windows, Doors, Vents and Locks .....	19-3
	Fiberglass Roof System .....	19-3
	<i>Care</i> .....	19-4
	Sealant Renewal .....	19-4
	Door, Window, Roof Component and Molding Rescaling .....	19-4
	Stainless Steel Bumpers .....	19-5
	Aluminum Wheels .....	19-6
	Body Undercoating .....	19-6
	Maintenance Chart .....	19-7
<b>20</b>	<b>FIRE SAFETY</b>	
	Fire Safety Precautions .....	20-1
	Smoke Detector .....	20-3

# TABLE OF CONTENTS

---

---

<b>21</b>	<b>FLOOR PLANS</b>	
<b>22</b>	<b>FRESH WATER SYSTEM</b>	
	Connecting Your Motor Home to City Water .....	22-1
	Filling the Fresh Water Tank on Models 40VS, 40DS, 37RS .....	22-3
	Gravity Fill on Model 37RS .....	22-4
	Sanitizing the Fresh Water System .....	22-4
	The Water Pump .....	22-9
	Water Filter .....	22-9
	Troubleshooting the Fresh Water System .....	22-10
	Leaks .....	22-10
	Exterior Shower .....	22-10
	Water Filter System .....	22-11
<b>23</b>	<b>FUEL SYSTEM</b>	
	Fuel Fill .....	23-1
	Fuel Recommendations .....	23-2
<b>24</b>	<b>FURNACE(S)</b>	
	Furnace Filter Replacement .....	24-1
<b>25</b>	<b>GENERATOR</b>	
	Generator Fuel Supply .....	25-1
	Generator Operation .....	25-1
	Generator Operating Safety Precautions .....	25-2
	Generator Cooling System .....	25-4
	Generator Maintenance .....	25-4
<b>26</b>	<b>INTERIOR AND FURNISHINGS</b>	
	Effects of Long-Term Occupancy .....	26-1
	Ventilation and Controlling Condensation .....	26-2
	<i>Ventilate with Outside Air</i> .....	26-2
	<i>Reduce Moisture Released Inside the Motor Home</i> .....	26-2
	<i>Ventilate Closets and Cabinets</i> .....	26-2
	<i>Install a Dehumidifier Appliance</i> .....	26-3
	Attaching Accessories to Your Motor Home .....	26-3
	Dinette Conversion .....	26-3
	Sofa/Lounge Conversion .....	26-4
	Folding Doors/Privacy Curtain Dividers .....	26-4

# TABLE OF CONTENTS

---

---

	Interior Lighting .....	26-4
	Overhead Vents .....	26-5
	Folding Chairs .....	26-5
	Sun Visors .....	26-5
	Mini-Blinds .....	26-6
	Day/Night Shades .....	26-6
<b>27</b>	<b>INTERIOR MAINTENANCE</b>	
	Upholstery and Drapes .....	27-1
	Counter Tops .....	27-1
	<i>Corian® Top-Care</i> .....	27-1
	Walls and Ceiling Panels .....	27-1
	Fiberglass Bathtub and Shower Stall .....	27-2
	Floors and Carpeting .....	27-2
	Tile Care .....	27-2
<b>28</b>	<b>LP GAS SYSTEM</b>	
	LP Gas Safety Precautions .....	28-2
	System Components .....	28-4
	<i>Hoses</i> .....	28-4
	<i>LP Gas Regulator</i> .....	28-5
	Using LP Gas At Low Temperatures .....	28-5
	Filling LP Gas Tanks .....	28-7
	LP Gas System Leak Checks .....	28-8
	LP Leak Detector .....	28-9
	Lighting LP Gas Appliances .....	28-10
<b>29</b>	<b>MAINTENANCE CHART</b>	
<b>30</b>	<b>MONITOR PANEL</b>	
	Fluid Monitor Panel .....	30-1
	Link 1000 Instrumentation and Control Panel .....	30-2
<b>31</b>	<b>MOTOR HOME LOADING</b>	
	Responsibility For Proper Loading .....	31-1
	Some Definitions First .....	31-1
	Carrying Capacity Label .....	31-3
	Towing a Vehicle or Trailer .....	31-4
	<i>Carrying Capacity and Loading Distribution</i> .....	31-6

# TABLE OF CONTENTS

---

	<i>How To Weigh Your Loaded Motor Home Without a Trailer or Towed Load</i> .....	31-7
	<i>How To Weigh Your Loaded Motor Home With a Trailer or Other Towed Load</i> .....	31-9
	<i>Loading Tips</i> .....	31-10
<b>32</b>	<b>RANGE AND RANGE HOOD</b>	
<b>33</b>	<b>REAR VIEW AUDIO/VIDEO MONITOR</b>	
<b>34</b>	<b>REFRIGERATOR</b>	
	Two-Way Automatic Refrigerator .....	34-1
<b>35</b>	<b>SEATS AND SEAT BELTS</b>	
	Combination Lap and Shoulder Belts .....	35-2
	Safety Belt Maintenance .....	35-3
	Safety Restraints for Children .....	35-3
	Safety Belts for Children .....	35-3
	Safety Seats for Children .....	35-4
<b>36</b>	<b>SERVICE</b>	
	Suggestions for Obtaining Service for Your Motor Home .....	36-2
<b>37</b>	<b>STORAGE</b>	
	Exterior Compartments .....	37-1
	Interior Storage .....	37-2
<b>38</b>	<b>STORING THE MOTOR HOME</b>	
	Storage Checklists .....	38-1
	Short-Term Storage .....	38-1
	Long-Term Storage .....	38-3
	Reactivating the Motor Home After Storage .....	38-4
<b>39</b>	<b>TIRES</b>	
	Tire Inflation .....	39-1
	Tire Replacement .....	39-2
	If You Get a Flat Tire .....	39-2
	Changing a Flat Tire .....	39-3
<b>40</b>	<b>TOWING A VEHICLE</b>	
	Towed Vehicle Wiring .....	40-3

# TABLE OF CONTENTS

---

<b>41</b>	<b>TRANSMISSION OPERATION</b>	
	Allison Transmission .....	41-1
	<i>Starting the Vehicle</i> .....	41-1
	<i>Digital Display</i> .....	41-1
	<i>Operation of the Shift Selector</i> .....	41-1
	<i>Mode Button</i> .....	41-2
	<i>Check Transmission Light</i> .....	41-2
	<i>Service Indicator</i> .....	41-3
	<i>Diagnostic Codes</i> .....	41-3
<b>42</b>	<b>WASTE WATER SYSTEM</b>	
	Toilet.....	42-1
	Draining The Holding Tanks .....	42-1
	<i>San-T-Flush®</i> System Operation .....	42-3
	Holding Tank Care .....	42-4
<b>43</b>	<b>WATER HEATER</b>	
	LP/120 -Volt Water Heater .....	43-1
	Water Heater Bypass Valve.....	43-2
<b>44</b>	<b>WINDOWS</b>	
	Dual Pane Windows .....	44-1
	Emergency Exit Window .....	44-1
	Power Windows .....	44-1
<b>45</b>	<b>WINTERIZATION</b>	
	Water System Winterizing .....	45-1
<b>46</b>	<b>SPECIFICATIONS</b>	
	Lamps and Bulbs .....	46-1
	Fuses and Circuit Breakers .....	46-2
	<i>120-Volt Circuits</i> .....	46-2
	<i>12-Volt Circuits</i> .....	46-2
	Tank Capacities.....	46-4
	Exterior Sealant Recommendations.....	46-4
	Engine/Transmission Replacement Filters .....	46-4
	Generator Filters .....	46-4
<b>47</b>	<b>SLIDE-OUT ROOMS</b>	

**This page intentionally left blank.**

---

Welcome to the RV life-style and the growing family of motor home owners. We sincerely thank you for choosing a Fleetwood motor home!

Your motor home has been designed to provide you with years of carefree, pleasant traveling and vacationing. It conforms with, or exceeds, applicable *American National Standards Institute (ANSI)*, *National Fire Protection Association (NFPA)*, *Canadian Standards Association (CSA)* (units built for Canada only), *Federal Motor Vehicle Safety Standards (FMVSS)* and *Environmental Protection Agency (EPA)* and *California Air Resources Board (CARB)* regulations. These standards and regulations establish the plumbing, heating, electrical and other requirements for safety. The seal attached just outside the entry door indicates compliance with *ANSI* or *SCA* standards.

Like all finely crafted equipment, your motor home will require care and regular maintenance in order to deliver maximum value and performance. The dealer will give you basic operating and maintenance instructions; **however, supplement this by reading all instructional material furnished with the motor home in the Owner's Information Package and Chassis Operator's/Owner's Guide/Manual.** This information outlines important areas of maintenance and provides a maintenance schedule for you to follow for safe, trouble free service from your motor home. Study these instructions carefully before you operate the motor home for the first time. A good working knowledge of your motor home and how to care for it will help you enjoy many miles and years of recreational living. *Failure to follow the operating and maintenance instructions and requirements could result in personal injury, damage to the motor home and will cause a loss of warranty coverage.*

*NOTE: This manual describes many features of your motor home and includes instructions for its safe use. This manual, including photographs and illustrations, is of a general nature only. Some equipment and features described or shown in this manual may be optional. Because of the continuous program of product improvement conducted by Fleetwood, it is possible that recent product changes may not be included. The instructions included in this manual are intended as a guide, and in no way extend the responsibilities of the manufacturing subsidiary, parent company or affiliates beyond the standard written warranty as presented in this manual.*

# INTRODUCTION

---

*In this manual, statements preceded by the following words are of special significance:*

**“WARNING”** means that there is the possibility of personal injury to yourself and others.

**“CAUTION”** means that there is the possibility of damage to the vehicle.

**“NOTE”** indicates points of particular interest for more efficient and convenient operation.

*Please pay close attention to these statements while you read this manual.*

*NOTE: This product is designed for recreational use and short term occupancy only. It is not designed or intended to be used as permanent housing. Use of this product for long term or permanent occupancy may lead to premature deterioration of interior finishes, fabrics, carpeting, drapes, and appliances and fixtures. Damage or deterioration due to long term occupancy is not considered normal, and will under the terms of the warranty constitute misuse, abuse, or neglect, thereby reducing your warranty protection. Before considering this motor home for long term occupancy, consult the relevant sections in this manual.*

*If you have any questions regarding operation, maintenance, or service, please contact your dealer immediately. Your dealer's Service or Sales Department will handle any normal problems which might occur.*



---

## **WARRANTIES**

Your motor home is covered by one of the most comprehensive warranty programs in the RV industry. Please refer to the warranty in the front of this manual. It explains your rights and obligations, as well as the rights and obligations of the dealer and manufacturer. Please read this section carefully. You will be better informed in case you have a warranty-related problem, and your dealer will be better able to get you on the road again. If you have any questions about the warranty or what it does or does not cover, please contact your dealer.

The materials in your **Owner's Information Package** contain warranty information and operating and maintenance instructions for the various appliances and components in your motor home. Warranty registration cards for these items should be filled out and mailed as soon as possible after you take delivery of your motor home. If you do not have operating instructions for a particular appliance, contact your dealer.

You will automatically receive an **Ownercare Card** approximately 3-4 weeks after delivery of your new motor home. This card is imprinted with your name, the motor home Fleetwood Identification Number (F.I.N.) and the manufacturing subsidiary location. If your motor home ever needs warranty service, present this card to the dealer, or have it available when contacting a Fleetwood Service Center.

The motor home has been thoroughly inspected before shipment. Your dealer is responsible for performing a complete predelivery inspection of the chassis and all motor home components as specified in the predelivery checklists supplied by the motor home and chassis manufacturers. **You should receive a copy of these completed checklists from your dealer when your motor home is delivered to you.**

As a part of the predelivery inspection procedure, the dealer is responsible for road testing the motor home, noting and correcting any front end alignment problems before delivery. *Fleetwood and its subsidiaries will not be responsible for front end alignment after this predelivery inspection is done.* Front end alignments are performed on each vehicle as a final production procedure.

# INTRODUCTION

---

You should return your motor home to the selling dealer for warranty service. If this is not possible, you may contact any other authorized Fleetwood motor home dealer. The service department at the manufacturing plant can help you find a dealer in your area.

If you have a warranty or service concern about the chassis portion of your vehicle please be aware that you may go directly to an authorized chassis dealer for service. This may save you time and effort as the chassis warranty is administered by the chassis manufacturer. Consult your area phone directory for an authorized dealer and make arrangements with their service department. If you are unsure if the concern is chassis related, feel free to contact your Fleetwood dealer to assist you.

If, for some reason, a problem is not handled to your satisfaction:

1. Discuss any warranty-related problems directly with the manager and/or owner of the dealership, giving them an opportunity to help the service department resolve the matter for you.
2. If a problem arises that has not been resolved to your satisfaction by your local dealer, please contact:

**Fleetwood's American Coach Division  
Parts and Service  
1420 West Patterson Street  
Decatur, IN 46733  
Phone (800) 435-7345**

3. We sincerely believe that your dealer and the factory representative will be able to solve any problem which might arise. If their combined efforts are not satisfactory, please send a letter describing the circumstances to:

**Motor Home Consumer Affairs  
Fleetwood Enterprises, Inc.  
P.O. Box 7638  
Riverside, CA 92513-7638**

Please include the brand name and Fleetwood Identification Number (F.I.N.) of your motor home. The F.I.N. is located on the identification tag next to the entry door or on the exterior left front side of the motor-home.

---

There may be times when your motor home will need repairs or parts while you are on the road. If your motor home is repaired by a non-authorized repair facility (non-Fleetwood dealer), be sure to save receipts and especially any parts that are replaced. These parts will usually have to be returned to your dealer before you can be reimbursed for their cost.

## **REPORTING SAFETY DEFECTS**

If you believe that your vehicle has a defect which could cause a crash or could cause injury or death, you should immediately inform the National Highway Traffic Safety Administration (NHTSA) in addition to notifying the Fleetwood Enterprises Consumer Affairs Department.

If NHTSA receives similar complaints, it may open an investigation, and if it finds that a safety defect exists in a group of vehicles, it may order a recall and remedy campaign. NHTSA cannot become involved in individual problems between you, your dealer or Fleetwood's manufacturing subsidiary.

To contact NHTSA, you may either call the Auto Safety Hotline toll-free at 1-800-424-9393 (or 366-0123 in Washington, D.C.) or write to:

**NHTSA**  
**U.S. Department of Transportation**  
**400 Seventh St. SW**  
**Washington, DC 20590.**

You can also obtain other information about motor vehicle safety from the NHTSA Hotline.

## **OWNER'S INFORMATION PACKAGE**

This package contains valuable documents about your motor home and its equipment and systems. Since this Owner's Manual does not cover every possible detail of equipment and options installed on or in your motor home, there are booklets and instructional material in the package that will help you safely operate, maintain and troubleshoot those items.

# INTRODUCTION

---

*Be sure you read all this information and understand the safety and operating instructions included in the package. Additionally, you must follow all maintenance instructions to insure full warranty coverage.*

If you ever decide to sell or trade your motor home, be sure the new owner gets all the material in this package.

## **CHASSIS AND VEHICLE IDENTIFICATION**

Several numbers are used to identify the vehicle and components used on the vehicle.

The **V.I.N.** or *Vehicle Identification Number* is the identification of the completed vehicle and is the number of the vehicle registration. The V.I.N. is found on the Federal certification tag attached to the interior left sidewall of the motor home driver compartment. Refer to this information when ordering parts from the chassis manufacturer or chassis dealer service center.

The **F.I.N.** or *Fleetwood Identification Number* is located on the tag just outside the main entry door or on the outside left front side of the motor home. Use this number when ordering parts through your Fleetwood dealer or Service Center.

(sample)

<b>FEDERAL CERTIFICATION TAG</b>			
MFG BY:	DATE OF MFR		
INCOMPLETE VEHICLE MFG. BY:	DATE OF INC. VEH. MFR		
GVWR:	KGS (	LBS)	
GAWR FRONT:	KGS (	LBS)	
	WITH:	RIMS	
	TIRES AT:	KPA COLD SINGLE	
	(	PSI)	
GAWR INTERMEDIATE:	KGS (	LBS)	
	WITH:	RIMS	
	TIRES AT:	KPA COLD DUAL	
	(	PSI)	
GAWR REAR:	KGS (	LBS)	
	WITH:	RIMS	
	TIRES AT:	KPA COLD SINGLE	
	(	PSI)	
GAWR COMBINED INTERMEDIATE AND REAR:	KGS (	LBS)	
This vehicle conforms to all applicable U.S. Federal Motor Vehicle Safety Standards in effect on:			
V.I.N.			
TYPE VEHICLE: MULTI-PURPOSE PASSENGER VEHICLE			
The tires on this unit may be different from those shown above. Check tire sidewalls for maximum inflation pressure.			
Replacement tires must be rated no less than the axle capacity (GAWR).			
W15-0002			

*Located in the motor home driver compartment.*

V.I.N. (Vehicle Identification No.)

**VEHICLE IDENTIFICATION NUMBER**

**BAR CODE**

*This tag is located on the left top of the instrument panel.*

(sample)

**FLEETWOOD  
MOTOR HOMES**

OF INC.

PLAN APPROVAL NO.

F.I.N.

MFR. ID NO. MODEL

DATE OF MFR MO: YR

*Located on the left of the main entry door or on exterior left front side of the motor home.*

F.I.N. (Fleetwood Identification No.)

## **SUSPENSION ALIGNMENT AND TIRE BALANCE**

The front suspension and steering system of this vehicle was accurately aligned at the factory before delivery to the dealership. However, after you have fully loaded the vehicle according to your personal needs, have the alignment checked and adjusted, if necessary. To help prevent uneven tire wear, check the front-end alignment periodically.

*Please note that front-end alignment after retail delivery is the owner's responsibility and is not covered under the warranty.*

- Excessive or abnormal tire wear may indicate worn or misaligned suspension or steering components, unbalanced tire(s) or some other tire/suspension problem.

# INTRODUCTION

---

Alignment can be affected by worn steering/suspension parts or road hazards such as hitting a curb, pothole, railroad track, etc. Improper alignment can cause tires to roll at an angle and wear unevenly. It may also cause the vehicle to “pull” to the right or left.

Out-of-balance tires will not roll smoothly and will cause annoying vibrations and uneven tread wear such as cupping or flat spots. If you see uneven tire tread wear or if the vehicle ride comfort decreases, the tires may need to be balanced.

See the **Chassis Operator’s/Owner’s Guide/Manual** for more information.

## **AFTER-MARKET STEERING AID DEVICES**

Fleetwood does not sanction or condone the installation of any steering aid device that is not approved by our chassis manufacturer’s. Any add-on device of this type will likely void the chassis manufacturer’s warranty on the item or items affected.

Any after-market steering aid device proposed for installation must be approved by *Fleetwood Motor Home Product Engineering* before considering it for any after-market installation on your motor home.

## **WARNINGS, TERMS AND CONCEPTS FOR SAFE OPERATION OF YOUR MOTOR HOME**

### **Vehicle Crash**

Like any other vehicle you may drive, your motor home can be involved in a vehicle crash, including a rollover. The motor home will be damaged and you and others can be injured or killed. Drive defensively at all times. **DO NOT** drive if you are tired, have been drinking alcoholic beverages, are under the influence of any controlled substance, or are taking any medication or drugs that may impair your sight, hearing, judgment or coordination. Pull off the road and park in a safe area until you can drive safely.

---

## ***Vehicle Handling***

Your motor home is longer, wider and higher than a typical car or truck you may be accustomed to driving. Keep this in mind as you become familiar with driving your motor home. New motor home owners should take special care to learn the driving and handling characteristics of your vehicle in safe and familiar surroundings. The distribution of the weight of your motor home is designed so it will handle safely while being driven.

- *When loading the motor home, balance the load front-to-rear and side-to-side.*
- *Load and secure heavier items lower in the storage areas than lighter items.*

If you fail to properly load your belongings and supplies, you will defeat the load distribution design of the motor home, possibly leading to handling problems and a vehicle crash.

## ***Vehicle Response***

When you, the driver, accelerate, brake or steer the motor home, it responds to these inputs. If you are faced with an emergency while driving, the way you respond to the emergency and the way the motor home responds becomes more critical. If you load, alter or maintain your motor home improperly, it will not respond as it did when you first received it in an unloaded condition. *Improper loading, alteration, maintenance and improper driver responses to emergency conditions can lead to handling problems and vehicle crashes.*

## ***Vehicle Towing***

Your motor home can be equipped with a hitch designed to allow you to tow vehicles or other loads behind your motor home. The maximum amount of weight your motor home can pull or stop is determined by the manufacturer of the chassis on which your motor home is built. Check the **Chassis Operator's/Owner's Guide/Manual** provided by the motor home chassis manufacturer for the limits on the weight you can tow.

# INTRODUCTION

---

If the **Chassis Operator's/Owner's Guide/Manual** does not provide information on towing weight limits, do not tow a load of more than 1000 pounds unless the towed unit has a properly installed and operating supplemental brake control system that operates with the brakes on your motor home.

- *You may be able to increase the weight of any towed load by properly installing on the towed load a supplemental brake control system that operates with your motor home's braking system. Even with additional brakes, you cannot tow more than the GTW or GCWR for the chassis under your motor home. Again, check the Chassis Operator's/Owner's Guide/Manual.*
- *You CANNOT increase the towed weight limit by changing the size of your hitch.*
- *Properly load what you tow to avoid a vehicle crash.*
- *Do not attempt to tow something that is too heavy for your chassis.*
- *When driving in mountainous areas, look for and obey highway signs concerning grades and curves. Your driving experience when pulling and stopping a towed unit on mountain roads will be very different from what you experience on level ground.*
- *State laws in the United States and provincial laws in Canada are different concerning towing requirements and limits. Check the laws in the areas where you anticipate traveling.*

## **Alterations to Your Motor Home**

Many motor home owners like to add a personal touch to their motor home. But there is a difference between changing how your motor home looks versus how it handles or responds to driver inputs. If you expect to make any type of alteration to your motor home, consult a professional who understands the correct way to do the alteration and how the alteration will change or affect the



stability, handling, vehicle response, and overall performance and safety of your motor home. *An improper alteration that affects vehicle handling or response can cause a vehicle crash, and any improper alteration to the electrical or LP gas systems can cause a fire and can endanger your motor home and its occupants.* Fleetwood and your chassis manufacturer stand behind the motor home as delivered - **NOT** as altered by someone else.

## ***Maintenance***

It is your responsibility to properly maintain your motor home. Consult your Fleetwood and **Chassis Operator's/Owner's Guide/Manual** for service information. See an authorized Fleetwood dealer to have your motor home serviced or repaired. You, or an experienced professional, should check all fluid levels and change fluids and filters when needed. Tire condition and proper inflation pressure is critical to safe operation. Keep your vehicle properly maintained to help avoid a vehicle crash.

## ***Warning Devices***

Your motor home is equipped with warning devices. Check them before a trip for proper operation. A disabled warning device cannot warn you or your occupants of a life-threatening danger. Keep them working and respond to them quickly.

This page intentionally left blank.

---

## **HOW ABS WORKS**

Your motor home is equipped with ABS anti-lock air brakes. ABS is an electronic system that monitors and controls wheel speed during braking. The system works with standard air brake systems.

ABS monitors wheel speeds at all times and controls braking during wheel lock situations. The system improves vehicle stability and control by reducing wheel lock during braking.

The ECU (electronic control unit) receives and processes signals from the wheel speed sensors. When the ECU detects a wheel lockup, the unit activates the appropriate modular valve, and air pressure is controlled.

In the event of a malfunction in the system, the ABS in the affected wheel(s) is disabled; that wheel still has normal brakes. The other wheels keep the ABS function.

The ABS warning lamp lets drivers know the status of the system. This lamp is also used to display blink code diagnostics.

## **ABS WARNING LAMP**

The ABS warning lamp works as follows:

**NORMAL OPERATION**, with the ignition key ON, ABS lamp comes on at ignition momentarily for a bulb check, then goes out. System is O.K.

**AFTER SERVICING ABS SYSTEM**, with the ignition key ON, ABS lamp does not go out at ignition. When vehicle is driven at speeds above 4 mph (6km/h), lamp goes out. System is O.K.

**EXISTING FAULT**, ABS lamp does not go out at ignition. Lamp does not go out at speeds above 4 mph (6km/h) - a fault exists in the ABS system.

# AIR BRAKE SYSTEM

---

## Caution

In order to ensure that system performance and reliability is preserved, all service intervals and procedures must be followed when carrying out maintenance and repairs. Only original equipment approved service should be used.

For more information about the ABS anti-lock brake system, please refer to the **Chassis Operator's/Owner's Guide/Manual**.

Your motor home is equipped with ABS anti-lock air brakes. Air brakes are more sensitive than hydraulic brakes. Practice stopping in a safe, unobstructed area until you get the feel of the brake pedal.

The front air pressure gauge on the instrument panel indicates front brake system air pressure. The rear air pressure gauge indicates rear brake system air pressure. Please note that the vehicle will not move until air pressure is sufficient to release the brake safety springs. The gauges must indicate a minimum of 60 psi on the gauges before the motor home can be moved. A dash indicator will light and a buzzer will sound until the proper operating pressure is reached.

## **SYSTEM COMPONENTS**

### ***Air Compressor***

The air compressor pumps air into the air storage tanks. It is gear driven by the motor home engine.

### ***Air Tanks***

These tanks hold compressed air for the brake system. They will hold enough air to allow the brakes to be used several times even if the compressor stops working. Entrapped liquid must be drained from the air tanks at frequent intervals. Consult the **Chassis Operator's/Owner's Guide/Manual** for additional information.

## ***Air Dryer***

Compressed air usually has some water and compressor oil in it. This compressed air is cycled through a dryer to remove air system contaminants. Consult the **Chassis Operator's/Owner's Guide/Manual** for additional information.

## ***The Brake Pedal***

The harder you push down on the pedal, the more air pressure is applied to the brakes. When you let up on the pedal, some of the brake pressure is released. You will hear the air escape when you let up on the pedal.

As this air is released, the compressor must build the pressure back up. Pressing and releasing the pedal repeatedly can let air out of the system faster than the compressor can restore it. If the pressure gets too low, the service brakes will not function properly, and the spring brakes will be applied automatically.

When you push down on the pedal, you will feel both a spring pressure and the air pressure back against your foot. With practice, you will know how to judge the force necessary to stop your motor home.

## ***Spring Brakes***

The spring brakes are applied automatically whenever there is a loss of air pressure in the braking system, or when the parking brake is applied.

## ***Air Gauges***

The pressure gauges on the instrument panel tells you how much air pressure is in the tanks, and whether the system will operate. An audible buzzer and dash indicator light warns you if air pressure is insufficient for proper brake operation.

## AIR BRAKE SYSTEM

---

### CAUTION

If the low pressure buzzer or light ever comes on while the motor home is in motion, exercise extreme caution. Stop and park the motor home as soon and as safely as possible by down-shifting the transmission and/or by activating the exhaust brake. Apply the parking brake as soon as the vehicle is motionless. The spring brake system will apply the brakes as pressure drops.

### WARNING

If a rapid loss of air pressure occurs in the braking system, the spring brakes will be applied suddenly. This may cause loss of traction and vehicle control. Refer to the Chassis Operator's/Owner's Guide/Manual for further information on the functioning of the brake system.

### *Parking Brake*

### WARNING

Your motor home transmission does not have a PARK position. Place the transmission in neutral (N) and set the parking brake when you park the motor home.

The parking brake control is a yellow, diamond-shaped, push-pull control knob. **Pull the knob out to set the brake, and push in to release.**

Any time you park, use the parking brake, except:

*– if the brakes are very hot. Brake system components can be damaged by excessive heat.*

*– In freezing temperatures, if the brakes are very wet. The brake shoes on your motor home cover a large surface area. If they become very wet and freeze to the brake drums, the motor home will not be able to move until they thaw. If the brakes freeze, DO NOT try to force the motor home to move. Brake system components could be damaged.*

If necessary, use wheel chocks to hold the vehicle. Let hot brakes cool before using the parking brake. If the brakes are wet, use the brakes lightly while driving in a low gear to heat and dry them.

## WARNING

Never leave your motor home unattended without setting the parking brake.

## USING AIR BRAKES

For normal stops, push the brake pedal down until the vehicle comes to a smooth stop.

In emergencies, brake so that you can steer and keep the motor home under control.

## Stopping Distance

With air brakes there is an added delay. After the brake pedal is pressed, the air may take a fraction of a second to activate the brake mechanisms on the wheels. For this reason, the total stopping distance will increase depending on speed. Under good traction and brake conditions, this delay may add up to 35 feet at 55 mph, making the total distance over 300 feet at that speed. Please be aware of this increase in stopping distance, and anticipate your stops with this in mind.

## AIR BRAKE SYSTEM

---

### ***Braking On Downgrades***

Downhill driving puts extra strain on many drivetrain components of your motor home. The brakes are easily overloaded and overheated when used for downhill slowing. Brake fade will occur if the brakes overheat.

When driving down long grades, shift the transmission to a lower gear at the top of the grade. **Rule of thumb:** Use the same lowest gear going down as it took to go up the hill. Crest the hill in the lower gear. Do not exceed the maximum downhill engine speed with exhaust brake ON of 2700 RPM. Monitor your speed.

Please see the **Chassis Operator's/Owner's Guide/Manual** for more information about brake system operation and downhill driving techniques.



The roof-mounted air conditioner(s) can operate only when the motor home is connected to 120-volt AC power from either a public utility or the generator. Be sure to turn the air conditioner circuit breakers ON.

For best performance, park the motor home in the shade and close curtains. Close doors and windows and turn the temperature control knob for desired coolness. Refer to the air conditioner manufacturer's instructions for detailed operating and preventive maintenance requirements. The air conditioners use a large portion of your available electric power.

Some RV parks may experience reduced power (low voltage) on days with high heat or humidity. This condition is commonly called a "brown out". A brown out may cause the air conditioner circuit breaker in the distribution panel to trip. This protects your air conditioner motor from damage and is necessary during low voltage conditions. This breaker tripping is not a fault in your electrical system, but it is a necessary "safety valve."

Either or both air conditioners can be operated if the generator is running, or if the unit is plugged into park power with the 50-amp shore line.

*NOTE: Your motor home is equipped with a ceiling-ducted air conditioning system. For most efficient operation, adjust each vent so that it is completely open. If you change the vent opening to regulate air flow try not to restrict the vent opening to fall below 70% open. Restricting air flow below this opening will affect the efficiency of the air conditioner.*

This page intentionally left blank.

# AIR SUSPENSION SYSTEM

---

Your motor home is equipped with air suspension. When the engine is started the suspension will begin to fill with air, lifting the motor home body 4-6 inches. A buzzer will sound until the air tanks are sufficiently full for proper operation.

Air pressure valves control the motor home ride height. Each wheel maintains a preset distance between the chassis and the wheel. Each air bag (one at each axle) may contain a different air pressure. This pressure is determined automatically by the system to maintain a level chassis, and is continually adjusted as long as the chassis engine is running, or there is sufficient air pressure in the air storage tank.

*The air suspension system is not the same as the Semi-Automatic Leveling System. See "Semi-Automatic Leveling System."*

This page intentionally left blank.

The appliances installed in your motor home are tested by independent laboratories and comply with rigid standards established by these organizations. All appliances are covered by Fleetwood's Ownercare Warranty program. Each appliance is also warranted by its manufacturer.

*NOTE: The individual appliance manuals included in your **Owner's Information Package** contain detailed operating and maintenance instructions. Always refer to the respective manual for the appliance in question.*

## WARNING

The water heater and furnace combustion air exhaust ports may be extremely hot during water heater and furnace operation. **DO NOT TOUCH THESE OUTLETS** or allow any material to come within close proximity of exhaust ports while operating the water heater and/or furnace.

This page intentionally left blank.

# SEMI-AUTOMATIC LEVELING SYSTEM

Controls for the leveling system are located on the instrument panel. A detailed operating and maintenance guide is included in your **Owner's Information Package**. Read all instructions for this system carefully before operating the system.

The leveling system and the chassis air suspension system work together. Please note that when the leveling system is activated, air pressure is released and you may feel a momentary "floating" sensation before the leveling system is fully engaged. This is normal. When the leveling system is retracted, the suspension system will be re-charged with air.

## WARNING

The leveling system is intended solely to level the motor home. **DO NOT USE THE LEVELING SYSTEM AS A JACK. DO NOT ATTEMPT TO LIFT THE MOTOR HOME OFF THE GROUND WITH THE LEVELING SYSTEM for any reason.**

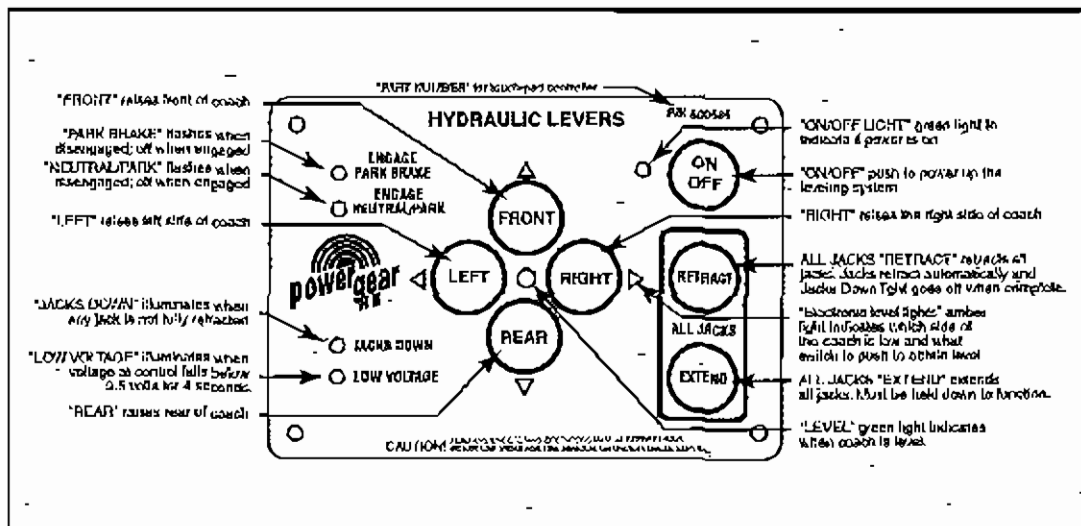

Leveling System Controls

**NOTE:** The leveling system fluid pump and manual override valves are located in the rear curbside engine access area.

# SEMI-AUTOMATIC LEVELING SYSTEM

---

## **LEVELING PROCEDURE**

Before you operate the leveling system, verify the following:

- A. *The engine is running.*
- B. *The automotive batteries are **ON** (check the disconnect switch) and have a minimum charge of 11 volts.*
- C. *The brake system is functioning (at least 90 psi on the air pressure gauge) and the **PARKING BRAKE** is set.*
- D. *The transmission selector is in **NEUTRAL**.*
- E. *The touch-pad leveling system is **ON**.*
- F. *There are no obstructions anywhere under the motor home.*

### **To level the unit:**

1. Press **ON/OFF** switch on control panel. **ON/OFF** light and Electronic Level lights will illuminate.
2. Push and **HOLD** the **ALL JACKS DOWN** switch until the jacks contact the ground.
3. Observe the **FRONT** and **REAR** Electronic Level lights (arrows). Push and **HOLD** the corresponding pad until the pump turns off and leveling action stops.
4. Observe the **LEFT** and **RIGHT** Electronic Level lights (arrows). Push and **HOLD** the corresponding pad until the pump turns off and leveling action stops.
5. Observe the green level indicator light. It should be illuminated, indicating the motor home is level. If not, repeat steps 3, 4 and 5.



# SEMI-AUTOMATIC LEVELING SYSTEM

6. If further adjustments are required, push the appropriate switch to override the system and level the coach as desired.
7. Visually confirm that all jacks are firmly on the ground.

*NOTE: If the grade is too steep for the leveling system to level the motor home, the motor home may have to be moved to a more level location.*

## **To retract the system:**

1. Press **ON/OFF** switch on the touch-pad. The **ON/OFF** light, the green **LEVEL** indicator light (if level) and the **JACKS DOWN** light will illuminate.
2. Momentarily press the **ALL JACKS RETRACT** switch. The jacks will start to retract and return to the fully retracted position automatically.
3. When the **JACKS DOWN** light goes out, push the **ON/OFF** switch on the touch-pad to de-energize the system.
4. Visually confirm that all jacks are retracted.

*NOTE: The **JACKS DOWN** light indicates that one or more jacks are extended, not fully retracted.*

If the touch-pad is left on and inactive for four minutes it will shut off automatically.

# SEMI-AUTOMATIC LEVELING SYSTEM

If leveling controls operation is improper, turn the ignition key off, check the leveling control box fuses located on the ceiling of the 2nd or 3rd curbside storage compartment from the front of the coach. Turn the ignition and touch-pad back on, if problem persist see an authorized dealer or call Power Gear's customer service at 1-800-334-4712.

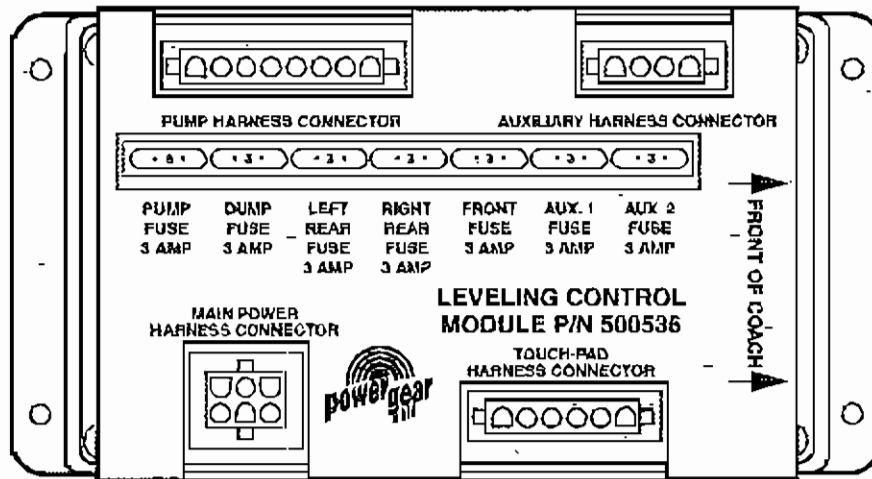

Correct oil level is critical for proper operation. Low hydraulic fluid will sound the touch-pad alarm and flash the jacks down light with the jacks in the fully retracted position. Fill fluid to lip of fill port to eliminate this condition.

## **EMERGENCY RETRACTING PROCEDURE**

### **WARNING**

Do not use this procedure if retraction with the leveling touch-pad controller is possible.

1. Be sure no one is under the motor home.
2. Be sure all obstacles are removed from under the motor home.
3. Turn the ignition **OFF**.
4. Transmission to **NEUTRAL** position.
5. Set **PARKING BRAKE**.
6. Keep all body parts from beneath the motor home.

# SEMI-AUTOMATIC LEVELING SYSTEM

7. To override:

Locate hydraulic pump and valve block. Release the dump valve first, then the leg valve you wish to override by pushing, turning and locking.

F: Front

RR: Roadside

CR: Curbside

8. Return all manual overrides to their original positions.

9. Have the leveling system checked and serviced by an authorized dealer.

## CAUTION

The suspension air bags (if equipped) may not re-inflate after this procedure. Contact your dealer if this happens.

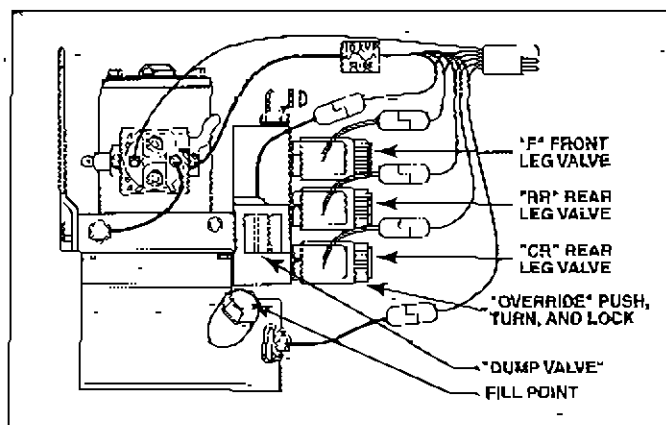

*Motor Pump/Valve Block*

## OIL TANK FILL PROCEDURE:

- 1) Retract all jacks
- 2) Shut off engine
- 3) Remove fill port plug
- 4) Fill with Dextron III transmission fluid until it runs out of the fill port.
- 5) Replace the fill plug

This page intentionally left blank.

# CARBON MONOXIDE SAFETY PRECAUTIONS

---

Carbon monoxide is a colorless, tasteless, odorless gas. It is a by-product of the burning of fossil fuels (gasoline, LP gas, diesel fuel, etc.). The chassis and generator engines, furnaces, water heater, LP gas refrigerator and range in your motor home produce it constantly while they are operating. CARBON MONOXIDE IS DEADLY. Please read and understand the following precautions to protect yourself and others from the effects of carbon monoxide poisoning.

## WARNING

Exhaust gases are deadly. Do not block the tailpipes or exhaust ports, or situate the vehicle in a place where the exhaust gases have any possibility of accumulating either outside, underneath or inside your vehicle or any nearby vehicles. Outside air movements can carry exhaust gases inside the vehicle through windows or other openings remote from the exhaust outlet. Operate engines, carbon monoxide-producing systems or components only when safe dispersion of exhaust gases can be assured. Monitor outside conditions to be sure that exhaust continues to be dispersed safely.

Beware of exhaust gas (carbon monoxide) poisoning symptoms:

*Dizziness*  
*Vomiting*  
*Nausea*  
*Muscular Twitching*  
*Intense Headache*  
*Throbbing in Temples*  
*Weakness and Sleepiness*  
*Inability to Think Coherently*

If you or others experience any of these symptoms, get out into the fresh air immediately. If symptoms persist, seek medical attention. Shut down the unit and do not operate until it has been inspected and repaired.

# CARBON MONOXIDE SAFETY PRECAUTIONS

---

## WARNING

**DO NOT UNDER ANY CIRCUMSTANCES OPERATE ANY ENGINE WHILE SLEEPING.** You would not be able to monitor outside conditions to assure that engine exhaust does not enter the interior, and you would not be alert to exhaust odors or symptoms of carbon monoxide poisoning.

Check the exhaust system frequently for damage. Do not operate an engine with a damaged exhaust system. Do not under any circumstances modify the exhaust system(s) in any way.

## ***CARBON MONOXIDE DETECTOR***

Your motor home is equipped with a carbon monoxide (CO) detector. It is designed to alert you to the presence of CO gas. Test the CO detector after the motor home has been in storage, before each trip, and at least once a week during use. The carbon monoxide detector uses a 9-volt battery.

Refer to the operating instructions included in your **Owner's Information Package**.

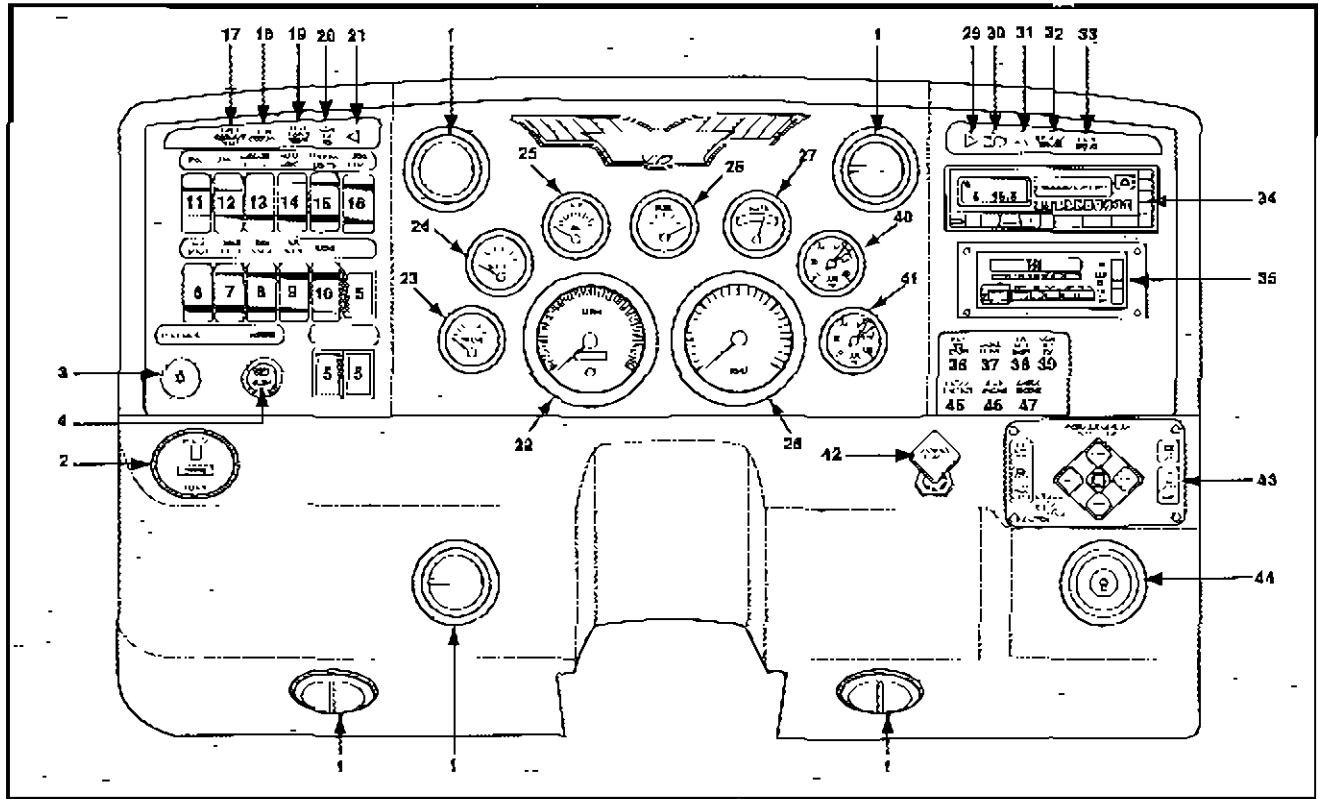

## INSTRUMENT PANEL

- |   |   |
|---|---|
| <ol style="list-style-type: none"> <li>1. Air Vents</li> <li>2. Generator Hour Meter Gauge</li> <li>3. Head Light Switch</li> <li>4. Windshield Wiper/Washer Switch</li> <li>5. Blank</li> <li>6. Auxillary Start (Chassis &amp; Generator Engine)</li> <li>7. Dome Light Switch</li> <li>8. Generator Start Switch</li> <li>9. Air Horn Switch</li> <li>10. Radio Select Switch (Switches power to the radio between the chassis batteries and house batteries.)</li> <li>11. Driver's Fan Switch</li> <li>12. Passenger's Fan Switch</li> <li>13. Luggage Lights Switch</li> <li>14. Hood Lights Switch (Chassis &amp; Generator Engine Areas)</li> <li>15. Docking Lights Switch</li> <li>16. Fog Lights Switch</li> <li>17. Chassis Engine High Coolant Temperature Warning Light</li> <li>18. Chassis Engine Low Coolant Warning Light</li> <li>19. Transmission High Temperature Warning Light</li> <li>20. Chassis Engine Low Oil Pressure Warning Light</li> <li>21. Left Turn Signal Indicator Light</li> <li>22. Speedometer Gauge</li> </ol> | <ol style="list-style-type: none"> <li>23. Transmission Temperature Gauge</li> <li>24. Chassis Engine Coolant Temperature Gauge</li> <li>25. Chassis Engine Oil Pressure Gauge</li> <li>26. Fuel Gauge</li> <li>27. Chassis Engine Voltmeter Gauge</li> <li>28. Chassis Engine Tachometer Gauge</li> <li>29. Right Turn Signal Indicator Light</li> <li>30. High Beam Indicator Light</li> <li>31. ABS Systems Warning Indicator Light</li> <li>32. Exhaust Brake Indicator Light</li> <li>33. Parking Brake Indicator Light</li> <li>34. AM/FM Radio/Cassette/CD Controller</li> <li>35. Cockpit Heater/Air Conditioner Controls</li> <li>36. Chassis Engine Preheat Wait to Start Indicator Light</li> <li>37. Leveling Jacks Down Warning Indicator Light</li> <li>38. Do Not Shift with Check Transmission Warning Indicator Light</li> <li>39. Low Air Pressure Warning Indicator Light</li> <li>40. Front Brake Air Pressure Gauge</li> <li>41. Rear Brake Air Pressure Gauge</li> <li>42. Parking Brake Control Knob</li> <li>43. Leveling Jacks Control Pad</li> <li>44. Chassis Engine Ignition Switch</li> <li>45. Engine Protect Indicator Light</li> <li>46. Stop Engine Indicator Light</li> <li>47. Check Engine Indicator Light</li> </ol> |
|---|---|

## DRIVER'S CONTROLS

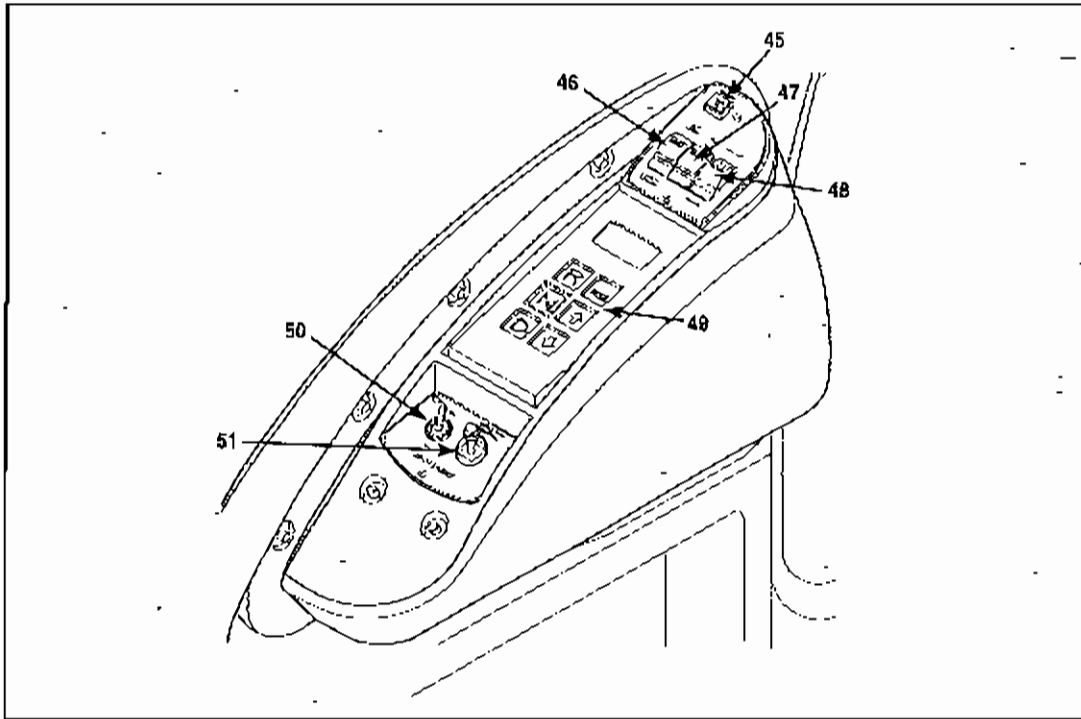

### SHIFT SELECTOR (SIDE-POD)

- |  |   |
|--|---|
| 45. Cruise Control ON/OFF Switch                 | 48. Exhaust Brake Switch                |
| 46. Cruise Control SET-ACCEL/COAST-RESUME Switch | 49. Transmission Shifter                |
| 47. ICC Switch (Intermittent Courtesy Switch)    | 50. Spot Light ON/OFF Switch            |
|  | 51. Spot Light Direction Control Switch |

### ENGINE TEMPERATURE GAUGES

Engine temperature gauges have been calibrated to indicate a midrange reading as the "normal" operating temperature. The reason for this is that many owners perceive 212° F as the boiling point. However, this is not the case in an engine with a pressurized cooling system and a coolant mixture of glycol and water. As a motor home owner, be aware that the gauge is intended to provide a warning of any rapid change in engine coolant temperature from the "normal" reading of the gauge rather than an absolute temperature reading.



---

## **CRUISE CONTROL OPERATION**

*NOTE: The cruise control will not operate at speeds below approximately 30 mph.*

### **To set the cruise control:**

- 1) Press the **ON/OFF** switch to apply power to the unit (ignition switch must be on).
- 2) Accelerate to the desired speed, push up and release the **SET/ACCEL** switch. The vehicle will maintain the speed set when the **SET/ACCEL** switch was released.
- 3) Hold the **SET/ACCEL** switch up to accelerate. When the switch is released, the vehicle will maintain the new speed.

### **The cruise control can be disengaged by any of the following:**

- 1) Press the brake pedal. Press the **COAST/RESUME** switch to resume the previously set speed.
- 2) Push down and hold the **COAST/RESUME** switch. Let up on the **COAST/RESUME** switch to resume the current speed.
- 3) Press the **ON/OFF** switch. If the **ON/OFF** switch is pressed, the **SET/ACCEL** switch must be pressed to set a new speed.

**This page intentionally left blank.**

Driving your motor home will be different from driving your family car or truck. Your motor home is large and heavy. You may have to adjust or learn new driving techniques to safely operate your motor home.

## **ENGINE AND TRANSMISSION**

Your motor home is equipped with a diesel engine. Diesel-equipped vehicles are less responsive than gas-powered vehicles. Acceleration will be slower. Attempts at "jack-rabbit" starts from stops may damage the engine and drive-train components. If you anticipate overtaking and passing other vehicles, remember that your motor home may not achieve the required speed as quickly as you expect.

The engine speed RPM for the engine in your motor home is:

Programmable Idle Speed .....	600 to 875 RPM
Governed Speed .....	2200 RPM
Maximum Downhill Speed with Exhaust Brake ON .....	2700 RPM

### **CAUTION**

**Engine overspeed (engine speed in excess of high idle, no load RPM) can damage the engine.**

### **CAUTION**

**Driving a diesel-powered vehicle is different from driving a gasoline-powered vehicle. Engine over-revving can cause serious internal engine damage.**

See the **Chassis Operator's/Owner's Guide/Manual** for more information on engine operation.

## DRIVING AND VEHICLE CONTROL

---

Your motor home is equipped with an automatic transmission. Please note that this transmission does not provide a PARK position. You **MUST** set the parking brake whenever you park the motor home.

### WARNING

The transmission does not provide a "PARK" position. Place the transmission in neutral (N), and set the parking brake when parking the motor home.

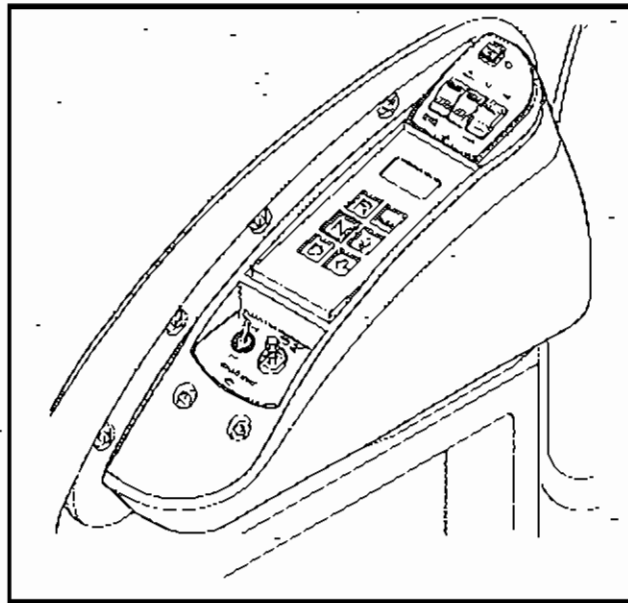

*Shift Selector – Allison MD3060 Transmission*

**NOTE:** For additional transmission operation information see Section 41 of this manual or the "Transmission Section" in the *Chassis Operator's/Owner's Guide/Manual*.

Up- and down-shifting is automatic under most driving conditions. You may manually shift the transmission under marginal or poor traction conditions, up and/or downhill or mountain driving, or under any driving condition to maintain complete vehicle control.

---

## **DRIVING ON DOWNGRADES**

Driving on winding or mountain roads is not difficult if done with reasonable care. Controlling vehicle speed is vital to safe maneuvering in hilly or mountainous areas. Driving slowly will help you keep your motor home under control.

Always operate in the proper transmission range. Downshift on hills to avoid engine and brake overheating or undue engine loads. Downshift when descending grades. Engine compression and friction will help control vehicle speed, and relieve some of the strain on the brakes. **DO NOT EXCEED MAXIMUM ENGINE RPM** for the gear range you are in. Serious component damage could occur. Shift the transmission to a lower gear before starting down the grade. Match speed and gear using the tachometer. Refer to the **Chassis Operator's/Owner's Guide/Manual** for downhill driving technique.

## **USING THE ENGINE TO SLOW THE MOTOR HOME**

To use the engine as a braking force, select the next lower gear. If the motor home is exceeding the maximum RPM for this gear, use the service brakes to slow down. When a lower speed is reached, the transmission Electronic Control Unit (ECU) will automatically downshift the transmission. Engine braking provides good speed control for going down grades. When the motor home is heavily loaded, or the grade is steep, preselection of a lower gear prior to the grade may be desirable.

## **GEAR PRESELECTION**

Gear preselection means selection of a lower gear to match the driving conditions you encounter or expect to encounter. Preselection will give you better control on slick or icy roads and on downgrades. Downshifting to lower gears increases engine braking. The selection of a lower gear often prevents cycling between a gear and the next higher gear on a series of short up-and-down hills.

Mountain driving or desert temperatures can put extreme demands on drive train components. Under extreme heat conditions you may need to turn off the vehicle air conditioner to improve engine and transmission cooling.

**EXHAUST BRAKE**

Your motor home is equipped with an Exhaust Brake. This exhaust brake is an auxiliary braking device for slowing down your vehicle. It reduces the need to use the service brakes, thus reducing wear and tear on the service braking system. When the exhaust brake is activated the brake lights on the vehicle and the dash brake indicator light will illuminate.

The exhaust brake system is controlled by a master ON/OFF switch on the dash side-pod and a throttle switch located in the throttle system. This unit will only function when the master switch is ON and the throttle pedal is at or near idle. On dry road conditions your exhaust brake master switch can be left ON at all times.

Using the exhaust brake on wet or slippery roads—especially on curves—may cause over-braking of the wheels and cause you to skid. It may also increase the stopping distance. See the **Chassis Operator's/Owner's Guide/Manual** for additional information.

**MIRRORS AND PARKING**

Be alert to your vehicle's position in traffic. Use caution when maneuvering to allow for the length and width of the vehicle. Always allow extra room to corner and to change lanes. Your vehicle's rear view mirrors will help you keep aware of your vehicle's position and the position of other vehicles and/or obstructions near your motor home. You must monitor them constantly while you are driving. Become familiar with the operation of the mirrors and learn to use them to view objects and the road beside and behind the motor home.

*NOTE: Objects viewed in convex mirrors appear smaller and farther away than they actually are.*

The rear view mirrors are controlled from a panel located to the driver's left. To adjust the mirrors, select either LEFT or RIGHT mirror and press the appropriate arrow. Activate the mirror heaters by pressing the HEATER position.

## **GENERAL DRIVING TIPS**

Remember that your motor home is heavier than a car, making it less maneuverable and harder to stop. Also, because of its greater side surface area, it is more easily affected by cross winds and/or overtaking traffic. Allow extra distances for passing and stopping, and drive at a moderate speed, particularly in traffic and in gusty wind conditions.

Be aware of the extra height of your motor home. Check for low hanging tree branches or other obstructions whenever you drive or park. Avoid low overhangs when pulling in for service. Always check overhead clearances of overpasses and bridges. *This may be particularly important if you drive with the overhead vents open or if the motor home is equipped with a roof air conditioner, roof rack, CB or TV/radio/satellite antenna.*

Before leaving on a trip, check your route. Some tunnels prohibit motor homes with LP gas systems.

When parking parallel to a curb, be sure to allow for poles or obstructions as the front and rear portions of the motor home swing wider than an automobile. When parking on an incline, turn the front wheels into the curb in the direction of the roll to aid the parking brake. When parking set the parking brake.

## **WARNING**

**Do not park or idle the motor home over combustible materials such as tall grass or dried leaves. Combustible materials may catch fire from the hot exhaust gases, soot or sparks that could escape through corrosion holes or cracks. This is particularly important if the exhaust system has not been properly maintained.**

## DRIVING AND VEHICLE CONTROL

---

Parking or idling should be done only in an area where there are no combustible materials under the vehicle.

If operating, parking or idling your vehicle off-road is unavoidable:

**Be aware that combustible materials could catch fire from the vehicle's hot exhaust system.**

**Avoid driving your vehicle through or over combustible materials such as leaves, grass, vegetation or stubble high enough to touch, catch or collect on its hot exhaust system.**



# ELECTRICAL CHASSIS SYSTEMS

Your motor home is equipped with three electrical systems:

- the chassis 12-volt DC system
- the Fleetwood 12-volt DC house system
- the Fleetwood 120-volt AC house system

They operate together to give you electrical power for many different situations.

These electrical systems comply with all regulations and codes in effect at the time the motor home was built.

The chassis 12-volt DC electrical system includes:

- the vehicle batteries
- engine charging system
- ignition system
- instrument panel and control systems
- the headlights, taillights, turn signals systems
- other vehicle lights and accessories systems

The four locations for chassis fuses, breakers, relays, diodes, flashers and solenoids are:

- Front Panel ..... Under the Instrument Bonnet
- Rear Panel ..... Battery Compartment
- Engine Preheat ..... Under the Bedtop Engine Access Lid
- Engine Disconnect Switch .... Rear Engine Access Compartment

If replacement of an electrical component is needed, use only equivalent types as marked on the component.

See section "46-Specifications" in this manual and the **Electrical** section in the **Chassis Operator's/Owner's Guide/Manual** for more information.

# ELECTRICAL CHASSIS SYSTEMS

---

## **AUXILIARY START SYSTEM**

You can use the **Auxiliary Start System** to start the chassis engine or the generator with the house batteries if the chassis batteries are discharged.

To use the **Auxiliary Start System** to start the chassis engine:

1. Be sure the motor home is stopped. Shift the transmission to **N** and apply the parking brake.
2. Press and hold the **AUXILIARY START** switch on the instrument panel.
3. Start the chassis engine with the ignition switch.
4. Release the **AUXILIARY START** switch.

To use the **Auxiliary Start System** to start the generator:

1. Press and hold the **AUXILIARY START** switch on the instrument panel.
2. Press the **GENERATOR START** switch until the generator is running.
3. Release the **AUXILIARY START** switch.

---

---

### **12-VOLT SYSTEM**

All 12-volt lighting fixtures, convenience outlets, 12-volt powered vents, fresh water pump, and 12-volt accessories are included in this system.

The 12-volt power is provided by four, special deep-cycle, high capacity 6-volt coach storage batteries located in trays in the battery compartment. Power is also provided by an AC/DC power converter for use when the motor home is plugged into a 120-volt power source or when operating the generator. Battery charge is maintained by the motor home engine alternator, or by the converter. A power inverter supplies 120-volt power from these batteries.

*NOTE: All living area radios and tape decks draw from the chassis or house batteries, and extended usage when not traveling may discharge them.*

### **BATTERY DISCONNECT**

*(Also see CHASSIS ELECTRICAL SYSTEM chapter)*

Some accessories or equipment such as clocks, radios, or the refrigerator may draw small amounts of current even when turned "OFF". A relay-operated disconnect system allows you to disconnect either the chassis batteries or the coach batteries or both. Disconnecting the batteries will help reduce the likelihood of battery discharge over long storage periods.

Battery disconnect switches are located by the entry door.

If you plan to store the motor home for over ten days, press switches to OFF. Remember to press switches to ON when the motor home is taken out of storage.

A chassis battery disconnect switch is located in the engine compartment. This switch disconnects the chassis battery system from the outside of the motor home during chassis service.

# ELECTRICAL HOUSE SYSTEMS

## 12- and 120-VOLT

---

### WARNING

Do not use the motor home when the coach batteries are disconnected. The power step will not operate if the coach batteries are disconnected.

### WARNING

Disconnecting both batteries will disable the LP gas leak detector.

## ***BATTERY INSPECTION AND CARE***

### WARNING

Disconnect the 120-volt electric shore cord and the negative terminal from the coach and chassis batteries before working on either electrical system.

### WARNING

Remove rings, metal watchbands, and other metal jewelry before working around batteries. Use caution when using metal tools. If a tool contacts a battery terminal or metal connected to it, a short circuit could occur which could cause personal injury, explosion or fire.

### WARNING

Do not allow battery electrolyte to contact skin, eyes, fabrics, or painted surfaces. The electrolyte is a sulphuric acid solution which could cause serious personal injury or property damage. Wear eye protection when working with batteries.

Check the external condition of the battery periodically. Look for cracks in the cover and case. Check the vent plugs and replace if they are cracked or broken. Keep the battery clean. Accumulations of acid film and dirt may permit current to flow between the terminals and discharge the battery.

---

To clean the battery, wash it with a diluted solution of baking soda and water to neutralize any acid present, then flush with clean water. Foaming around terminals or on top of the battery is normal acid neutralization. Avoid getting the soda solution in the battery. Be sure the vent caps are tight. Dry the cables and terminals. Do not use grease on the bare metal inside the cable terminals to prevent corrosion. Grease is an insulator. Electricity will not flow through it. A plastic ignition spray will protect the terminals after you have cleaned and reinstalled them.

Check the battery, including water level, often. Keep the carrier and hold down hardware clean and free of corrosion and chemical accumulation.

### **BATTERY CHARGING**

Both sets of batteries will be kept charged by the chassis charging system while on the road. The AC/DC power converter will also charge both sets of batteries when plugged into 120-volt service or if the generator is running. If the batteries are disconnected while the coach is plugged in, they will not be charged. On those occasions when the battery needs to be charged from a different charging source, please follow these safety guidelines:

Leaving a charger connected to a battery for an extended period of time can shorten battery life.

### **WARNING**

**Never expose the battery to open flame or electric spark. Chemical action in the battery generates hydrogen gas which is flammable and explosive. Do not allow battery electrolyte (acid) to contact skin, eyes, fabrics, or painted surfaces.**

Do not smoke near batteries being charged or which have been recently charged. Please note that batteries are being charged while you drive, and while you are connected to 120-volt power through the converter/charger circuit, plugged into 120-volt service or when the generator is running.

# ELECTRICAL HOUSE SYSTEMS

## 12- and 120-VOLT

---

Do not break live circuits at the terminals of the battery. Use care when connecting or disconnecting booster leads or cables. These actions, and poor connections, are a common cause of electrical arcs which can cause explosion.

Check and adjust the electrolyte level before charging. Fill each cell to the indicator with distilled water.

Always remove vent caps before charging the battery.

Do not charge the battery at a rate that causes the electrolyte to spew out.

### **SOLAR PANEL**

The solar charging panel installed on the roof of your motor home is designed to "trickle-charge" your battery system. It is not intended to be a fast charging or heavy current electrical source. During periods of clear sky and bright sun, the solar panel will help keep your batteries "topped-up". Do not try to operate the inverter or other 12-volt DC appliances with the output of the solar panel.

The panel is expandable with optional expansion panels. Contact your dealer for more information on expansion panels.

### **SELECTING A REPLACEMENT BATTERY**

When the battery requires replacement, always choose a battery with the same physical and electrical characteristics as the original equipment. Your dealer or an authorized Fleetwood Service Center can advise you on proper battery selection.

### **120-VOLT SYSTEM**

This system provides grounded electrical service for appliances such as air conditioners, TV, microwave ovens, etc. This system also provides a power source for the converter.

# ELECTRICAL HOUSE SYSTEMS

## 12- and 120-VOLT

11  
Page 5 of 8

Your motor home is equipped with an energy management system with one heavy duty, 50-amp power cord. This cord is used to connect to external 120-volt AC service. The cord will supply power to all 120-volt appliances and outlets. The cord and connector is molded together to form a weatherproof cable assembly. Do not cut or alter the cable in any way. Do not remove the ground pin in the cable connector, or defeat the ground circuit in the motor home.

### **POWER CORD HOOK-UP**

To connect the power cord to external service, push the plug straight into the receptacle until it seats completely. See the illustration.

#### **WARNING**

Do not operate the 120-volt electrical system without a proper ground. Electrocutation or severe electrical shock could result.

#### **CAUTION**

Lightning strikes during thunderstorms may affect the electrical systems in your motor home. Sensitive electronic equipment may be damaged by the electrical spikes and surges caused by electrical disturbances in the atmosphere. Disconnect the electrical power cord and cable TV service if you expect atmospheric electrical disturbances.

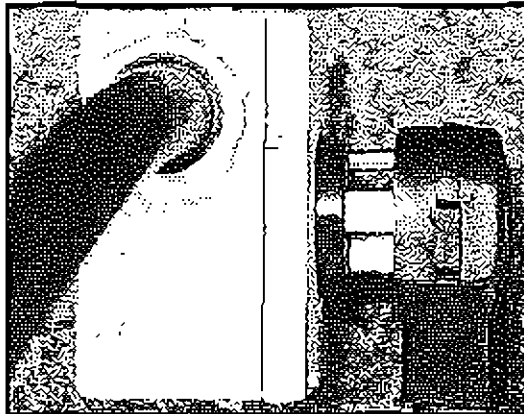

*For proper power cord hook-up, continue pushing plug in until completely seated.*

# ELECTRICAL HOUSE SYSTEMS

## 12- and 120-VOLT

---

### CAUTION

Switch off the 50-amp main breakers located in the 120-volt AC circuit breaker panel (located at the foot of the bed) before you insert or remove the 50-amp power plug. Be sure to insert or remove the plug straight into or out of the receptacle. The neutral and both 120-volt pins should make contact at the same time to avoid excessive voltage on one leg of the circuit that could damage 120-volt appliances.

### POWER CONVERTER

The converter will automatically supply 12-volt power when your motor home is operating on 120-volt from the generator or a public utility. It will also charge both sets of batteries.

### POWER INVERTER

The power inverter is designed to provide power to all appliances except the roof air conditioners and electrical panel 2 which includes the washer/dryer, roadside patio receptacle, refrigerator and power converter. The inverter uses 12-volt DC power from the coach batteries and transforms it into 60-cycle, 120-volt AC power to run most of the appliances in the motor home. Controls are located on both the inverter faceplate in the exterior roadside utility compartment and in the dinette overhead.

*Note: The roof air conditioners cannot be operated on power supplied by the inverter. The motor home must be plugged into an external AC service or the generator must be operating to run the air conditioners.*

Because the inverter uses 12-volt power, extended use of any available appliance (TV, microwave, etc.) can run the batteries down. A low power indicator and automatic shut-down system built into the inverter can help prevent deep battery discharge. When the inverter shuts down, the batteries will require recharging through the converter when the motor home is plugged into external AC service or when operating the generator. The batteries will also be recharged by the chassis charging system while on the road.



### **GROUND FAULT INTERRUPTER**

Bathroom, galley and patio 120-volt electrical outlets are protected by a Ground Fault Interrupter (GFI). This device is intended to protect you against the hazards of electrical shocks possible when using electrical appliances in the bathroom or galley or in damp areas. Should a circuit or appliance (electric shaver, hair dryer, etc.) develop a potential shock hazard, the GFI device is designed to disconnect the outlet (and other outlets on the same circuit), limiting your exposure time.

*NOTE: If an outlet doesn't work, check the GFI. Reset it if necessary. If the GFI continues to trip, have the motor home electrical system checked at an authorized Fleetwood Service Center or by a qualified electrician.*

Test the GFI at least once a month. To test the GFI, connect the electrical system to 120-volt AC service:

Push the **TEST** button. The **RESET** button should pop out, indicating that the protected circuit has been disconnected.

**If the reset button does not pop out when the test button is pushed, a loss of ground fault protection is indicated. Do not use any electrical outlets. Have the motor home electrical system checked at an authorized Fleetwood Service Center or by a qualified electrician. Do not use the system until the problem has been corrected.**

To restore power push the "RESET" button.

Your **Owner's Information Package** contains a card that can be used to record test dates. Keep the card in a conspicuous place and keep it up to date.

# ELECTRICAL HOUSE SYSTEMS

## 12- and 120-VOLT

---

### **HOUSE FUSES AND CIRCUIT BREAKERS**

This motor home uses a combination of fuses and circuit breakers in the house 12-volt DC and 120-volt AC systems to protect individual circuits.

The fuses are electrical safety devices with a fusible strip of metal that melt and interrupts the circuit when the current exceeds a particular amperage. If the circuit is overloaded, it will blow the fuse and the fuse must be replaced. Check the circuit for an overload. Remove the overload and replace the fuse with the same type and amperage rating.

A circuit breaker is a switch that automatically interrupts an electric circuit under an infrequent abnormal condition. If a circuit breaker is tripped, look for an overload on the circuit, remove the overload, then reset the breaker. Some breakers are reset by pushing in a button, others by turning the switch OFF then ON. Do not try to reset a breaker the second time without removing the overload problem.

See section "48-Specifications" of this manual for information of circuit descriptions, ratings and locations.

### **WARNING**

**Do not install fuses or breakers with amperage ratings greater than that specified on the device or label. Doing so constitutes a fire hazard.**

# ELECTRICAL SYSTEM WIRING

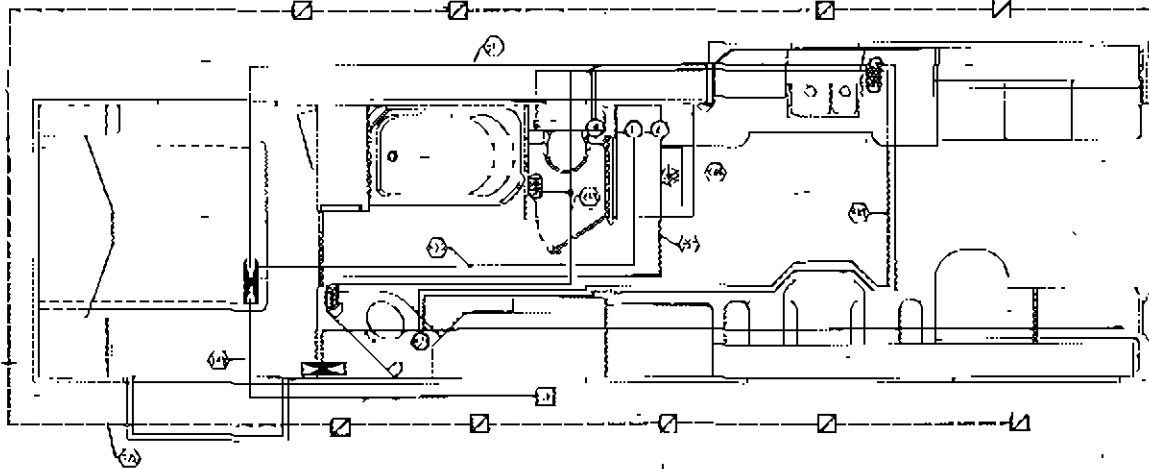

INTERIOR MODEL 40 OR 17 VOLT INTERIOR CIRCUITS

- |                                 |                    |                              |                    |
|---------------------------------|--------------------|------------------------------|--------------------|
| (1) 10A METER                   | 20 GA. BLU         | (14) 15A FRONT PUSHPACK      | 13 GA. RED W/BLACK |
| (2) 15A LUGGAGE COMPARTMENTS    | 11 GA. BKY         | (15) 15A WATER PUMP SWITCH   | 20 GA. GRN         |
| (3) 15A WATER PUMP/WATER HEATER | 12 GA. RED         | (16) 15A WATER HEATER SWITCH | 19 GA. BRN/GRN     |
| (4) 15A REAR PUSHPACK           | 12 GA. RED W/WHITE | (17) 15A WATER HEATER LIGHT  | 12 GA. BLU         |

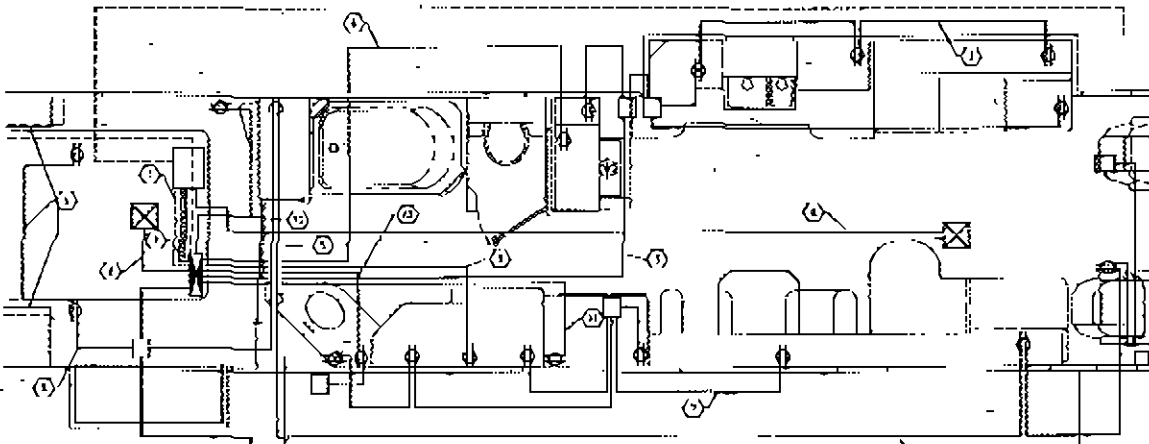

EXTERIOR MODEL 40 OR 17 VOLT EXTERIOR CIRCUITS

- |                              |            |                             |            |
|------------------------------|------------|-----------------------------|------------|
| (1) 20A MISC #1              | 8-2 W/GRN  | (14) 20A APC #3             | 17-2 W/GRN |
| (2) 20A APC #1               | 12-2 W/GRN | (15) 15A WASH/DRYER         | 17-2 W/GRN |
| (3) 20A POSITIONAL APPLIANCE | 12-2 W/GRN | (16) 25A RANGE/STOVE RECEPT | 17-2 W/GRN |
| (4) 20A LOCAL PUMPAGE        | 13-2 W/GRN | (17) 25A REFRIGERATOR       | 13-2 W/GRN |
| (5) 20A MICROVAPE            | 13-2 W/GRN | (18) 15A SWITCH WATER       | 13-2 W/GRN |
| (6) 20A MISC #2              | 8-2 W/GRN  |                             |            |

# ELECTRICAL SYSTEM WIRING

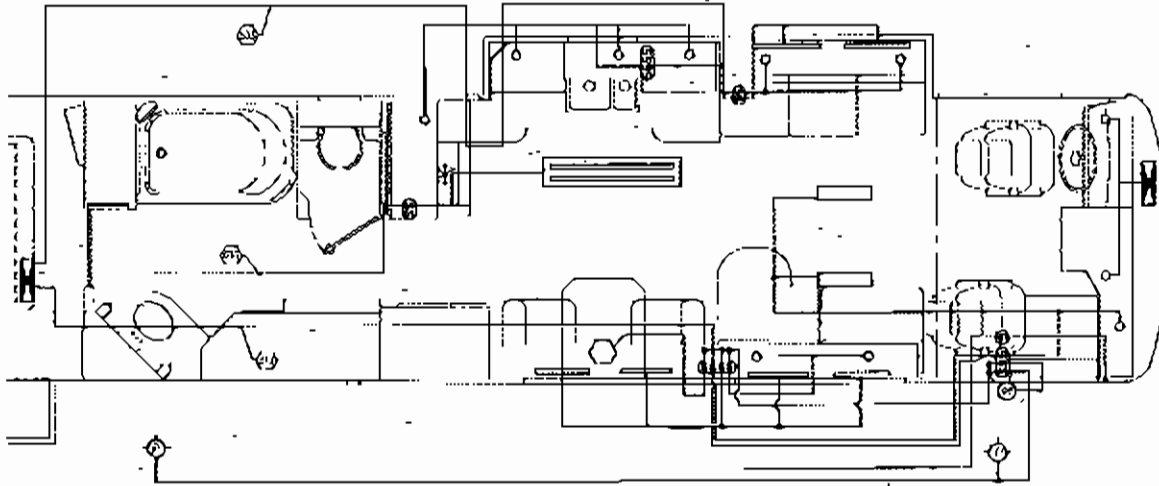

DREAM MODEL 40.05 12 VOLT GALLEY/LIVING AREA CIRCUITS

- |      |                                     |              |      |                           |
|------|-------------------------------------|--------------|------|---------------------------|
| (61) | FOR GALLEY                          | 12 GA PUR    | (65) | OSBORNE LIVING AREA POWER |
| (62) | FOR GALLEY CEILING LT.              | 12 GA PURPLE | (66) | FOR FLOODLIGHT            |
| (63) | FOR LIVING AREA CEILING 1Y SW.      |              |      |                           |
| (64) | FOR LIVING AREA #1 (BANKETS LIGHTS) | 12 GA YELLOW |      |                           |

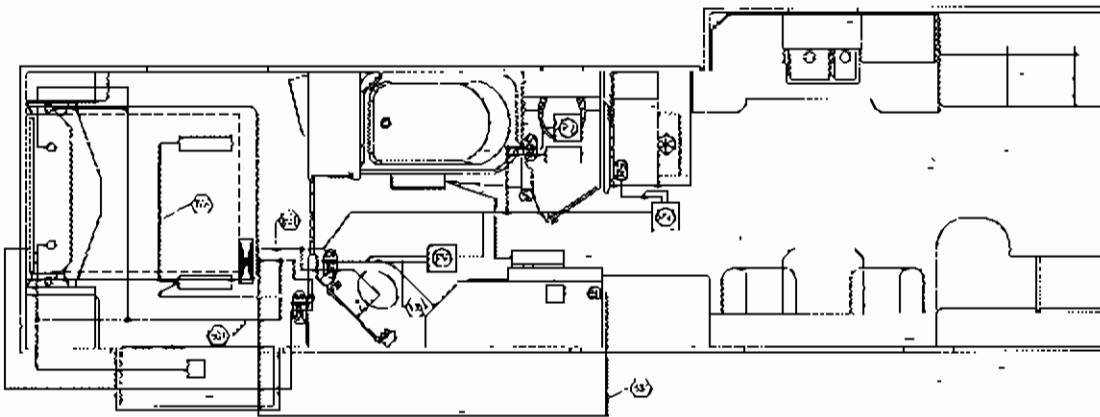

DREAM MODEL 40.05 12 VOLT BEDROOM/RADI AREA CIRCUITS

- |      |                  |            |
|------|------------------|------------|
| (67) | FOR BEDROOM AREA | 12-1 BROWN |
| (68) | FOR RADI AREA    | 12-1 GREEN |

# ELECTRICAL SYSTEM WIRING

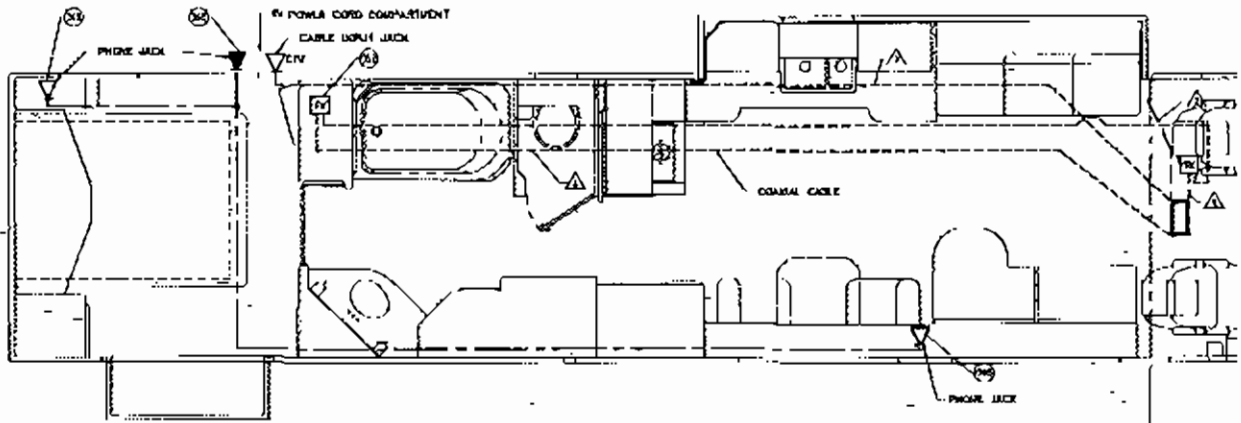

DREAM MODEL 40 DS COAX WIRING

▲ FROM ROOF ANTENNA TO "ANTENNA IN"  
▲ FROM CABLE INPUT TO "PAY TV OUTPUT"

▲ FROM TV TO "MAIN TV" OUTPUT  
▲ REAR TV(S) TO "TV IN" OUTPUT

# ELECTRICAL SYSTEM WIRING

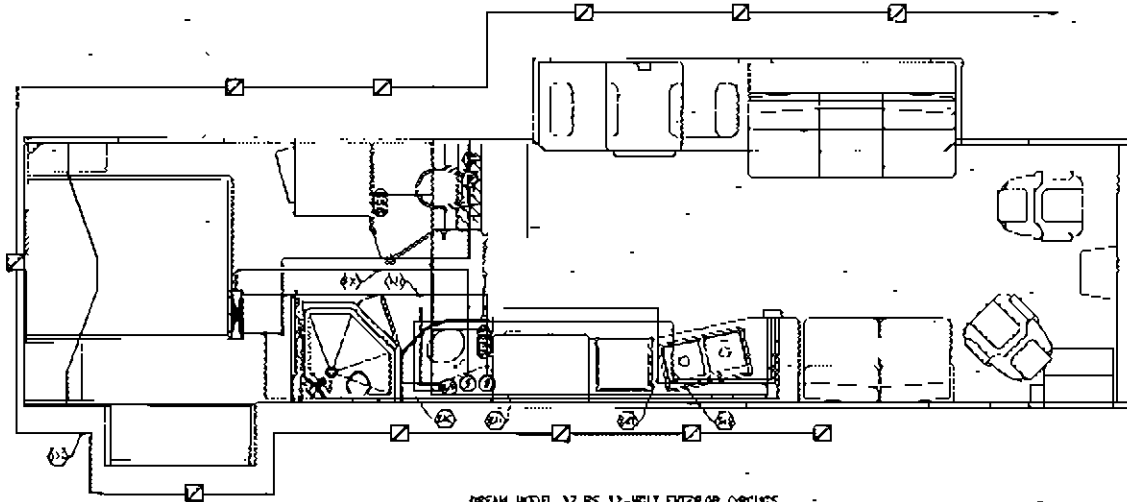

**MODEL 37 RS 12-VOLT EXTERIOR CIRCUITS**

- |                            |                   |                          |             |
|----------------------------|-------------------|--------------------------|-------------|
| ① 15A Luggage compartments | 14 GA BROWN       | ⑩ 15A WATER PUMP SWITCH  | 20 GA GRAY  |
| ② 15A WIRE PUMP/WRM HEATER | 18 GA RED         | ⑪ 15A BATH HEATER SWITCH | 12 GA BROWN |
| ③ 15A REAR FURNACE         | 12 GA RED W/WHITE | ⑫ 15A WASH HEATER LIGHT  | 12 GA BLUE  |
| ④ 15A FRONT FURNACE        | 12 GA RED W/BLACK |                          |             |

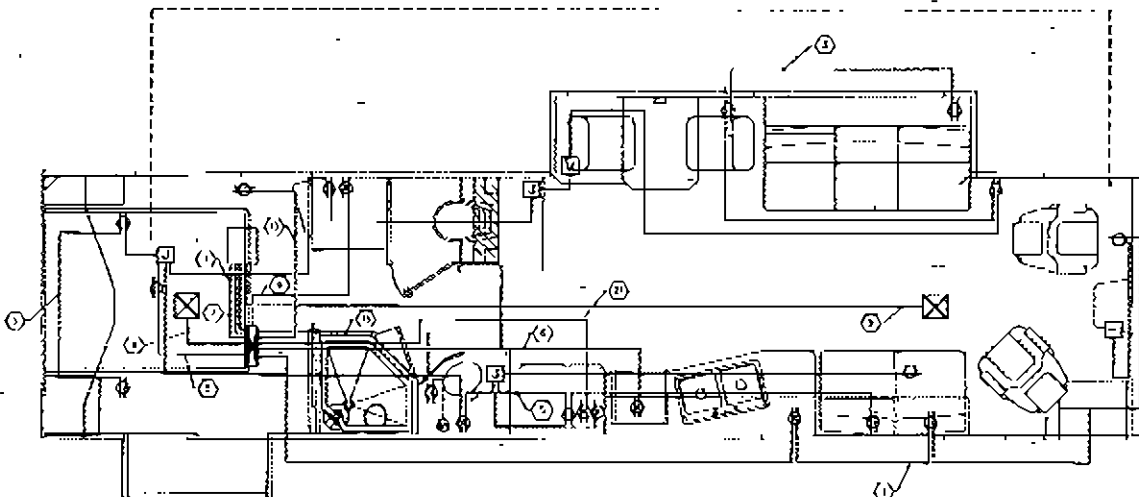

**MODEL 37 RS 12-VOLT INTERIOR CIRCUITS**

- |                        |                   |                          |                        |
|------------------------|-------------------|--------------------------|------------------------|
| ① 30A MAIN #1          | 8-2 W/GRN         | ⑩ 20A A/C #3             | 11-2 W/BLK ORANGE/BLUE |
| ② 30A A/C #1           | 12-2 W/GRN ORANGE | ⑪ 15A BATH/WC/DRYER      | 11-2 W/GRN BLK         |
| ③ 30A PORTABLE APPLNCL | 12-2 W/BLK GRAY   | ⑫ 15A READING P/TO RECVY | 11-2 W/GRN YELLOW      |
| ④ 30A CLOSET FURNACE   | 12-2 W/GRN ORLN   | ⑬ 15A RECVY/AV/CR        | 11-2 W/GRN BK          |
| ⑤ 30A W/DRY/WR         | 12-2 W/GRN VOLT   | ⑭ 15A WATER HEATER       | 11-2 W/GRN WHITE       |
| ⑥ 30A MAIN #2          | 8-2 W/GRN         |                          |                        |

# ELECTRICAL SYSTEM WIRING

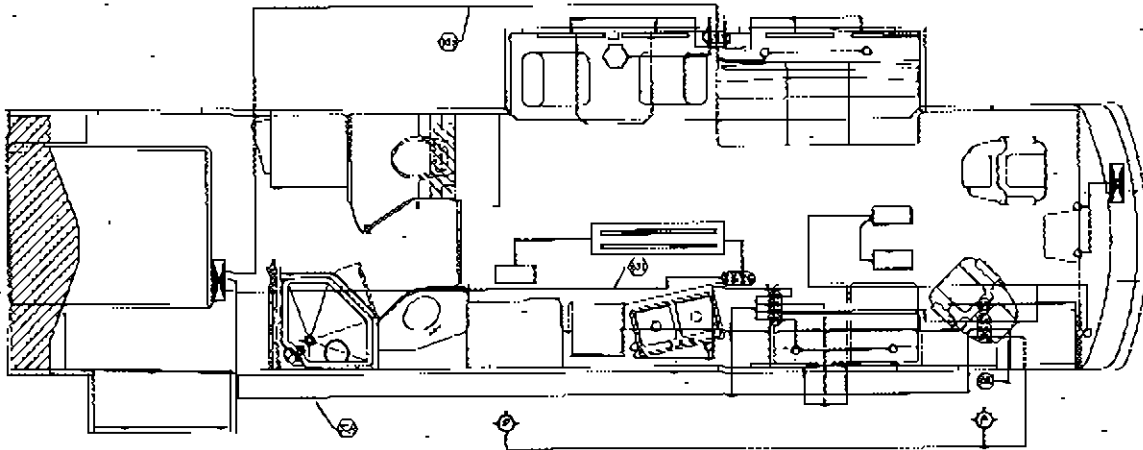

DREAM MODEL 37 RS 12 VOLT GALLEY/DINING AREA CIRCUITS

107-7916 BEAR Q'HEAD WIRING

- |   |                        |              |
|---|------------------------|--------------|
| ① | 20A. DINING AREA       | 12 GA YELLOW |
| ② | 20A. GALLEY            | 12 GA BLACK  |
| ③ | 20A. GALLEY CEILING LI | 12 GA PURPLE |

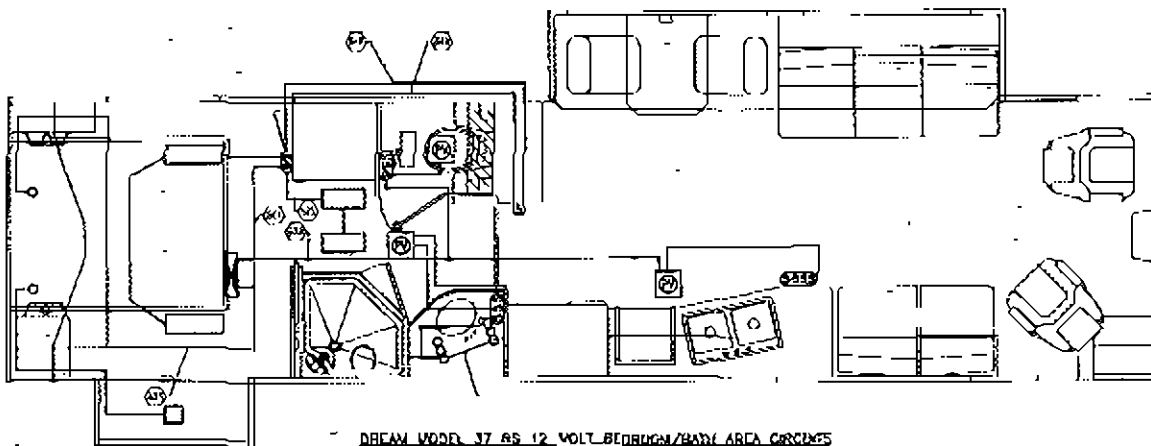

DREAM MODEL 37 RS 12 VOLT BEDROOM/BATH AREA CIRCUITS

107-7916 BEAR Q'HEAD WIRING

- |   |                      |             |   |                       |             |
|---|----------------------|-------------|---|-----------------------|-------------|
| ④ | 20A. BEDROOM AREA    | 12 GA BROWN | ⑧ | 20A. BATH AREA        | 12 GA GREEN |
| ⑤ | 20A. BED CEILING LLS |             | ⑨ | 20A. BATH CEILING LLS |             |
| ⑥ | 20A. BATH SW PLUNGER |             | ⑩ | 20A. BATH SW PLUNGER  |             |

# ELECTRICAL SYSTEM WIRING

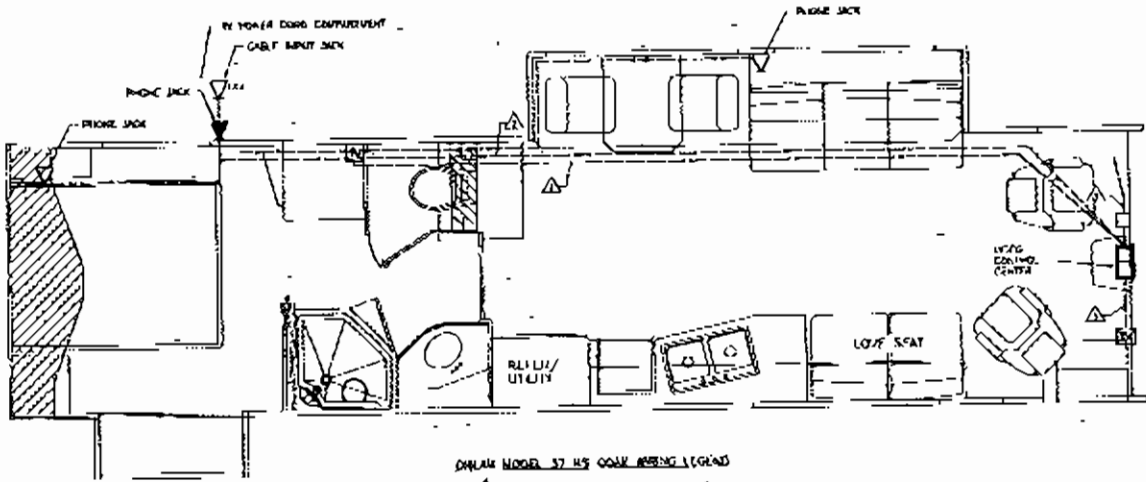

DRAWING NUMBER 37 IS COVER WIRING LEGEND

- ▲ FROM ROOF ANTENNA TO ANTENNA IN
- ▲ FROM CABLE INPUT TO "PAC TV INPUT"
- ▲ FROM TV TO "PAC TV" OUTPUT
- ▲ FROM TV TO "TV EX" OUTPUT



# ELECTRICAL SYSTEM WIRING

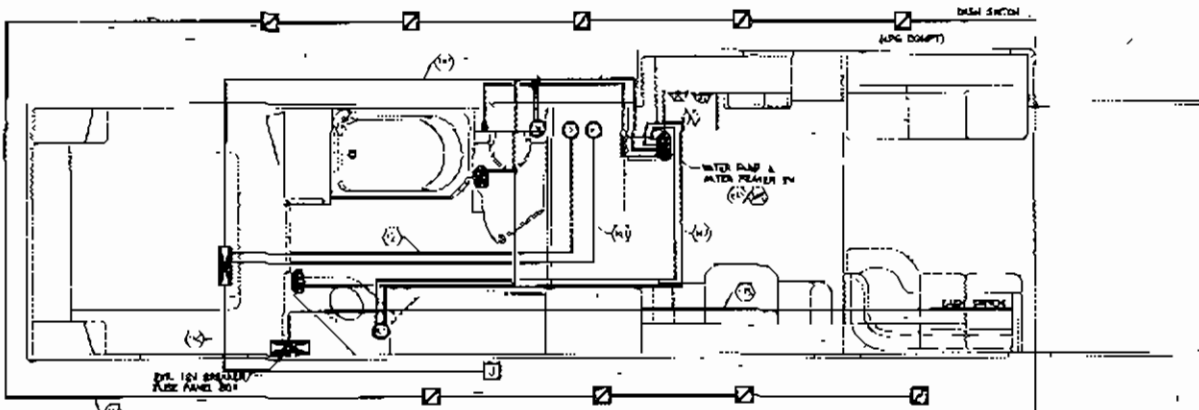

**VS MODEL 120 VOLT EXTERIOR CIRCUITS**

- |                               |                         |                             |                         |
|-------------------------------|-------------------------|-----------------------------|-------------------------|
| (1) 10A MELZER                | (4) 1A GA. BLUE         | (7) 15A FROG PLUG/POLE      | (12) 12 GA. RED W/BLACK |
| (2) 10A LUGGAGE COMPARTMENT   | (5) 1A GA. WHITE        | (8) 15A WATER PUMP SWITCH   | (13) 10 GA. ORANGE      |
| (3) 15A WATER PUMP/WTR HEATER | (6) 1A GA. RED          | (9) 15A WATER HEATER SWITCH | (14) 12 GA. BROWN       |
| (4) 15A AREA PLUG/POLE        | (11) 1A GA. RED W/WHITE | (10) 15A WATER HEATER LIGHT | (15) 12 GA. BLUE        |

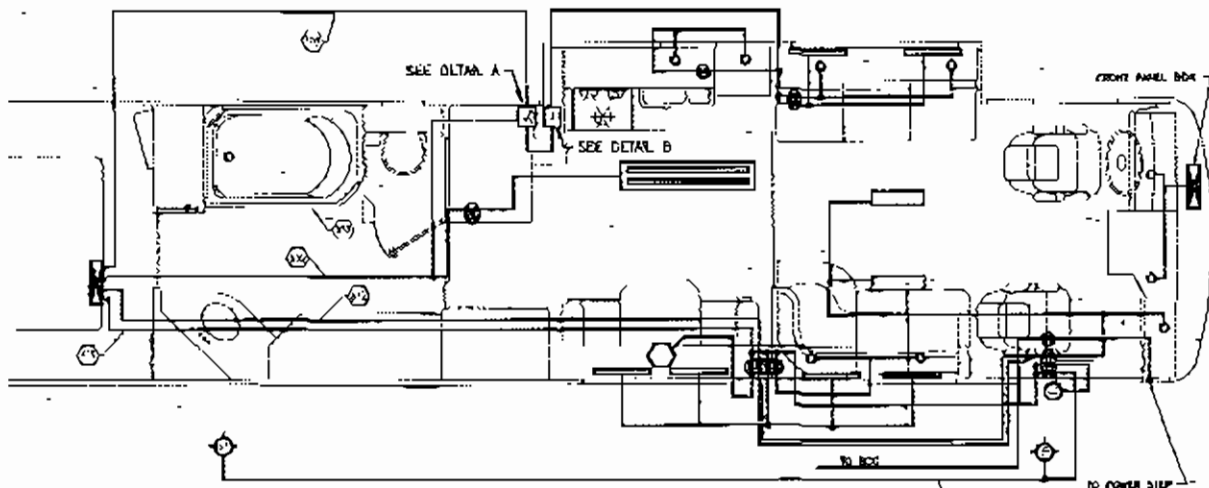

**VS MODEL 120 VOLT INTERIOR CIRCUITS**

- |                           |   |                   |
|---------------------------|---|-------------------|
| (1) 10A GALLEY            | (4) 20A LIVING AREA #1 (DINETTE LIGHTS) | (8) 12 GA. YELLOW |
| (2) 10A GALLEY CEILING LI | (5) 20A LIVING AREA #2 (DINETTE LIGHTS) | (9) 12 GA. BLUE   |
|                           | (6) DOOR/DOOR LIVING AREA POWER         |                   |

# ELECTRICAL SYSTEM WIRING

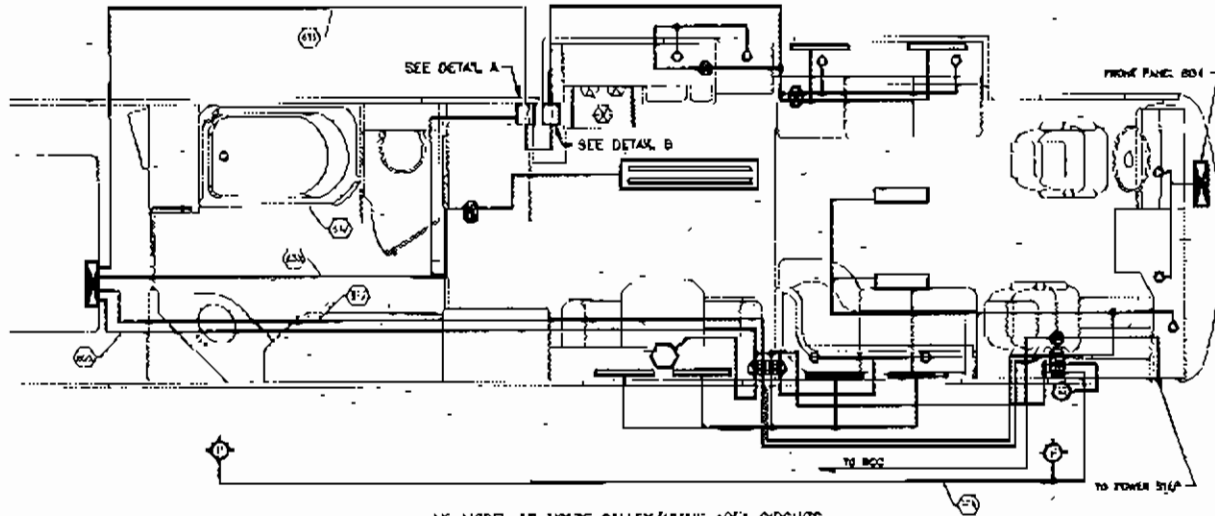

VS MODEL 12-VOLTS GALLEY/LIVING AREA CIRCUITS

- (11) 20A GALLEY
- (12) 20A GALLEY CEILING LT.
- (13) 20A LIVING AREA #1 (SMIETTE LIGHTS) 12 GA. YELLOW
- (14) 20A LIVING AREA #2 (SMIETTE LIGHTS) 12 GA. BLUE
- (15) DOORSIDE LIVING AREA POWER

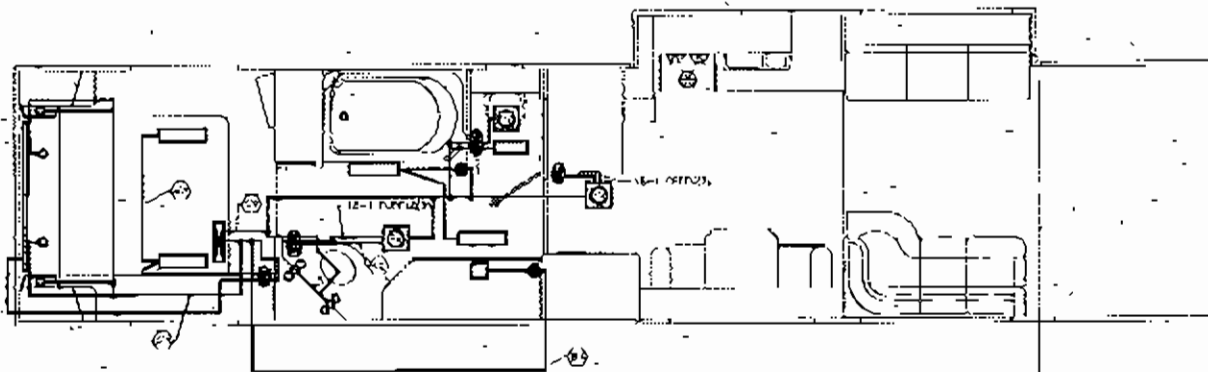

VS MODEL 12-VOLTS BEDROOM/BEACH OFFICE

- (16) 20A BEDROOM AREA 12-1 BROWN
- (17) 20A BEACH AREA 12-1 GREEN

# ELECTRICAL SYSTEM WIRING

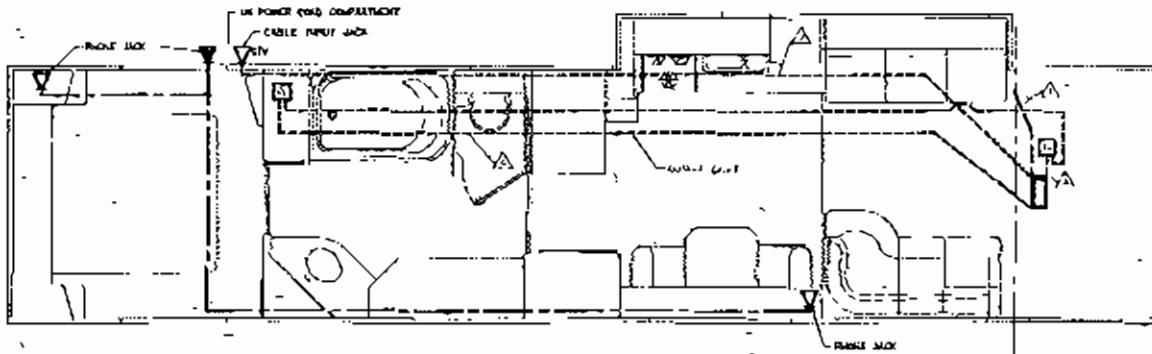

VS MODEL COAX WIRING

▲ FROM ROOF ANTENNA TO "ANTENNA IN"  
▲ FROM CABLE INPUT TO "PAY TV INPUT"

▲ FROM TV TO "MAIN TV" OUTPUT  
▲ FROM SW(S) TO "TV 60" OUTPUT

This page intentionally left blank.

## CAUTION

Do not allow your motor home to be towed without having the tow truck operator read this section and related sections of the Chassis Operator's/Owner's Guide/Manual. Always comply with all state and local laws when towing the motor home.

## WARNING

**DO NOT** crawl under or place any part of your body under a vehicle that is being lifted. Stand clear of all towing equipment and the vehicle being lifted.

If your motor home needs to be towed, please use the following guidelines:

See the **Chassis Operator's/Owner's Guide/Manual**. The vehicle **MUST** be towed from the front.

## CAUTION

Do not tow the motor home from the rear. Towing from the rear will cause serious overloading of the front tires and suspension, possibly resulting in tire or front suspension failure.

- Tow truck operators willing and able to tow motor homes will be familiar with the type of device required to tow your motor home.

Be prepared to give the tow truck operator at least the following information when you call:

length and height of motor home

chassis manufacturer

gross vehicle weight rating

## EMERGENCY TOWING

---

### CAUTION

**Remove the axle shafts or disconnect the driveline before towing the motor home**

To prepare your motor home for towing:

1. The rear axle shafts or the driveline **MUST** be removed before towing. See the **Chassis Operator's/Owner's Guide/Manual**.
2. Secure any loose or protruding body parts of the disabled vehicle.
3. Secure any heavy, loose items in the interior.
4. Turn off LP gas appliances and the LP gas tank valve.
5. Do not allow any person to ride in the towed vehicle.
6. Contact the chassis assistance center prior to calling a tow company to receive tow instructions and possible assistance with coordinating the tow.

### CAUTION

**The air brake system and air suspension system may require recharging with air before towing to release the brakes and provide proper ride height. An air inlet fitting is located in the front left hand (roadside) compartment. Tow truck operators should be equipped to re-charge these air systems.**

---

The chassis engine access cover is located under the bed in the rear sleeping area.

## WARNING

The engine cover combined with the weight of any bedding may be quite heavy. Be sure the engine cover support is securely set.

To open the top engine cover:

1. Lift the foot end of the bed top.
2. Unlatch the engine cover latches.
3. Lift the engine cover and latch it to the bed top with the latch installed in the bed top.

## WARNING

When installing the engine cover, be sure the cover is fully seated on the gasket seal. Do not allow any material to interrupt the seal between the cover and the engine compartment. If the engine cover is not installed correctly, engine exhaust gases could leak into the passenger compartment creating a safety hazard. If the engine must be run with the engine cover off for maintenance purposes, be sure the vehicle interior is adequately ventilated.

This page intentionally left blank.



---

SEE CHASSIS OPERATOR'S/OWNER'S GUIDE/MANUAL FOR DETAILS ON ENGINE OPERATION AND MAINTENANCE.

## **NORMAL STARTING PROCEDURE**

1. Shift transmission to **NEUTRAL**.
2. Turn ignition switch to the right (clockwise) to the first position. The **WAIT TO START** light on the instrument panel will light up. When the **WAIT TO START** light goes out, turn the switch clockwise to the **START** position. When the engine starts, release the switch. See **"Driver's Controls"** for location of **WAIT TO START** light.

*NOTE: The WAIT TO START feature is necessary for engine intake air preheating. The operating timing interval depends on engine and outside air temperature. The light will go off sooner if the engine is hot and/or the outside air temperature is warm.*

The engine is equipped with a block-heater to aid in cold-weather starting. Plug-in connections for the engine block heater are located in the electrical shore cord compartment.

## ENGINE OPERATION

---

### CAUTION

To prevent damage to the starter, do not engage the starting motor for more than 30 seconds. Wait two minutes between each attempt to start.

Engine oil pressure must be indicated on the gauge within 15 seconds after starting.

When starting a cold engine, increase the engine speed (RPM) slowly to be sure adequate lubrication is available to the bearings and to allow the oil pressure to stabilize.

Idle the engine 3 to 5 minutes at 1000 RPM before operating with a load.

Check the oil pressure indicator(s), temperature indicator(s), and other gauges daily to make sure they are operating correctly.

The motor home will not move until the air brakes and suspension systems are sufficiently full of air. Nominal brake system air pressure is 90-120 psi. The motor home cannot be moved until at least 60 psi is indicated on the air brake pressure gauge.

## ***NORMAL SHUT-DOWN PROCEDURE***

1. Shift transmission into **NEUTRAL**.
2. Pull out on the **Parking Brake** knob to engage the parking brake.
3. Let engine idle for a minimum of 3 minutes for proper cool down. Increase this time if there has been extended hot weather running.

## **WARNING**

- The transmission does not have a **PARK** position.
- Place the transmission in neutral (N) and set the parking brake when parking the motor home.

This page intentionally left blank...

If additional equipment requiring 12-volt power is installed in the motor home, obtain the 12-volt source from a properly fused battery circuit, located under the dash bonnet. Consult an authorized Fleetwood dealer before adding any additional equipment to your motor home.

## **VIDEO CASSETTE RECORDER**

The VCR operates on 120-volt power from the generator, public utility, or the inverter (powered by 12-volts DC). Both TVs operate on 120-volts AC power from the generator, public utility, or the inverter (powered by 12-volts DC).

**To operate the VCR on 12-volts DC:** Turn the power inverter ON at the remote panel in the dinette overhead. The inverter changes 12-volt battery power to 120-volts AC. Turn the VCR and TV ON. To protect the TV and VCR circuits, a low battery feature will turn off the inverter and illuminate a red light when battery power is low. The inverter will automatically start when the batteries are recharged.

Turn the inverter off when not in use or when 120-volt power is available because there is a small drain on the batteries even if the TV and VCR are off.

*Note: Extended use of 120-volt appliances through the inverter will discharge the batteries. Although the inverter will shut down before complete battery discharge, battery power remaining may not be enough to power other 12-volt devices connected to the 12-volt DC system. Re-charge batteries fully after inverter shut-down.*

## **TV ANTENNA**

The roof-mounted antenna is designed for reception of VHF and UHF television signals.

Before traveling, remember to lower the antenna and secure it to prevent damage to the antenna, motor home roof, or objects in the path of the antenna, such as overhead wires. **Do not travel with the antenna raised.**

*NOTE: The antenna booster power supply, located in the front overhead compartment above the driver's seat, must be turned off to prevent battery drain. A red indicator light will glow when the unit is on.*

### **TV GHOSTS AND FM FLUTTER**

The television and radio systems in your motor home have been chosen to provide good performance under varied signal conditions. Occasionally, though, you may experience "ghosts" on TV or "flutter" when listening to FM broadcasts.

If distortion becomes a nuisance, try these tips:

Use the "park cable" TV antenna in remote areas rather than the roof antenna of your motor home if the campground provides cable hook-up.

Re-orient the antenna. Sometimes turning the antenna will pick up a stronger signal from a different direction.

With FM Stereo signals, switch the unit to MONO, if possible. Some of the phase and noise components of a stereo signal will disappear in MONO mode.

Reduce the treble setting to reduce background noise. Although not yielding the best high-frequency performance, at least you may be able to reduce the irritation of the distortion.

---

## **FRONT TV POWER LIFT**

The TV lift will raise the front TV to any height between the floor and ceiling. The lift operates on 120-volt AC power from the generator, a public utility, or the inverter (operating on 12-volts DC). The lift switch is located on the passenger side of the dash panel.

To operate the lift:

*Note: The motor home ignition key must be in either the **OFF** or **ACCESSORY** position before the TV lift can be operated. 120-volt AC power must be available before operating the lift.*

1. Turn ignition key to OFF or ACCESSORY position.
2. Press and hold the top of the TV lift switch to lift TV.
3. Release switch at the desired TV height.
4. Press and hold the bottom of the switch to lower the TV.

## **DIGITAL SATELLITE SYSTEM (Optional)**

Your motor home may be equipped with a Digital Satellite System (DSS) option, please refer to your **Owner's Information Package** for additional information.

This page intentionally left blank.



The entry step is controlled by the ignition switch and by a switch located at the entry door. Power for the entry step is supplied by the house battery system. The house battery disconnect must be ON for the step to operate as described below. The switches operate the step according to the following table.

## WARNING

The distance between the motor home and the ground is too far to easily manage. Be sure the step is out before exiting the motor home.

IGNITION SWITCH POSITION	STEP SWITCH POSITION	STEP POSITION/ACTION
OFF	ON	Step extends and retracts with the opening and closing of the door. Light under step will be on.
OFF	OFF	Step is inactive. Will not move regardless of door movement. Light under step will be off.
ON	ON	Step extends and retracts with opening and closing of door. Light under step will be on.
ON	OFF	Step extends and retracts with opening and closing of door. Light under step will be off.

*NOTE: This motor home is equipped with a "Last Out Feature" on the entry step. It automatically extends the step if: the ignition switch is TURNED OFF, the step position switch is OFF, and the entry door is OPENED. It will remain extended until door is closed and either the ignition or step position switch is turned on.*

## ENTRY STEP

---

### ***PNEUMATIC STEPWELL COVER***

Your motor home is equipped with an air operated slideout stepwell cover. The stepwell cover closes off the stepwell area when you are traveling. When the cover is extended, it provides a floor surface for the front seat passenger.

If the chassis air storage tanks contain less than 90 psi air pressure, the stepwell cover will not function. Check the air pressure on the air pressure gauge on the driver's instrument panel.

#### **WARNING**

Do not operate the pneumatic stepwell cover while anyone is positioned in the stepwell. A person standing in the stepwell could lose their balance and fall if the stepwell cover is operated.

#### **WARNING**

Feet, legs, hands, and other body parts could be pinched or injured during stepwell cover operation. Keep clear of the stepwell cover during operation.

### ***Stepwell Cover Operation***

1. The stepwell cover control is located on the passenger side of the overhead.
2. To extend the cover, move the control switch forward.
3. To retract the cover, move the control switch rearward.
4. The stepwell cover can be pushed in manually to retract. To retract the cover manually:
  - a. Be sure that the dash air pressure gauge shows no pressure (0 psi).
  - b. The top surface of the cover should drop a couple of inches. If it doesn't, move it slightly by hand.
  - c. Push the cover into the retracted position.

Your motor home engine has been designed to conform to Federal and State emission requirements. To meet these requirements, engine operating temperatures are high. As a result, the engine and exhaust systems radiate a great deal of heat.

Special heat shields are built into your motor home to protect wiring and other components from possible heat damage caused by the exhaust system.

## **CAUTION**

**Do not remove these shields, modify the exhaust system, or add additional equipment, such as wiring, plumbing, or other components, which will be affected by exhaust system heat.**

This page intentionally left blank.

---

Your motor home has been designed to provide you with many years of use with a minimum amount of maintenance. This section will familiarize you with items requiring scheduled care. Time spent taking care of your motor home on a regular basis will pay for itself in extended service and will protect your investment. If you are mechanically inclined and regularly perform routine maintenance and repairs on your car or truck, you may want to do the mechanical work on your motor home yourself. If you prefer, your dealer can perform these services for you. His trained personnel will assure that your motor home is properly maintained and repaired.

This section will provide the owner and operator with a general overview of service and maintenance information for the motor home. Detailed service and maintenance information may be found in the owner's/operator's manuals contained in the **Owner's Information Package**.

While the information in this section is intended to establish proper maintenance and inspection procedures, there may be times when detailed diagnostic and repair procedures may be required. Consult your dealer or an authorized Fleetwood Service Center in these situations.

## **EXTERIOR FINISH**

Some exterior parts of your motor-home are made of fiberglass. The finish on these parts is durable, but not indestructible. Any material and finish will deteriorate in time. Exposure to sunlight, moisture and airborne pollutants can cause dulling and fading of the finish. Generally, changes in the finish due to weathering are cosmetic—they are on the surface of the part and do not affect its strength. Weathering can take the form of chalking, fading and yellowing.

## EXTERIOR MAINTENANCE

---

### Caution

The standard exterior graphics and color schemes of your motor home were carefully selected to reduce the possibility of damage to the fiberglass sidewalls. Adding excessively dark colored custom graphic designs to the exterior sidewall of your motor home may void your warranty. Excessively dark color schemes may lead to cracking of the fiberglass sidewall material by causing significant temperature variations in the fiberglass when exposed to sunlight.

*NOTE: Your motor home is equipped with a soft-lined vinyl transit cover. This cover is intended to protect the front of the motor home while traveling. If this cover has been exposed to rain, snow, or other moisture, remove it and let it completely air dry. Elements and compounds in the water and in the cover material can react with the motor home exterior fiberglass or paint and cause discoloration or staining.*

The best insurance against these effects is routine maintenance. If the finish is not washed and waxed thoroughly, the surface can deteriorate very rapidly. The following maintenance guidelines can help you reduce these weathering effects:

1. Wash the exterior with a mild soap monthly, at least. Avoid strong alkaline cleaners and abrasives.
2. Wax the exterior at least once a year—twice, if possible—with a wax formulated for fiberglass. When waxing, always read and follow the instructions and precautions on the container. Some cleaners and waxes are recommended for use on only certain types of surfaces. In some cases, a light rubbing compound may be required. Always follow rubbing compound with a high-quality wax.

## **STAINS**

Stains are generally caused by two types of substances—water soluble and non-water soluble. Water soluble stains can usually be washed away with water and mild detergent. Follow the washing with wax.

Non-water soluble stains are usually oil-based. Removal of this type of stain may require the use of highly flammable or poisonous solvents. Refer this type of service to your dealer or an authorized Fleetwood Service Center. Never use strong solvents or abrasives to clean plastic surfaces.

## **WINDOWS, DOORS, VENTS AND LOCKS**

Keep moving parts, hinges and latches adjusted and maintained. Lubricate with a light oil at least once a year. Check and tighten the screws holding the windows in place as required. Clean screens by gently wiping with a damp cloth or soft flat brush. Not all screens are removable.

Inspect the sealants around doors and windows every three months. See "Sealant Renewal" section.

Lubricate locksets in doors and exterior storage compartments at least annually. If the motor home is located at a beach or is exposed to salt air, more frequent lubrication may be required.

## **FIBERGLASS ROOF SYSTEM**

Follow the exterior finish maintenance's steps 1 and 2 concerning washing and waxing. Be sure to keep the sidewalls wet to reduce streaking when washing the roof.

**Care**

Use caution when loading sharp articles on the roof. If you add accessories or new equipment on the roof, be sure the installer is qualified to work on the fiberglass roof material. This is required under the terms of the warranty.

Repair kits are available through your dealer. The roof requires special adhesives and material.

**WARNING**

The fiberglass roof material is slippery when wet.

**SEALANT RENEWAL**

The adhesives and sealants used in the construction of your motor home were developed to remain waterproof under sustained effects of weather and vibration. However, even the finest materials will eventually dry out and lose their effectiveness under constant heat of the sun and attack by other elements. This section outlines the procedures you must follow to maintain the weatherproof integrity of your motor home. Leak damage caused by failure to follow these procedures will affect your warranty coverage.

Your dealer can perform the resealing inspection and work for you. Your dealer also has current information on sealants used in your motor home, and can recommend the appropriate sealants for you if you prefer to do this work yourself. Always use the recommended sealants. See the "SPECIFICATIONS" section of this manual for basic sealant recommendations.

**DOOR, WINDOW, ROOF COMPONENT  
AND MOLDING RESEALING**

Inspect the sealants around windows and doors at least every three months. Also inspect roof vents, other roof components, moldings at front and rear caps, and perimeter molding. If any of the following defects are evident during inspection, the affected areas must be resealed.

*Excessive amount of sealant protruding from joints*

*Sealant cracked or peeling*

*VOIDS in sealant*



*NOTE: Do not seal the bottom flanges of windows and doors. Sealant voids have been intentionally left in the bottom flange to provide exterior drainage in the event of leakage.*

If you find any of the above defects:

1. Use a plastic scraper to remove excess sealant.
2. Clean all areas to be resealed with mineral spirits and clean rags.

## WARNING

**Mineral spirits is a flammable liquid. Use extreme care when handling and using. Do not expose to open flame, sparks, or smoking material. Do not use mineral spirits in unventilated areas.**

Make sure that all areas to be resealed are absolutely dry before applying new sealant.

## STAINLESS STEEL BUMPERS

The bumpers are corrosion resistant. For routine cleaning, use soap, ammonia or detergent and water. Rinse with clean water and wipe dry.

## CAUTION

**Do not use any of the following items on stainless steel bumpers:**

**carbon steel brushes  
steel wool  
disc or orbital sanding equipment**

To remove stubborn spots and stains, use any cleaner recommended for stainless steel or a non-chlorine household cleaner. Apply with a damp sponge or cloth, rinse thoroughly and wipe dry.

To remove hard water spots, wipe the bumper with a cloth dipped in vinegar, rinse with clear water.

## EXTERIOR MAINTENANCE

---

### **ALUMINUM WHEELS**

Your motor home is equipped with aluminum wheels in the front and both aluminum and steel wheels in the rear. On the rear, the inside dual is steel. The inside dual wheels (steel) may be used at any wheel position.

Do not use the rear aluminum wheels on the front. Avoid using two aluminum wheels together on the rear as this may damage the outside surface of the wheel.

If a wheel gets damaged or needs replacement, please see your dealer. Replacement wheels and lug nuts should match original equipment specifications. *Your warranty coverage may be affected if any replacement wheel or lug nut does not match original equipment specifications.*

See the **Chassis Operator's/Owner's Guide/Manual** for care and maintenance recommendations for the aluminum wheels and lug nuts.

### **BODY UNDERCOATING**

An undercoating material has been applied to certain chassis and underbody components. This undercoating will help protect these components from the effects of weather, road deicing compounds, or other road debris or conditions. All areas of the underbody and chassis have not been undercoated. This is in keeping with good engineering practice and the requirements of the chassis manufacturers.

### **MAINTENANCE CHART**

For your convenience, a maintenance chart is included in Section 29 of this manual. Options and accessories usually have their own owner/user manuals that often contain added maintenance instructions. See the **Owner's Information Package**. Consult these manuals as required.

The hazard and possibility of fire exists in all areas of life, and the recreational life-style is no exception. Your motor home is a complex machine made up of many materials — some of them flammable. But like most hazards, the possibility of fire can be minimized, if not totally eliminated, by recognizing the danger and practicing common sense safety and maintenance habits.

The fire extinguisher furnished with your motor home is rated for Class B (diesel fuel, gasoline, grease, flammable liquids) and Class C (electrical) fires since these are the most common types of fires in vehicles. Read the instructions on the fire extinguisher. Know where it is located and how and when to use it.

Fire extinguishers are pressurized, mechanical devices. They must be handled with care and treated with respect. They must be maintained as outlined in any maintenance instructions provided with the device so they are ready to operate properly and safely. Parts or internal chemicals may deteriorate in time and need replacement. Always follow maintenance and recharging instructions provided by the fire extinguisher manufacturer.

## **FIRE SAFETY PRECAUTIONS**

Explosive fuel clouds may be present at fuel filling stations.

### **WARNING**

**Before refueling (either diesel or LPG) be sure to turn off all pilot flames, their ignitors, and appliances in your motor home. Turning off the propane at the tank is insufficient. Pilotless appliances may still spark or pilot flames may not extinguish immediately.**

## FIRE SAFETY

---

Instruct occupants on what to do in case of fire, and hold fire drills periodically.

Maintain proper charge in the fire extinguisher.

If you experience a fire while traveling, MAINTAIN CONTROL OF THE VEHICLE UNTIL YOU CAN SAFELY STOP. EVACUATE THE VEHICLE AS QUICKLY AND SAFELY AS POSSIBLE.

If you experience a fire while camped, EVACUATE THE VEHICLE AS QUICKLY AND SAFELY AS POSSIBLE.

Consider the cause and severity of the fire and risk involved before trying to put it out. If the fire is major or is fuel-fed, move away from the side of the LP gas tank, stand clear of the vehicle and wait for emergency assistance.

If your motor home is damaged by fire, do not drive or live in it until you have had it thoroughly examined and repaired.

## **SMOKE DETECTOR**

A battery-powered smoke detector is mounted on the ceiling in the living/cooking area of your motor home. Please read the smoke detector operating instructions for details on testing and caring for this important safety device.

Test the smoke detector after the motor home has been in storage, before each trip, and at least once a week during use.

The smoke detector should never be disabled due to nuisance or false alarm from cooking smoke, a dusty furnace, etc. Ventilate your motor home with fresh air and the alarm will shut off. **DO NOT DISCONNECT OR REMOVE THE SMOKE ALARM BATTERY.**

- Replace the battery once a year or immediately when the low battery "beep" signal sounds.

If the smoke detector fails to operate with new batteries, replace it with a new unit, available through an authorized Fleetwood Service Center.

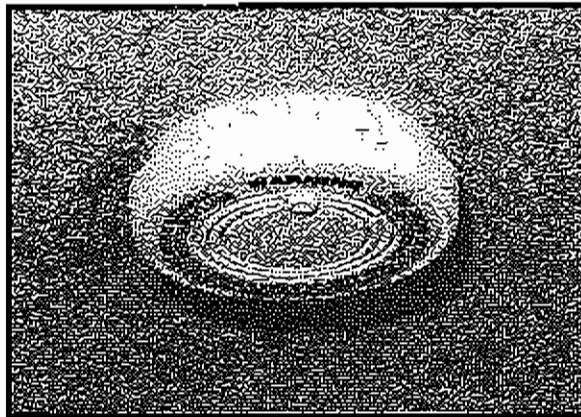

*Smoke Detector*

This page intentionally left blank.









**This page intentionally left blank.**

## **FRESH WATER SYSTEM**

The fresh water system allows flexibility in the sources of your fresh water, and in how you sanitize and winterize the system.

A system of valves and inlets allows you to configure the system for your circumstances. You can enjoy fresh water from either the on-board storage tank, with the system pressurized by the 12-volt water pump, or from an externally pressurized source, such as a park or campground water system. An externally pressurized water system is also known as "city water." Instructions in this manual will use the term "city water" to mean any pressurized source of water that is connected by a garden-type hose to the city water inlet.

### **CAUTION**

**Since water pressures at campgrounds and houses vary, an in-line pressure regulator is installed in the water supply inlet. Do not bypass this regulator.**

### ***Connecting Your Motor Home to City Water***

You will usually connect to city water when you set up at a campground or other facility that provides water hook-ups. These hook-ups typically use a standard garden hose fitting and valve, similar to an outdoor utility faucet at your home. You can also fill your on-board water tank from the city water connection.

## FRESH WATER SYSTEM

---

### To Connect to City Water Without Filling the On-board Tank

*(See the illustrations)*

1. Open the plumbing utility compartment door. The city water inlet is in this compartment. This inlet is a female garden hose fitting with a one-way check valve.
2. Connect one end of a potable water supply hose to the park or campground city water supply outlet, which will be a male garden hose fitting, similar to your garden hose valve at home. "Potable water" hoses are available at RV supply stores.
3. Turn the city water supply outlet valve ON and let it run for a few seconds to clear the line and hose. Turn the outlet valve OFF.
4. In the plumbing utility compartment, turn the **WATER TANK BYPASS** valve, the **COLD WATER DRAIN** valve, and the **HOT WATER DRAIN** to the right (clockwise) to close them, if necessary.
5. On Model WF and VS, turn **VALVE 2** vertical and **VALVE 1** horizontal. On Model AF, turn **VALVE 2** horizontal and turn the handle on **VALVE 1** toward the front of the vehicle.
6. Attach the free end of the city water supply hose to the city water inlet fitting. Tighten securely.
7. Turn the city water supply valve ON. The system is now pressurized by the city water supply. Water is available at the exterior utility washdown faucet and all interior faucets.
8. Open each faucet in the galley and bathroom. After any sputtering stops and water flows freely, close the faucet.

As long as you are connected to a city water supply, you have pressurized water at all faucets. You do not need to run the water pump. With the valves set this way, the water pump is isolated from the system.

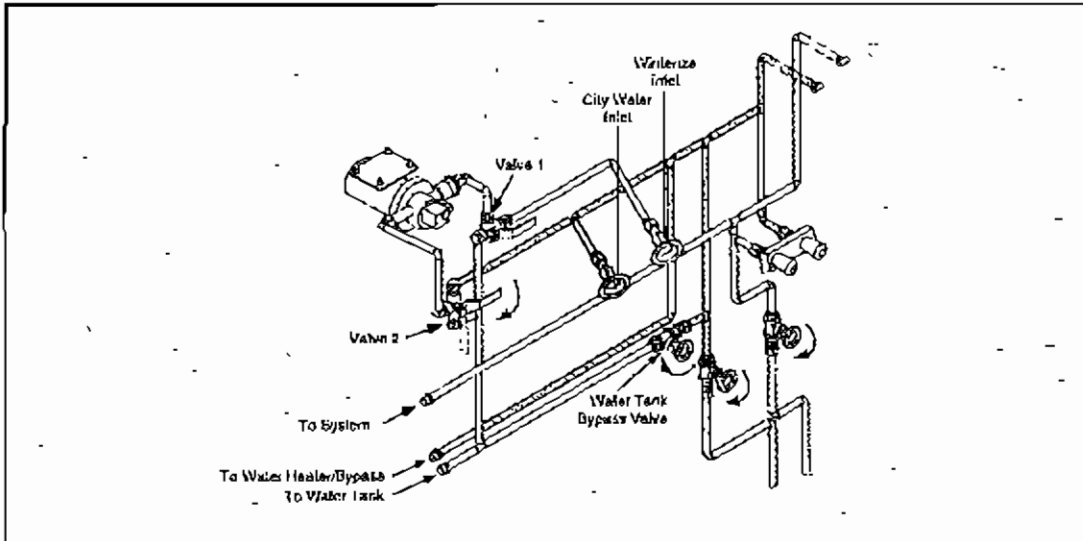

*Connecting to City Water – Water Tank Bypass*

### **Filling The Fresh Water Tank on Models 40VS, 40DS, 37RS:**

Before disconnecting the city water system, you may want to fill the fresh water tank. With the system connected as outlined above, just turn the **WATER TANK BYPASS** valve to the left (counterclockwise) to open it. Water will now flow into the tank.

Monitor the filling of the tank continually. The flow and pressure at some park and city water supplies could damage the tank if left unattended.

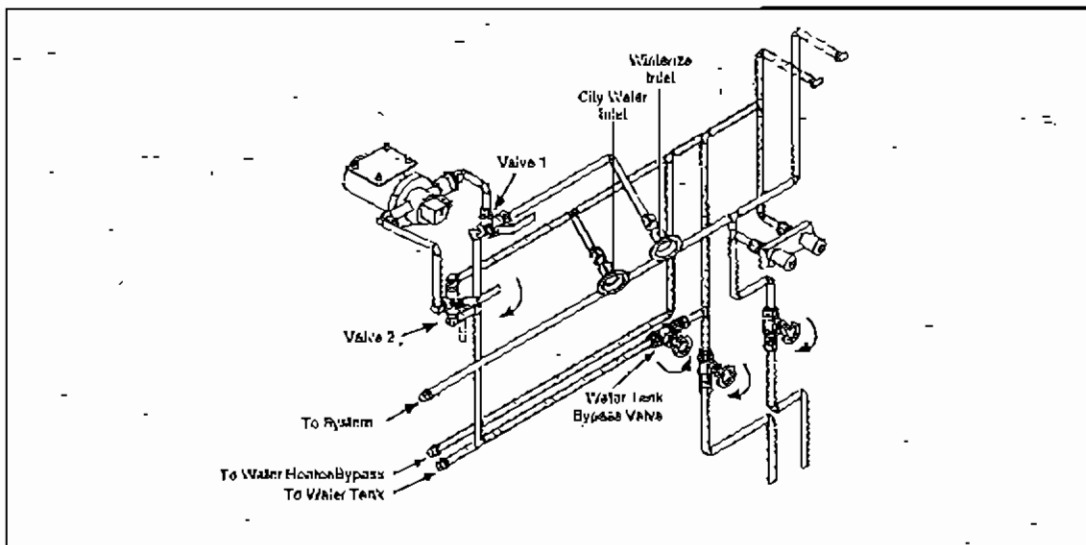

*Filling the Water Tank*

## FRESH WATER SYSTEM

---

### CAUTION

**Overfilling the fresh water tank from a pressurized source will cause serious damage to the water tank components or structural damage. Monitor water tank filling continually.**

Check the monitor panel often to determine when the tank is full. If water is flowing from the air/overflow vent, your tank is overfilled. Turn the city water supply valve OFF to stop filling. Turn the **WATER TANK BYPASS** valve to the right (clockwise) to close it.

You can now disconnect and store the city water supply hose.

### **GRAVITY FILL ON MODEL 37RS**

The external gravity fill is located on the exterior of the motor home in front of and above the Utility Water Compartment. The on-board water tank can be filled here also. To fill the fresh water tank, remove the cap and fill the tank using a potable water hose.

– Check the monitor panel often to determine if the tank is full. If water is flowing from the top vent, your tank is full. Stop filling.

### **SANITIZING THE FRESH WATER SYSTEM**

Sanitize the fresh water tank and piping approximately every three months, and whenever the motor home sits for a prolonged period. This will discourage the growth of bacteria and other organisms that can contaminate the water supply.

Sanitizing or winterizing the fresh water system requires four major steps:

- Getting the sanitize/winterize solution into the water tank
- Filling the water tank with water
- Pumping the solution through the system
- Draining/flushing the system

The procedure is the same for both sanitizing and winterizing, although the solution used is different. To winterize, you will need an approved RV water system antifreeze. To sanitize, prepare the following solution:

1/4-cup household liquid chlorine bleach (5% sodium hypochlorite) to one gallon of water for each 15 gallons of tank capacity. For a 100-gallon tank, 6<sup>2</sup>/<sub>3</sub> gallons of solution is required (the total amount of chlorine bleach for a 100-gallon tank is 1<sup>2</sup>/<sub>3</sub> cups.)

To sanitize/winterize Models 40VS and 40DS follow these steps:

**NOTE: To winterize, perform steps 1-7, 13-16, 19, 21, and 22 only.**

1. Prepare the required solution (either the chlorine solution or an antifreeze product) and have it standing by at the water utility compartment.
2. Close all drain valves and faucets.
3. Connect a length of garden-type hose to the **WINTERIZE** water inlet in the utility compartment. Put the other end of the hose into the container of solution.
4. Turn **VALVE 2** and **VALVE 1** handles vertical.

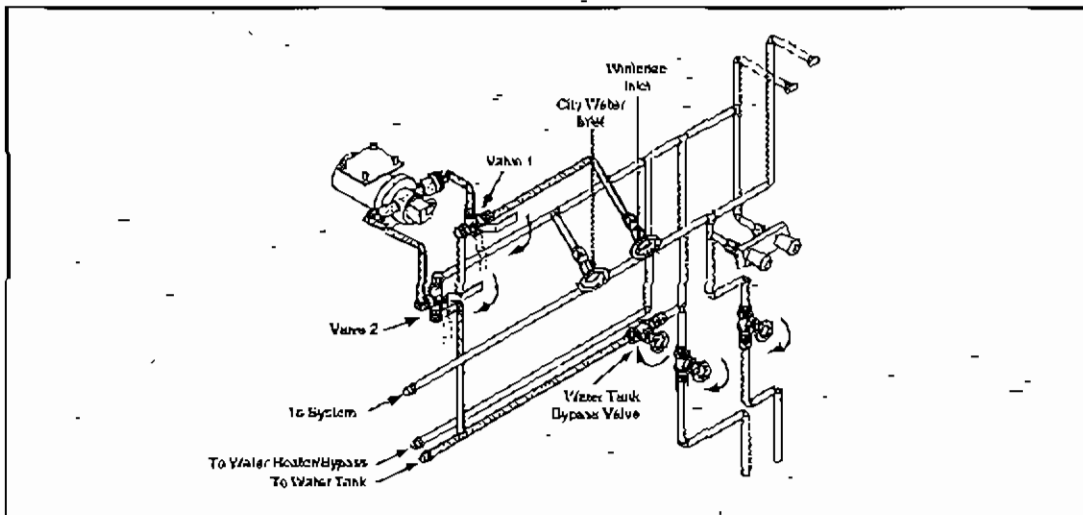

Sanitizing/Winterizing – Part 1  
Getting the Solution into the Water Tank

## FRESH WATER SYSTEM

5. Be sure 12-volt DC power is available, and turn the water pump ON. The pump will draw the solution and pump it into the water tank. Pump all the solution into the tank.
6. Turn water pump OFF.
7. Disconnect the hose from the **WINTERIZE** water inlet.
8. Turn **VALVE 1** handle horizontal.
9. Connect the potable water hose (the same one used to connect to an external water supply) to the **CITY WATER** inlet and an external water supply valve.

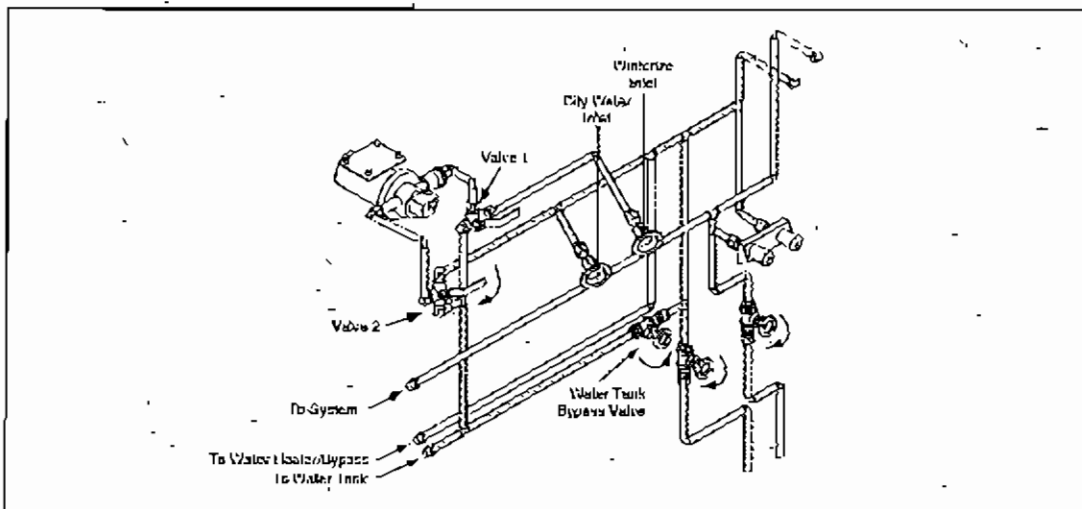

*Sanitizing/Winterizing – Part 2  
Filling the Water Tank with Water*

10. Turn the **TANK BYPASS** valve to the left (counter-clockwise) to open it.
11. Turn the water supply valve ON to fill the water tank. Monitor the tank filling continuously.
12. When the tank is full, turn off the water supply valve.



13. Turn the **TANK BYPASS** valve to the right (clockwise) to close it.
14. On all models, turn **VALVE 2** to horizontal.

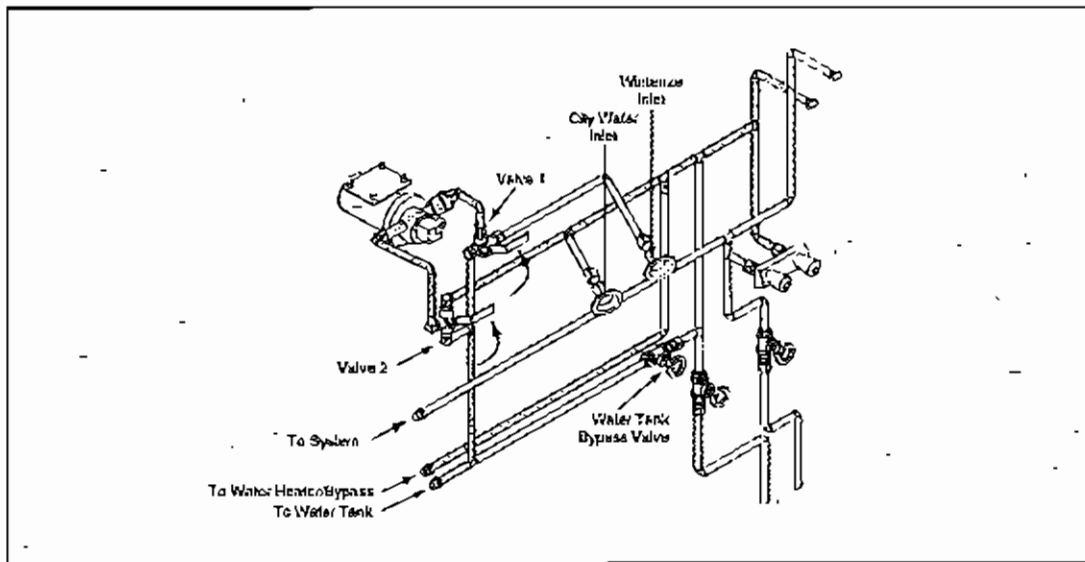

*Sanitizing/Winterizing – Part 3  
Pumping the Solution Through the System*

15. Turn the water pump ON.
16. Open all faucets individually until water flows steadily, then turn OFF. This will purge air from the lines.
17. Open the **TANK BYPASS** valve.
18. Turn the water supply ON and top up the water tank.
19. Let the solution set for three hours (sanitize only). If winterizing, the solution will remain in the system during freezing temperatures.
20. Drain the entire system by opening all drain valves, faucets, and tank drain valves.

## FRESH WATER SYSTEM

---

21. When the system is completely drained, repeat steps 9 through 16 to flush the system with fresh water. Be sure to run water through each faucet for several minutes to thoroughly flush out the solution.
22. Fill the water tank, if desired. The system is now ready to use.

### **To sanitize/winterize Model 37RS follow these steps:**

1. Close all drain valves and faucets.
2. Pour the solution into the external gravity fill.
3. Fill the fresh water tank.
4. Be sure 12-volt DC power is available, and turn the water pumps **ON**.
5. Open all faucets individually until water flows steadily, then turn **OFF**. This will purge air from the lines.
6. Let the solution stand in the water system for three hours.
7. Drain the entire system by opening all drain valves, faucets, and tank drain valve.
8. When the system is completely drained, flush the system with fresh water. Be sure to run water through each faucet for several minutes to thoroughly flush out the solution.
9. After you stop flushing the system, close the fresh water tank drain valve, system drain valves, and faucets.
10. Fill the fresh water tank if desired. The system is now ready to use.

---

## **THE WATER PUMP**

The on-board fresh water system is pressurized by a self-priming, 12-volt DC pump. The pump operates automatically when the pump power switch is ON and a faucet is opened. When the faucets are closed, the pump shuts off. At free flow, the pump draws approximately 7 to 7½ amps, and can run dry for extended periods without damage. A 15-amp fuse in the panel board (located at the foot of the bed) protects the water pump/water heater circuit. See "ELECTRICAL SYSTEMS."

Turn the pump master switch ON to pressurize the system. When a faucet is opened after the initial filling of the tank, the water may sputter for a few seconds. This is normal and is not cause for concern. The water flow will stabilize when all air is bled from the water lines.

## **WATER FILTER**

Dirt, mineral scale, and organic matter are filtered out of the fresh water system by an in-line water filter on the inlet side of the water pump. If you suspect a clogged filter, it is easily removed and cleaned.

Inspect the filter after the first 90 days of use, clean if necessary, and inspect annually thereafter.

1. Unscrew the water line at the inlet end of the filter.
2. Pull the water line off the filter.
3. Unscrew the filter from the water pump.
4. Turn each end of the filter and pull apart.
5. Flush out and clean screen.
6. Reverse procedure to install.
7. Operate the water pump and check for leaks.

## FRESH WATER SYSTEM

---

### **TROUBLESHOOTING THE FRESH WATER SYSTEM**

Water system problems usually fall into two categories; system problems, and problems caused by neglect. System problems are usually the result of road vibration and campsite water pressure variations. Problems of neglect usually stem from failure to clean filters, improper winterization, and poor battery maintenance. Most water system problems can be avoided by conscientious maintenance.

### **LEAKS**

Vibration, flexing and twisting while traveling can work pipe fittings loose. Check all plumbing for leaks at least once a year. If the water pump runs when a faucet is not open, check for a leak. Be sure the tank drain valves are tightly closed. Leaks occur most often around threaded fittings. If necessary, tighten or clean and tighten the fittings. Do not overtighten fittings. Connections at galley and lavy fixtures should not be tightened with a wrench. They will normally seal with hand-tightening. If a leak persists at one of the fittings, disconnect it completely and check for mineral deposits or other foreign matter at the seating surfaces. Clean the surfaces thoroughly and reinstall the fitting.

Connections at the water tank, pump and valves are made with special clamps. They can be replaced with standard aircraft type hose clamps.

To help reduce leaks caused by freezing damage, properly winterize the plumbing system. See "STORAGE" chapter of this manual. Freezing damage is usually extensive and may include a burst water tank, split piping, and a damaged water pump, toilet, and water heater. If you experience this type of damage, repairs can best be made by an authorized Fleetwood dealer.

### **EXTERIOR SHOWER**

A shower fixture is located in the plumbing utility compartment. The water pump must be ON or city water pressure must be available for the shower to operate.

*NOTE: The Hot and Cold knobs on the exterior shower fixture must be turned OFF when not in use to prevent uneven water temperatures at galley, lavy and shower fixtures.*

## WATER FILTER SYSTEM

Water filter systems help provide consistent drinking water quality as you travel. A special filter is part of this system. The filter cartridge is located in the cabinet under the galley sink. Your Owner's Information Package contains detailed operating and maintenance instructions concerning this system.

Please note that the special faucet at the galley and the ice maker are the only outlets for the filtered water. Although filtered water is not available at the standard galley and lavatory outlets, the water available at these outlets is filtered by the water pump filter. Note also that this system is not designed for or effective in removing or neutralizing bacterial contaminants.

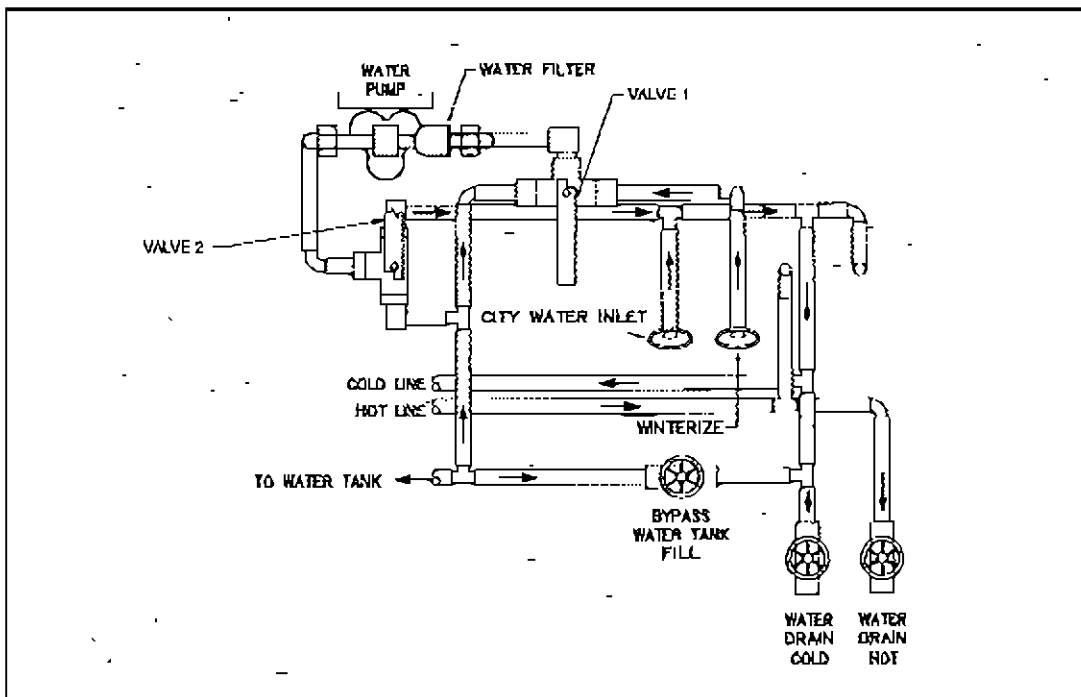

*Water Tank Fill Valves and Plumbing for Models 40DS and 40VS*

This page intentionally left blank.

---

See the **Chassis Operator's/Owner's Guide/Manual** for diesel fuel recommendations. The generator engine runs on the same fuel as the chassis. Consult the generator operating instructions for special cautions about maintenance with different types of fuels.

## **FUEL FILL**

The dual fuel filler caps are located behind doors just to the rear and above the front wheels. The fill pipes fill the same centrally located fuel tank.

### **WARNING**

When removing the fuel fill cap, rotate slowly only far enough to allow any built-up pressure to release. After "hissing" sound stops, complete the removal of the cap.

### **CAUTION**

The fuel pumps at truck stops supply diesel fuel at a high rate of flow. Use caution when filling to avoid spilling fuel.

## FUEL SYSTEM

---

To protect the fuel system from excessive pressure or vacuum, or from sudden release of pressure, replace lost or damaged caps with caps of the same design which are available through your Fleetwood motor home dealer.

Clean up fuel spills immediately. Raw fuel spilled on the motor home could damage the exterior finish, and is a serious fire hazard.

### **FUEL RECOMMENDATIONS**

#### **WARNING**

**Do not mix gasoline or alcohol with diesel fuel. This mixture can cause an explosion.**

Cummins (the engine manufacturer) recommends the use of ASTM No. 2 diesel fuel. At operating temperatures below 32°, acceptable performance can be obtained by using blends of No. 2 and No. 1 diesel fuels. The use of lighter fuels can reduce fuel economy.



The furnaces are forced-air units fueled by LP gas. All furnaces are equipped with wall thermostats for individual temperature settings.

The furnace will not operate properly if your stored personal items block the free flow of air at the registers or the return air to the furnace. Storage under cabinets should be done carefully so as to not crush or damage the furnace ducting.

Smoke and fumes created as a result of burning off residual manufacturing compounds are sometimes present the first time the furnace is used. This is normal; however, the initial light off should be done with windows and doors open and be of adequate duration to completely burn off the residue.

## WARNING

Portable fuel-burning appliances are not safe for heating inside the motor home. Asphyxiation or carbon monoxide poisoning can occur.

## FURNACE FILTER REPLACEMENT

The furnace filter is installed in a wood filter box. On Model 37RS it is located under the refrigerator and on Model 40DS under the range/oven. On model 40VS it is located under the washer/dryer cabinet.

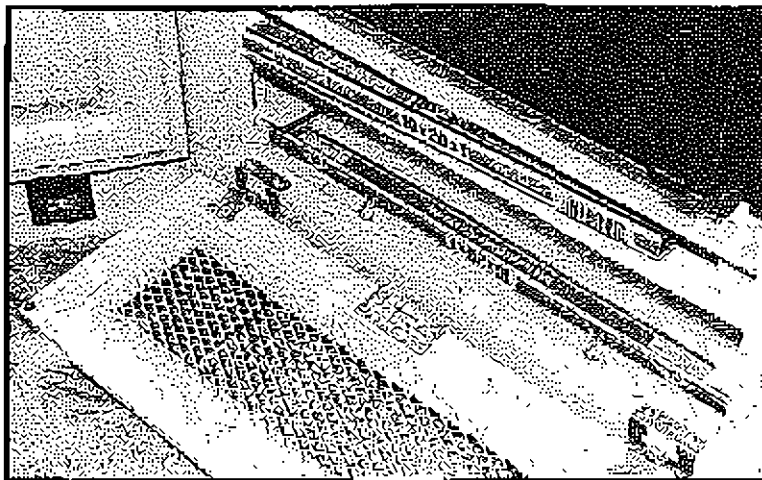

*Furnace Filter Replacement*

## FURNACE(S)

---

Generally, replace the filter after 90 days of furnace use. The air quality will determine how often the filter should be changed. In dirty or high humidity/high dust conditions, the filter may require more frequent changing. In these conditions, check the filter weekly during furnace use. Filters can be purchased through your local hardware store.

To remove the filter:

1. Turn the retainer tabs to clear the filter frame.
2. Pull filter straight out.

To install a new filter:

1. Remove old filter.
2. Remove new filter from storage box directly above the filter box.
3. Slide new filter into filter box. Be sure air flow arrows point downward.
4. Turn retainers to secure filter.

Your motor home is equipped with a diesel-powered generator which will provide complete electrical self-containment when regular public utility AC power is unavailable. Controls are on the instrument panel, and on the generator.

With the generator operating, power is available at all of the 120-volt AC power outlets in the motor home, just as if the power cord were connected to an external source. The generator is also connected to the power converter, thus supplying 12-volt DC power as well. The generator circuit breakers must be ON for the generator to supply power to the motor home. The generator circuit breakers are located on the generator.

## **GENERATOR FUEL SUPPLY**

Fuel for the generator is taken from the main fuel tank through a special feeder tube which is higher in the tank than the feeder tube to the motor home engine. This arrangement prevents the generator from running the motor home fuel tank dry.

## **GENERATOR OPERATION**

*NOTE: Refer to the generator operating instructions provided in your **Owner's Information Package** for information before starting the generator. Do not start the generator unit with a heavy power load. Always wait at least three minutes after starting generator before turning on (or plugging in) heavy electrical loads, such as the roof air conditioner.*

### **To start the generator:**

1. Push the control switch to its START position and hold it there while the status indicator light blinks rapidly indicating preheat. Let go when the light comes on continuously, indicating that the generator is running and that the starter has been disconnected. (Depending on how cold it is, preheat can take up to 15 seconds, extending the time that the light blinks.)

# GENERATOR

---

## CAUTION

- Excessive cranking can overheat and damage the starter motor. Do not crank for more than 30 seconds at a time. Wait at least 2 minutes before trying again.
- 2. See the Troubleshooting Guide in Onan's RV Genset Operator's Manual located in the Owner's Information Package if the generator does not start after several tries.

### To stop the generator:

1. Run the generator at no load for a few minutes to allow the engine to cool down and then push the control switch briefly to its STOP position.

## **GENERATOR OPERATING SAFETY PRECAUTIONS**

Read and understand the generator operating, maintenance and safety instructions furnished in your **Owner's Information Package**.

Do not smoke or use an open flame near the generator unit or fuel tank.

## WARNING

Do not place flammable material or store any other materials in the generator compartment.

## WARNING

Do not block the generator ventilating air inlets or outlets. The engine requires a constant supply of cooling air. Restricted ventilating air inlets or outlets can cause engine failure or fire from engine overheating.

Do not use generator ventilating air for heating any interior living space. Ventilating air can contain high concentrations of lethal gases.

Check engine fuel lines often. Fuel leakage in or around the engine compartment is an extreme fire hazard. Do not use the generator until fuel leaks are repaired.

## WARNING

**EXHAUST GASES ARE DEADLY.** Inspect the generator exhaust system thoroughly before starting the generator engine. Do not block the tail pipe or situate the motor home in a place where the exhaust gases have any possibility of accumulating either outside, underneath, or inside your vehicle or any nearby vehicles. Outside air movements can carry exhaust gases inside the vehicle through windows or other openings remote from the generator exhaust. Operate the generator only when safe dispersion of exhaust gases can be assured, and monitor outside conditions to be sure that exhaust gases continue to be dispersed safely.

Be aware of exhaust gas (carbon monoxide) poisoning symptoms. Refer to "CARBON MONOXIDE SAFETY PRECAUTIONS" chapter.

## WARNING

**DO NOT UNDER ANY CIRCUMSTANCES OPERATE THE GENERATOR WHILE SLEEPING.** You would not be able to monitor outside conditions to assure that generator exhaust does not enter the interior, and you would not be alert to exhaust odors or symptoms of carbon monoxide poisoning.

Check the generator exhaust system after every 8 hours of operation and whenever the system may have been damaged, and repair any leaks or obstructions before further operation. Disconnect the battery before performing any maintenance on the generator. Allow the generator to cool before performing any maintenance.

# GENERATOR

---

## WARNING

Do not operate the generator when parked in or near high grass or brush. Exhaust heat may cause a fire.

## WARNING

Do not modify the generator installation or exhaust system in any way.

Do not use the generator as an emergency power source to a general residential or industrial utility line. This is illegal and may cause shock or electrocution to power line utility personnel attempting to repair power lines.

## ***GENERATOR COOLING SYSTEM***

The generator is liquid cooled. The cooling system includes a radiator, cooling fan, water pump, a coolant reservoir/recovery container, and is similar to the automotive engine cooling system.

Check and maintain the coolant level at the coolant recovery container located on the front of the generator.

## CAUTION

Do not check the coolant system at the radiator cap when the generator is hot. Check the system at the COOLANT RECOVERY CONTAINER only.

## ***GENERATOR MAINTENANCE***

Refer to the generator manufacturer's information in the **Owner's Information Package** for details on generator operation and maintenance.

---

The materials used inside your motor home have been selected for durability and comfort. With reasonable care, these materials will stand up under years of recreational living. The "INTERIOR MAINTENANCE" chapter in this manual outlines care requirements for the various upholstery fabrics, floor, cabinet, and wall finishes.

## ***EFFECTS OF LONG-TERM OCCUPANCY***

Your motor home was designed primarily for recreational use and short term occupancy. If you intend to occupy the motor home for an extended period, you should understand that the additional wear will cause premature deterioration of structure, interior finishes, fabrics, carpeting, drapes, appliances and fixtures. You should also be prepared to deal with condensation and the humid conditions that may be encountered. The relatively small volume, and tight, compact construction of modern recreational vehicles mean that normal living activities of even a few occupants will lead to rapid saturation of the air, and the appearance of visible moisture, especially in cold weather.

Just as moisture collects on the outside of a glass of cold water during humid weather, moisture can condense on the inside surfaces of your motor home during use in cold weather when humidity of the interior air is high.

Water vapor will condense on the inside of the windows and walls as moisture, or in cold weather as frost or ice. It may also condense out of sight within the walls or the ceiling where it will manifest itself as stained panels. Appearance of these conditions indicates a condensation problem. When you recognize the signs of excessive moisture and condensation, you should take action to minimize their effects.

## INTERIOR AND FURNISHINGS

---

### ***VENTILATION AND CONTROLLING CONDENSATION***

You can reduce or eliminate interior condensation during cold weather by taking the following steps:

#### ***Ventilate with Outside Air***

Partially open one or more roof vents and one or more windows to provide controlled circulation of outside air into the interior. While this ventilation will increase furnace heating load, it will greatly reduce, or eliminate, condensation. Even when it is raining or snowing, outside air will be far drier than interior air and will effectively reduce condensation.

#### ***Reduce Moisture Released Inside the Motor Home***

Run the range vent fan when cooking and the bath vent fan (or open the bath vent) when bathing to carry water vapor out of the motor home. Avoid making steam from excessive boiling or use of hot water. Remove water or snow from shoes before entering to avoid soaking the carpet. Avoid drying overcoats or other clothes inside the motor home.

### **CAUTION**

**DO NOT HEAT THE MOTOR HOME INTERIOR WITH THE RANGE OR OVEN. Open flames add moisture to the interior air. Do not use an air humidifier inside the motor home. Water put into the air by the humidifier will increase condensation.**

#### ***Ventilate Closets and Cabinets***

During prolonged use in very cold weather, leave cabinet and closet doors partially open to warm and ventilate the interiors of storage compartments built against exterior walls. The air flow will warm the exterior wall surface, reducing or eliminating condensation and preventing possible ice formation.



## ***Install A Dehumidifier Appliance***

During prolonged, continuous use, a dehumidifying appliance may be more comfortable and effective in removing excess moisture from the interior air. While use of a dehumidifier is not a "cure-all", and ventilation, and moisture reduction continue to be important, operation of the dehumidifier will reduce the amount of outside air needed for ventilation. Heating load on the furnace will be reduced, and the interior will be less drafty.

## ***ATTACHING ACCESSORIES TO YOUR MOTOR HOME***

The walls in your motor home are constructed with Vacu-Bond lamination technology. Structural members are located specifically to mount and attach factory-installed components and accessories, and may not be located to support after-market accessories not specifically designed for use on or in your motor home.

Please consult with your dealer before attempting to install or mount accessories on the sidewalls of your motor home. Holes drilled in the sidewall may cause damage, and may affect portions of your warranty coverage.

If you add accessories to the exterior of your motor home, the attachments must be inspected and sealed the same as factory installed accessories. See the "Sealant Renewal" section of the "EXTERIOR MAINTENANCE" chapter of this manual.

## ***DINETTE CONVERSION***

*(Does not apply to free-standing dinette)*

To convert the dinette into a bed:

Unfasten and remove cushions.

Reach under the table, either remove leg or fold up under the table top.

Raise front portion of table several inches to disengage inserts from the wall supports.

## INTERIOR AND FURNISHINGS

---

Lower table top to the dinette frame to complete bed base.

Slide seat and back cushion into place over bed base.

### **SOFA/LOUNGE CONVERSION**

To convert a sofa/lounge into a bed:

Remove sofa bolsters.

Lift front of sofa frame up and out.

Push the back of the lounge back and down.

Push the seat belts through the space between the lounge back and seat.

To restore the sofa/lounge:

Pull the seat belts back up through the space between the lounge back and seat.

Lift the front edge of the sofa frame up, and push it back. The sofa back will come up. Push the sofa into position.

### **FOLDING DOORS/PRIVACY CURTAIN DIVIDERS**

The dividers allow you to separate areas in the motor home. They glide on nylon rollers and do not require lubrication. They are held closed by a catch. When the dividers are open for traveling, be sure to attach the hold back straps to keep them from sliding back and forth.

### **INTERIOR LIGHTING**

Both decorative and "utility" style 12-volt lighting fixtures may be used in your motor home.

For your convenience, some lights are operated from wall switches. Clean the lenses with soapy water.

---

## **OVERHEAD VENTS**

Overhead vents are located in the galley and bathroom areas for fresh air circulation and exhausting heat, odors and water vapor.

Turn the crank in the vent to open and adjust. Some vents may also be equipped with a 12-volt fan. A switch controls fan operation. Be sure to turn the fan OFF before closing the vent. Some motor homes may be equipped with optional vents using a 12-volt fan and a rain sensor. This feature automatically closes the vent in case of rain.

Close the vents or lower them before traveling to avoid damage from wind and low overhead clearances.

The vent may be cleaned from the top of the motor home. Use soapy water on the vent cover. The screens may be vacuumed or lightly brushed to remove accumulation of leaves or other debris.

Lubricate the gears and mechanism yearly with a light, water resistant grease.

## **FOLDING CHAIRS**

In some models, loose folding chairs are provided for your convenience. The chairs are stored in an interior rear storage compartment.

## **SUN VISORS**

The sun visors at the driver and passengers positions swing down and adjust to provide relief from glare and bright skies. The visors do not adjust to shade the side windows.

Swivel tension may be adjusted at the tension adjuster.

## INTERIOR AND FURNISHINGS

---

### **MINI-BLINDS**

To raise mini-blinds: Release bottom of blind from retainer. Pull straight down on cord and release at desired height. It is not necessary to pull the cord to one side or the other to secure blind.

**To lower mini-blind:** Pull straight down on the cord slightly, and move it about 45 degrees to either the left or right and lower the blind. Stop the blind in mid-travel by moving cord back to the straight down position. Re-attach the retainers when traveling.

**To adjust the angle:** Turn the adjusting rod either direction.

### **DAY/NIGHT SHADES**

These window shades are split into a "daytime" area and "nighttime" area.

To close the "daytime" shade, pull down on the lower handle. To open, pull up on this handle.

To close the "nighttime" shade, pull down on upper handle. To open, pull up on this handle.

---

## **UPHOLSTERY AND DRAPES**

The upholstery/decor items are made of flame-retardant material. To retain the flame retardant nature of these fabrics, dry clean only.

Frequent vacuuming or light brushing between cleanings will help prevent accumulation of dirt and grime. Use of water-based or detergent based cleaners may cause shrinking or other fabric damage. Water stains may become permanent.

### **WARNING**

Do not use lacquer thinner, nail polish remover, carbon tetrachloride, spot remover, gasoline, or naphtha for any cleaning purpose. These products may cause damage to the material being cleaned, and may be highly flammable or poisonous.

## **COUNTER TOPS**

### ***Corian® Top Care***

Since Corian® is a non-porous material, many food and household chemical stains wipe off with a sponge and soapy water. Stubborn stains like coffee, grape juice, ink and food coloring rub off with household cleanser.

## **WALLS AND CEILING PANELS**

The paneling and the ceiling of your motor home may be any of several finishes and textures. Never use harsh detergents or abrasive cleaners on walls or ceilings. Most surfaces will clean with a soft cloth moistened with mild liquid detergent in warm water. Do not use large amounts of water which could saturate the material.

## INTERIOR MAINTENANCE

---

### **FIBERGLASS BATHTUB AND SHOWER STALL**

Some cleaners attack the plastic causing it to discolor and become brittle. The following cleaners have been tested and approved when mixed with water: Distilled vinegar, mild dishwasher detergent, or liquid deodorizing cleaner. Avoid cleaners with any level of abrasives, acetone or MEK (methyl ethyl ketone).

### **FLOORS AND CARPETING**

Vacuum carpeting regularly, and clean it with a quality carpet cleaner.

### **TILE CARE**

To clean tile areas, use a clean sponge/mop with a mild detergent in hot water. Avoid abrasive cleaners.

The grout is non-staining and can be cleaned with a mild detergent in hot water.

Liquefied petroleum (LP) gas is available from approved storage tanks to operate your range, oven, furnace and water heater, and as an alternate energy source for the refrigerator. With proper handling precautions, LP gas is safe and provides modern conveniences wherever you travel. LP gas is stored as a liquid under pressure and vaporizes under the control of a pressure regulator.

A typical LP gas tank installation is illustrated below. Although specific details of the system may differ in your motor home, the major components and their relationships will be similar to those shown.

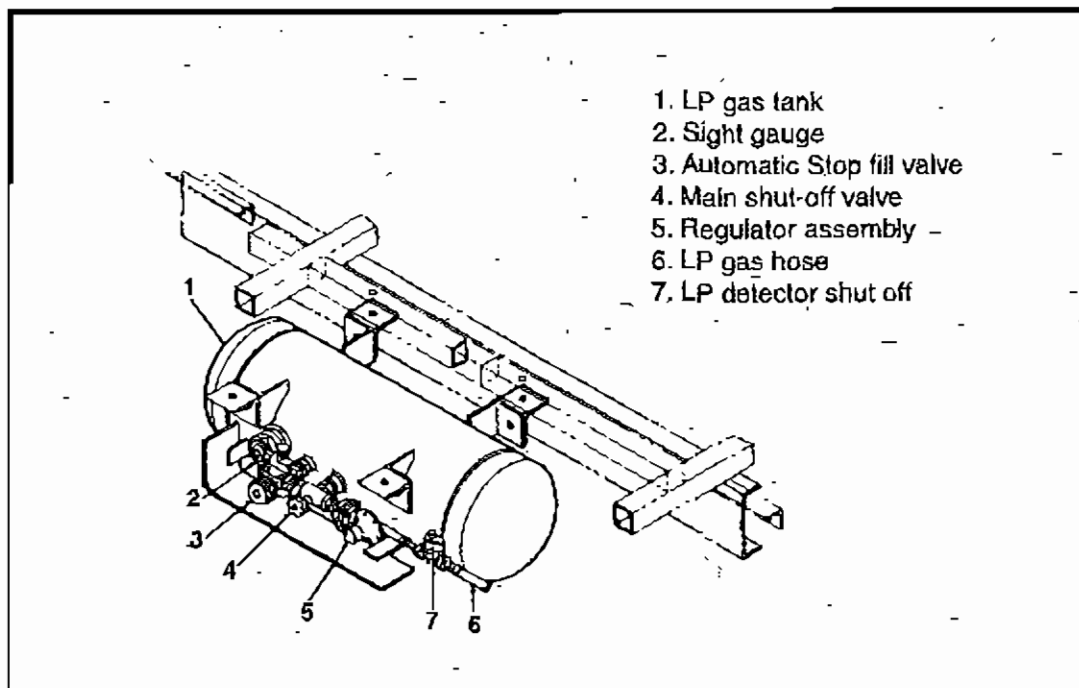

## WARNING

Do not block the vent openings in the LP gas system component compartment. These vents are required for proper ventilation of the LP gas system. Do not store materials in this compartment.

# LP GAS SYSTEM

---

## **LP GAS SAFETY PRECAUTIONS**

LP gas is a safe and reliable fuel. As with any other volatile and flammable material, common sense dictates that LP gas be handled and used with respect and caution. Because LP gas systems are so reliable, they are often taken for granted. Neglect can be a very dangerous habit. If the system is maintained regularly, you can expect almost trouble free operation.

### **WARNING**

**LP GAS IS FLAMMABLE AND POTENTIALLY EXPLOSIVE. USE PROPER HANDLING, LIGHTING AND VENTILATING PROCEDURES.**

1. The distinctive odor of LP gas indicates a leak. If you smell gas:

**DO NOT TOUCH ELECTRICAL SWITCHES.**

Extinguish all open flames, pilot lights and all smoking materials.

Shut off the gas supply at the tank valve(s) or gas supply connection.

Open the door and leave the area until the odor clears.

Have the gas system checked by a professional and the cause of the leak corrected before using the motor home again.

2. Inspect the entire LP gas system for leaks or damaged parts before each trip and before filling tank. See section on "LP Gas System Leak Checks."



3. Never check for leaks with an open flame. Use an approved leak detection solution or a non-ammoniated, non-chlorinated soap solution only. If the leak cannot be located, take the unit to an LP gas service representative.
4. Always be careful when drilling holes or fastening objects to the motor home. The gas supply lines could be punctured by a nail or screw.
5. Do not restrict access to LP tanks. In an emergency, the tank service valve must be easily identified and accessible. The tank compartment door must always be unlocked, and the LP label should be visible.
6. Do not carry or store filled or empty LP gas containers, including accessories such as gas barbecues, in your motor home. LP gas containers are equipped with a safety device that relieves excessive pressure by discharging gas to the atmosphere. Leaks can occur at valves and fittings. Always store LP tanks outside with the valves closed and plugged.
7. Do not use any LP gas tank other than the one furnished with your motor home without being sure that all connecting components are compatible.
8. Turn off LP gas main valve before filling LP gas tank or entering an LP gas bulk plant or motor fuel service station. Turn off all pilot lights and appliances individually before refueling of motor fuel tanks and/or LP gas containers. When not individually turned off, automatic ignition appliances may continue to spark when LP gas is turned off at the container.

# LP GAS SYSTEM

---

9. Do not fill LP gas containers to more than 80% capacity. Overfilling can result in uncontrolled gas flow which can cause fire and explosion. A properly filled container holds about 80% of its volume as liquid.
10. LP gas regulators must always be installed with the diaphragm vent facing downward. Make sure that the regulator vent faces downward and that the cover is kept in place to minimize vent blockage which could result in excessive gas pressure causing fire or explosion.
11. Do not use a wrench or pliers to close the tank shut-off valve. This valve is designed to be closed leak-tight by hand. If a tool is required to stop a leak, the valve probably needs repair or replacement.
12. If you do not have the special tools and training necessary, do not attempt to repair or modify LP gas system components.
13. Always think safety.

## **SYSTEM COMPONENTS**

### ***Hoses***

The hoses used in your LP gas system meet UL or CSA requirements, and are rated to withstand many times the pressures encountered in the system. Although they are designed for efficient and trouble free use, they can deteriorate from impurities in the air. Consequently, check the hoses for weather checking or other signs of deterioration every time you have the gas tank filled or serviced. When you replace hoses, be sure that replacements are properly rated and approved for RV use.

## ***LP Gas Regulator***

The regulator is the heart of the LP gas system. It reduces the tank pressure, which can vary from 250 psi to 7 psi, to a steady 6 ounces (11 inches of water column) to serve the appliances in the motor home. It does this in two stages for safety and efficiency.

Because the regulator is constantly “breathing”, it is equipped with a vent. It is very important that the vent stays clean and free from obstruction. Clogging from corrosion, dirt, insect nests or other debris is the most common cause of regulator malfunction. Even a small piece of material that finds its way into the vent can result in improper pressure in the system and possible damage to or failure of components. The regulator is mounted so that the vent is facing downward and is protected from water and dirt by a water-resistant cover. Be sure the cover is on at all times. If the vent becomes clogged, it can be cleaned with a toothbrush. If corrosion is evident, contact a qualified LP gas service technician for a replacement regulator.

### **WARNING**

**Do not attempt to adjust the regulator. It has been preset by the regulator manufacturer. If any adjustment is required, it must be made by a qualified LP gas service technician using special equipment.**

## ***USING LP GAS SYSTEM AT LOW TEMPERATURES***

Your LP gas system will function at low temperatures, provided the system components are kept at a temperature above the vapor point of the LP gas. Ask your LP gas supplier or your motor home dealer for information on product blends available in your area and the areas in which you will be traveling.

## LP GAS SYSTEM

The following chart shows the reduction in available BTU's/hour under various fill levels as the temperature drops:

%FULL + 20"	20 lb. Tank*				
	0°	-5°	-10°	-15°	
60%	36,000	18,000	12,750	8,500	4,250
50%	32,400	18,200	12,150	8,100	4,050
40%	28,800	14,400	11,400	7,600	3,800
30%	25,200	12,600	10,450	7,300	3,150
20%	21,600	10,800	8,100	5,400	2,700
10%	16,200	8,100	6,075	4,050	2,025

\*30 lb. Tank multiply x 1.40

The chart clearly shows how the availability of the gas is reduced at lower temperatures. With this in mind, keep your LP tank as full as possible during cold weather. Check the BTU/hr. rating plates on your LP gas appliances. This information will help manage your LP gas requirements efficiently.

LP gas systems can and do freeze up in very cold weather. It is a common misconception that the regulator or the gas itself freezes. Actually, it is moisture or water vapor that gets trapped in the system or absorbed by the gas that freezes and causes the problem. This ice can build up and partially or totally block the gas supply.

There are a number of things you can do to prevent freeze up:

1. Be sure the gas tank is totally moisture-free before it is filled. If you are not sure, have an LP service station inject an approved antifreeze or deicer into the tank.
2. Be sure the tank is not overfilled. This is also a safety consideration.

3. Have the gas tank purged by the LP gas service station if freeze up occurs.
4. Be sure you have the proper gas blend for your traveling area. If you have the proper gas blend, it is very unlikely that the gas is at fault.

If, despite precaution, you do experience freeze up, ask your LP gas supplier to service the tank or regulator as required.

## **FILLING LP GAS TANKS**

To fill the chassis-mounted storage tank, drive the vehicle to an LP gas supplier or a service station which sells LP gas. Do not attempt to fill the tank yourself.

### **WARNING**

Turn off LP gas main valve before filling LP gas tank or entering an LP gas bulk plant or motor fuel service station. Turn off all pilot lights and appliances individually before refueling of motor fuel tanks and/or LP gas containers. When not individually turned off, automatic ignition appliances may continue to spark when LP gas is turned off at the container.

### **WARNING**

Do not fill LP gas containers to more than 80% of capacity. Overfilling can result in uncontrolled gas flow which can cause fire and explosion. A properly filled container holds about 80% of its volume as liquid.

## LP GAS SYSTEM

---

### **LP GAS SYSTEM LEAK CHECKS**

In its natural state, LP gas is odorless. An additive, ethyl mercaptan, is added to the gas to help detect leaks. If you smell a garlic-like odor, there may be an LP gas leak. Obvious leak-sources are fittings, valves and couplings.

For your safety, check for leaks in your gas system each time the tank is filled and before each trip. Always check the system any time you detect a garlic-like odor. Listen for a sustained hiss or hum when you turn the gas on. This may indicate a leak.

The first time you have your LP tank filled, have the serviceman bleed a little LP gas out of the small outage valve (this also lets you check that the bottle is not overfilled) and note the odor for future reference. A small number of people cannot smell this odor; if you are one of these you must take extra care in checking for leaks, as well as whenever you use LP gas appliances.

To perform a leak check, swab a mixture of a non-ammoniated, non-chlorinated soap solution or an approved leak detection solution over each fitting, joint and connection in the system. Open the tank service valve. Inspect each joint. If even the smallest bubbles appear at any joint, this joint must be re-made. Refer repairs to an authorized Fleetwood service center or your LP gas service facility. Never attempt to repair gas piping without proper tools and know-how.

Potential trouble spots for leaks are areas where piping runs close to chassis and frame members. Look for chafes and cracks around pipe hangers. If you find defects in any LP gas system component, have it repaired or replaced before using the system.

As an added precaution, do a visual check of all exposed piping and fittings after you have arrived at a destination and before you use the LP gas system. Travel and road shocks may have caused damage to the system that you will need to repair before using the appliances.

## WARNING

Never check for leaks with an open flame. Do not check for leaks using ammoniated or chlorinated household type detergents. These can cause cracks to form on the metal tubing and brass fittings. If the leak cannot be located, take the unit to an LP gas service representative. Keep the tank valve closed and turn off all appliances if the unit is not being used.

## WARNING

Do not use pliers or a wrench to tighten valves. If a valve is not leak-tight when closed by hand, see an LP gas service representative.

## LP LEAK DETECTOR

An LP gas leak detector is located near the floor. The unit sounds an alarm alerting you to the presence of low levels of potentially dangerous LP gas that may have been released due to a gas leak. The unit also sounds an alarm when it senses LP or similar gases such as hair spray or cleaning solvent.

The detector is powered by the motor home and chassis 12-volt DC battery systems. A power switch is located on the panel. A green light on the detector front panel indicates that the detector has power.

Test the leak detector each time you relocate and use the motor home.

### Testing Procedure:

Hold a butane-fueled pocket lighter near the sensor.

Open the lighter valve without striking the flame. The leak detector should respond within a few seconds.

To reset the alarm, turn the detector OFF and back ON again.

Lightly fan the area around the detector to insure complete dispersion of the gas from the lighter, and to prevent another sounding of the alarm.

## LP GAS SYSTEM

---

A silence button allows you to temporarily quiet the alarm for 60 seconds after it has been set off or after testing.

If the alarm does not sound during a test or if the green indicator light is not visible, see your dealer or an authorized Fleetwood Service Center. There are no batteries or user serviceable parts inside the unit.

*NOTE: Remember to turn off the detector if you are not using your motor home. The detector draws enough current to discharge your battery.*

### **LIGHTING LP GAS APPLIANCES**

Detailed operating information for the LP gas appliances can be found in your **Owner's Information Package**. Please read and follow these instructions.

Air trapped in the gas lines may delay the initial lighting of any appliance. It could take several seconds or minutes for the gas to reach the appliance. To purge some of the air from the gas system, first light a burner on the range. The other appliances will then light more quickly.

We recommend lighting the pilot light at the range, if equipped, rather than individually lighting each burner. This will help prevent accidental leaks at the burner. Be sure the pilot light is extinguished while traveling.

The first time the furnace or oven is operated, paints and oils used in manufacture may generate some smoke and fumes. If this occurs, open doors and windows to air out the motor home. These materials should burn off after the first 15 to 20 minutes of appliance operation.

**Always follow the appliance manufacturers' lighting and operating instructions.**



## Start of Each Traveling Season

Lubricate power step mechanism	Inspect and test safety equipment: fire extinguisher, LP, carbon monoxide, and smoke detectors, and GFI receptacles.
Lubricate the stepwell cover mechanism (front entry door models only)	Service appliances and equipment: refrigerator, roof air conditioner, furnace, generator.
Lubricate TV antenna	Inspect generator exhaust system.
Check all exterior sealants, around windows, doors, sidewall seams, windshield, lamps, all exterior openings and roof components. Re-seal if necessary.	Inspect LPG system including leak check.
Inspect and clean fuel-fired appliance vents: water heater, refrigerator, furnace.	Sanitize fresh water tank.
	Clean drapes and interior fabrics.
	Check exterior lamp operation.

## Each Trip or Monthly

Wash exterior	Lubricate power step mechanism
Inspect LPG system including leak check	Check tire pressures

## Every 8 Hours

Inspect generator exhaust system

## Weekly

Inspect and clean fuel-fired appliance vents: water heater, refrigerator, furnace.	Inspect and test safety equipment: fire extinguisher, LP, carbon monoxide, and smoke detectors, GFI receptacles.
--	--

## Every 3 Months

Check all exterior sealants, around windows, doors, sidewall seams, windshield, lamps, all exterior openings and roof components. Re-seal if necessary.	Sanitize fresh water tank.
---	----------------------------

# MAINTENANCE CHART

## Every 6 Months

Lubricate TV antenna

Clean drapes and interior fabrics.

Check exterior lamp operation.

## Each Year

Lubricate and adjust exterior locks, hinges, and window mechanisms

Wax exterior

Inspect and clean fuel-fired appliance vents: water heater, refrigerator, furnace.

## End of the Traveling Season

Lubricate power step mechanism

Lubricate the stepwell cover mechanism (front entry door models only)

Inspect and clean fuel-fired appliance vents: water heater, refrigerator, furnace.

Lubricate TV antenna

Inspect generator exhaust system

Check all exterior sealants, around windows, doors, sidewall seams, windshield, lamps, all exterior openings and roof components. Re-seal if necessary.

Inspect LPG system including leak check

## At Specified Mileage or Interval

(See Owner's Information Package)

Service appliances and equipment: refrigerator, roof air conditioner, furnace, generator.

## At Specified Mileage for Heavy Duty Service

(See Chassis Operator's/Owner's Guide/Manual(s))

Chassis

# MONITOR PANEL

The fluid monitor panel allows you to conveniently check the approximate levels in the fresh, gray, black water holding tanks, and LP tank. The electrical monitor panel allows checks of the 12-volt motor home battery system and the charging status of the solar charging system.

Monitor panel controls and display panels are located in the overhead cabinet and in the exterior utility compartment.

## FLUID MONITOR PANEL

Electrical probes installed in the tanks measure the levels at various points in the tanks.

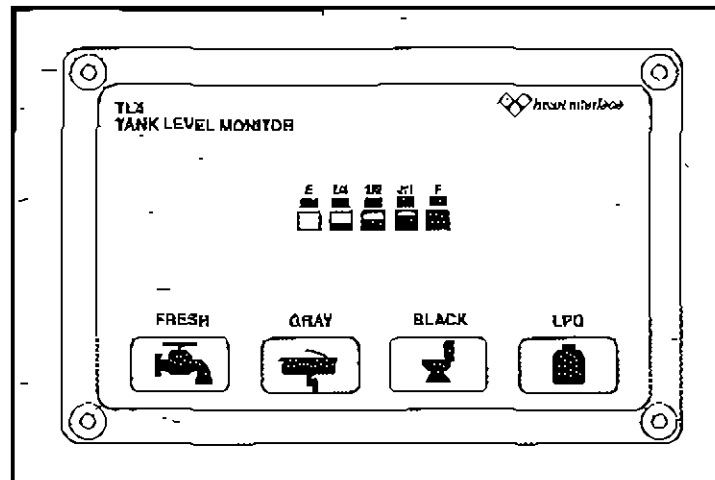

*Fluid Monitor Panel*

To check tank levels:

Press and hold the tank switch you wish to read the fluid level in; **FRESH** (potable water), **GRAY** (sinks, shower, and washing machine), **BLACK** (toilet), **LPG** (liquefied petroleum gas).

The **E** or empty indicator light will always be lit when the rocker switches are depressed. If the tank is full, all lights will be on. Lights are sequential, and indicate the level in approximately  $\frac{1}{4}$ -tank increments. If the tank selected is approximately  $\frac{1}{2}$ -full, for example, lights **E**, **1/4** and **1/2** will be on.

## MONITOR PANEL

---

Erroneous tank level indications can be caused by:

**Water with low mineral content.** The level is measured by a very low level electrical signal traveling through the liquid. Some water may not conduct the signal properly. This condition may be infrequent, but can exist. Check the panel reading when the fresh water tank is filled.

**Material trapped on the sides of the holding tanks** may give a full reading when the tank is actually empty.

*NOTE: If the sensor probes mounted in the tanks get coated with grease, the monitor panel may indicate falsely or not at all. Avoid pouring grease, oils or similar substances down drains or the toilet. If this is unavoidable, the holding tank(s) should be washed out with a soapy water solution. See your dealer for additional information.*

### **LINK 1000 INSTRUMENTATION AND CONTROL PANEL**

The Link 1000 is an instrumentation and control panel designed for use with the Source Manager Series Inverter/Chargers operated with a single house battery bank.

# MONITOR PANEL

## Link 1000 Quick Start Basic Operations

This **Quick Start** is *not* intended to replace reading the *Link 1000* manual. Please take time to read and understand the manual in order to get the most from your *Link 1000* and *Freedom*.

### BEFORE USING YOUR LINK 1000:

#### 1. SET BATTERY CAPACITY

(See P 17 of your manual)  
 Press **SET** 5 sec. (**SEL** in display)  
 Press **SEL** 3 times. (**Ah** light on)  
 Present Ah setting is displayed.  
 200 Amp-hours is default.  
 Hold **SET**. Display scrolls up. When the value you want appears, release the **SET** button.  
 If no keys are pressed for 10 seconds the new Ah number is stored!

#### 2. SET BATTERY TYPE

(See P 22 of your manual)  
 Press **SET** 5 sec. (**SEL** in display)  
 Press **SEL** until **FUNC F10** is displayed  
 Press **SET** to toggle battery Type 1 (liquid cell) or Type 2 (gel cell).

#### 3. VERIFY MEASUREMENTS

With the system wired, and the charger light **OFF**, turn on a load such as a horn light. Press **SEL** once. The **A** (Amps) light will come on. The number of Amps being consumed should be a negative number. If there's no minus sign (-) in front of the number, your shunt leads are reversed.

### UNDERSTANDING STATUS LIGHTS

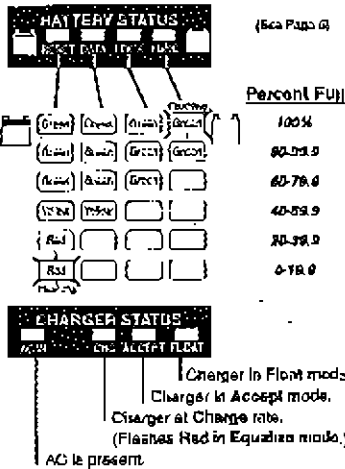

**NOTE:**  
 A 12 Volt battery is dead when V=10.5!

Press **SEL** to show V=Volts, A=Amps, Ah=Amp-hours, T=Time remaining (pages 16-18)

Zero Amp-hours is a full battery. Amp-hours consumed from the battery are displayed as a minus number. Amp-hours count back up toward 2000 when charging.

#### BATTERY DATA

Data order: **CEP** (1995);  
 Cycles (1999);  
 Deepset Discharge (-1999);  
 Average Discharge (1999). (See P. 26)

#### KEY FUNCTIONS

**Pwr Share & Idle Mode** (See P 7)  
**Pwr Share** helps prevent breaker trips!  
**F01** (Scanning) On/Off.  
**F02** (Sleep) On/Off.  
**F03** (Temp) in 10F steps.  
**F08** (Peukert Exponent) (See P 28-32)  
**F10** (Set Battery Type) 1=Liquid, 2=Gel  
**F13** (Display test) (checks lights)

**NOTE:** For detailed information on how to use the *LINK 1000* see the *Owner's Information Package*.

**This page intentionally left blank.**

## **RESPONSIBILITY FOR PROPER LOADING**

As the operator of this motor home, you are responsible for its proper and safe loading. This section is intended to provide you with helpful information concerning the loading of your motor home.

Your motor home chassis is designed to carry a specific maximum weight. This weight includes everything: the weight of the empty motor home itself, all occupants and their belongings, fuel, fresh water, waste water and anything else that may be in or attached to the motor home. *This weight must never be exceeded.* If you do exceed this weight, you will change how your motor home handles and responds, possibly leading to a vehicle crash.

## **SOME DEFINITIONS FIRST**

Before discussing loading and weighing, we need to explain some common weight terms. We will use abbreviations and you should refer back to these terms if you do not understand what the abbreviation means.

### **GVWR (Gross Vehicle Weight Rating)\***

means the maximum permissible weight of this motor home. The GVWR is equal to or greater than the sum of the Unloaded Vehicle Weight plus the Net Carrying Capacity.

### **GCWR (Gross Combined Weight Rating)\***

means the value specified by the motor home manufacturer as the maximum allowable loaded weight of this motor home with its towed trailer or towed vehicle. Towing and braking capacities may be different. Refer to Fleetwood and the chassis manufacturer's manuals for complete information.

### **GTW (Gross Towed Weight)\***

means the maximum permissible loaded weight of a trailer or car that this motor home has been designed to tow. This cannot be increased by changing the trailer hitch.

---

**\*These ratings are shown on the Carrying Capacity label.**

## MOTOR HOME LOADING

---

**GAWR (Gross Axle Weight Rating)\***

means the maximum permissible loaded weight a specific axle is designed to carry.

**TW (Tongue Weight)\***

the maximum permissible downward force exerted on the hitch ball by the towed vehicle coupler.

**UVW (Unloaded Vehicle Weight)\***

means the weight of this motor home as built at the factory with full fuel, engine oil and coolants. The UVW does not include cargo, fresh water, LP gas, occupants, or dealer installed accessories. The UVW is listed on the wardrobe door tag.

**NCC (Net Carrying Capacity)**

means the maximum weight of all occupants including the driver, personal belongings, food, fresh water, LP gas, tools, tongue weight of towed vehicle, dealer installed accessories, etc., that can be carried by this motor home. NCC is equal to or less than GVWR minus UVW.

**Designated Seating Capacity (Canadian units only)**

the number of sleeping positions designated equals the seating capacity.



## CARRYING CAPACITY

PRODUCT	YEAR	MODEL	SERIAL NO	
GVWR				LBS.
GCWR				LBS.
FRONT GAWR				LBS.
REAR GAWR (includes capacity of tag axle if so equipped.)				LBS.
HITCH HAVING _____ LBS.	TONGUE WEIGHT _____	LBS	GTW _____	LBS
UVW (DRY WEIGHT) OF FINISHED VEHICLE				LBS.
NET CARRYING CAPACITY				LBS.

**GVWR (Gross Vehicle Weight Rating):** means the maximum permissible weight of this motor home. The GVWR is equal to or greater than the sum of the Unloaded Vehicle Weight plus the Net Carrying Capacity.

**GCWR (Gross Combination Weight Rating):** means the value specified by the motor home manufacturer as the maximum allowable loaded weight of this motor home with its towed trailer or towed vehicle. Towing and braking capacities may be different. Refer to Fleetwood and the chassis manufacturer's manual for complete information.

**GAWR (Gross Axle Weight Rating):** means the maximum permissible loaded weight a specific axle is designed to carry.

**GTW (Gross Towed Weight):** means the maximum permissible loaded weight of a trailer or car that this motor home has been designed to tow. This cannot be increased by changing the trailer hitch.

**Tongue Weight:** The maximum permissible downward force exerted on the hitch ball by the towed vehicle coupler.

**UVW (Unloaded Vehicle Weight):** means the weight of this motor home as built at the factory with full fuel, engine oil, and coolant. The UVW does not include cargo, fresh water, LP gas, occupants or dealer installed accessories.

**NCC (Net Carrying Capacity):** means the maximum weight of all occupants including the driver, personal belongings, food, fresh water, LP gas, loads, tongue weight of towed vehicle, dealer installed accessories, etc., that can be carried by this motor home. Normal variation of materials may cause the Net Carrying Capacity to be 200 lbs. higher or lower than stated. (NCC is equal to or less than GVWR minus UVW.)

This motor home is capable of carrying up to \_\_\_\_\_ gallons of fresh water (including water heater) for a total of \_\_\_\_\_ pounds.

Reference: Weight of fresh water is 8.33 lbs./gal., Weight of LP gas is 4.5 lbs./gal. (average).

**WARNING: The Heaviest Loaded Motor Home With All Passengers, Goods, Water, Driver And Towed Vehicle Must Not Exceed Any Of The Following:**

1. The gross vehicle weight rating (GVWR).
2. The gross combination weight rating (GCWR).
3. The front/rear gross axle weight ratings (GAWR'S).

**CONSULT OWNER'S MANUAL FOR WEIGHING INSTRUCTIONS AND TOWING GUIDELINES.**

U15263 MHT

Carrying Capacity Label

**TOWING A VEHICLE OR TRAILER****("TOWED LOAD OR TOWED UNIT")**

NOTE: Some states and provinces require brakes and safety chains on towed vehicles. Consult the proper authorities in the states or provinces through which you will be traveling.

When you use your motor home to tow, remember that you must stop the towed load with your motor home's brakes. This is critical on hills and in the mountains where you may encounter sharp curves and possibly irregular road surfaces. Check your motor home **Chassis Operator's/Owner's Guide/Manual** for the maximum weight your motor home can pull and stop on both level and steep roads. If the **Chassis Operator's/Owner's Guide/Manual** does not provide information on towing weight limits, do not tow a load of more than 1000 pounds unless the towed unit has a properly installed and operating supplement brake control system that operates with the brakes on your motor home. The supplemental brakes will NOT allow you to tow more than the listed GCWR for your motor home. *If you cannot stop, you will crash.*

You must not exceed the weight factors listed below if you expect to tow something behind your motor home, either with or without a dolly. The factors are:

- **GCWR - Gross Combined Weight Rating**
- **GTW - Gross Towed Weight**
- **TW - Tongue Weight**
- **GAWR - Gross Axle Weight Rating**

The ratings for these factors are all listed on the carrying capacity label posted inside the motor home.

If you expect to tow with your motor home, there are additional guidelines that you must follow:

## WARNING

**Do not exceed the rated load of the motor home, or the rated load of any axle. Exceeding the GVWR, GAWR, GTW or GCWR of your motor home can cause handling problems, a vehicle crash, damage your motor home and void your warranties.**

- Your motor home is equipped with a 10,000 lb. hitch receiver assembly. Refer to Section 40 "Towing A Vehicle" for information on towing with your motor home.
- Limit the tongue weight to the Towed Weight as listed on the carrying capacity label. Heavier tongue weights can change your vehicle's handling and response, can cause a vehicle to crash, and will restrict your coverage under the Ownerscare Warranty.
- Do not tow anything weighing more than the GTW listed on the carrying capacity label. Heavier towed loads can exceed your chassis' ability to pull and stop the load and cause a vehicle crash, damage the motor home structure or drive train, and restrict your coverage under the Fleetwood or chassis manufacturer's warranty. Changing the trailer hitch will not increase the tow capacity of the motor home.
- Consult the **Chassis Operator's/Owner's Guide/Manual**, and U.S. state and Canadian provincial laws for towing weight limits and for guidelines for installing supplemental braking systems that operate with your motor home's brakes.

## MOTOR HOME LOADING

---

The way your motor home handles and responds will be affected by the way the towed unit is loaded. If the tongue weight is too light in relation to the GTW, handling and response will change and your motor home will operate less safely. Careful load planning and safe experimentation with different loading patterns in what you are towing can avoid this risk and make your driving and towing experience safer and more enjoyable.

### ***Carrying Capacity and Load Distribution***

NOTE: Net Carrying Capacities (NCC) of your motor home are specified on a label affixed to the inside of the motor home. The label includes all factory installed options. If other equipment such as leveling jacks, awnings, roof pods, etc., are installed after the motor home leaves the factory the weight of these items must be subtracted from the total of the passenger and cargo carrying capacities.

The amount of cargo weight you can place in your motor home is the motor home's GVWR minus its UVW, or maximum capacity minus the weight of your motor home as assembled by Fleetwood, i.e., without dealer installed accessories, water, L.P. gas, cargo or occupants. When the motor home is being designed, the number and size of storage compartments, the liquid tank capacities and number of belted seating positions are determined for value and convenience. If you fill all liquid tanks to capacity, fill all storage compartments and cupboards to maximum volume and fill all available seating positions with passengers, the motor home could be overloaded. (See **Loading Tips**). Be aware of the weight of the items you store and where you store the items in your motor home, and weigh your motor home after it is fully loaded.

In addition to knowing the overall weight that can be safely loaded in or attached to the motor home, you must know how to distribute the weight so that correct amounts of weight are distributed between the axles or front-to-rear and also between the wheels or side-to-side. It is also important to place heavier items in under-the-floor storage or low in the motor home. If you make the motor home top heavy or much too heavy on one side, the motor home can be overturned and crash in a curve, turn or in an emergency steering maneuver. When the load is properly distributed, your motor home will handle and respond safely, and you as the driver can be more confident and will be more comfortable.

If your motor home is improperly loaded, it may be unsafe to drive, uncomfortable to drive, or both. Axle load is important and it is recommended that you should load your motor home so that the front axle is loaded to at least 80% of the front GAWR.

## WARNING

Do not exceed the GVWR, GCWR, or any GAWR of your motor home. Exceeding the GVWR, GAWR or GCWR of your motor home will reduce your warranty protection, can cause undesirable handling characteristics and may create a safety hazard.

### ***How To Weigh Your Loaded Motor Home Without A Trailer or Other Towed Load***

Refer to your local telephone directory to find a public weigh station. The following procedures will help you determine whether your loaded motor home (complete with cargo, fluids, passengers, and driver) is within GAWR and GVWR limits. When you arrive at a weigh station, the attendant will guide you through the correct positioning of the motor home on the scales.

1. Center the front wheels on the scale platform and take a reading. This is the front Gross Axle Weight (Reading 1).

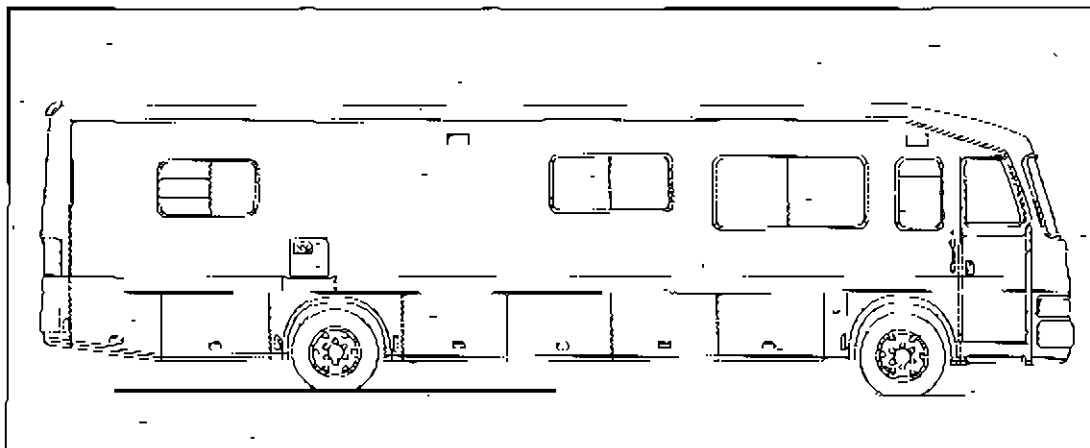

## MOTOR HOME LOADING

---

2. Center the entire motor home (all axles) on the scale and take a reading. This is the Gross Vehicle Weight (Reading 2).

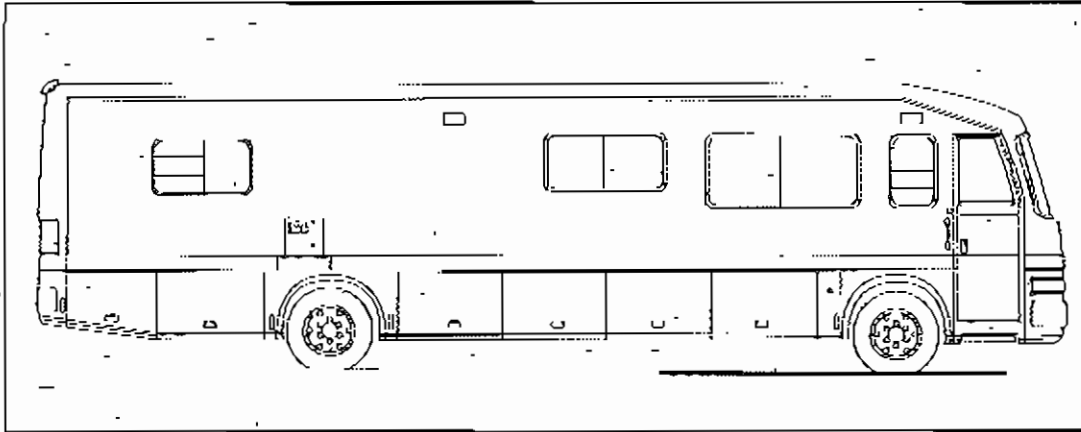

3. Center the rear axle (or both rear axles if your motor home is equipped with tag axles) on the platform and take a reading. This reading is the rear Gross Axle Weight (Reading 3):

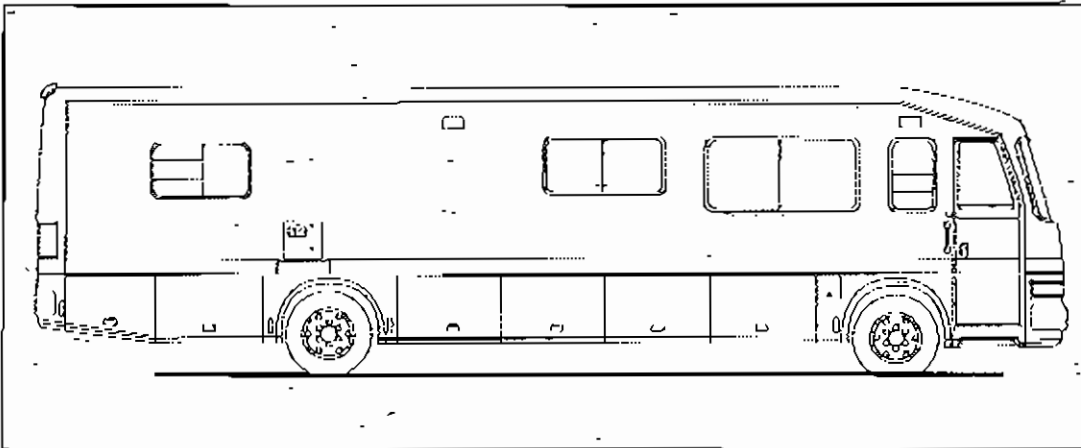

Compare the readings taken on the scales to the appropriate ratings noted on the Federal certification tag and wardrobe door tag. Example: The front Gross Axle Weight should not exceed the front Gross Axle Weight Rating.

If any readings are higher than the rating, you will have to adjust or remove the load.

## ***How To Weigh Your Loaded Motor Home With A Trailer or Other Towed Load***

1. Center the front wheels on the scale platform and take a reading. This is the front Gross Axle Weight (Reading 1).
2. Center the entire motor home so that only the motor home is being weighed. Leave the trailer hitched to the motor home, but resting off of the scale. This is the Gross Vehicle Weight (Reading 2).

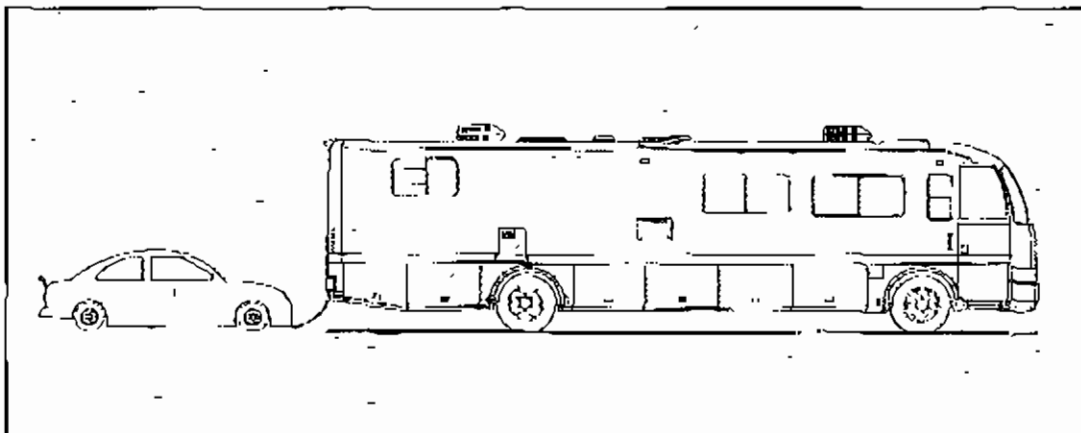

3. Center both the motor home and the trailer combination on the scale and take a reading. This is the Gross Combined Weight (Reading 3).

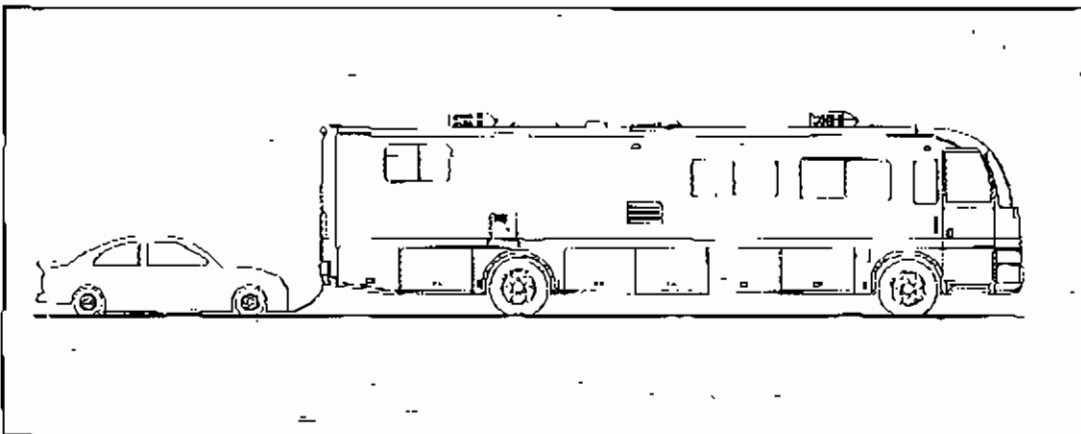

## MOTOR HOME LOADING

---

4. Subtract Reading 1 from Reading 2. This is the rear Gross Axle Weight.

Compare the readings taken on the scales to the appropriate weight ratings on the Federal certification tag and carrying capacity label. Example: The Gross Combined Weight should not exceed the Gross Combined Weight Rating.

If any readings are higher than the rating, you will have to adjust or remove the load.

If you exceed weight ratings, you will:

- *cause unsafe braking*
- *cause unstable driving and handling characteristics*
- *cause damage to the motor home, drive train, or chassis*
- *reduce your warranty protection.*

Since you may load your motor home differently for different trips, loading and weight patterns will change. Periodically reweigh your motor home and log the weights in the back of this manual. Refer to your log as you prepare to load for future trips.

### **Loading Tips**

- *Load heavier items lower.*
- *Do not load heavy items on the bumpers.*
- *Making a loading diagram of your properly loaded motor home, and then weigh the properly loaded motor home. The loading diagram, your loading log and the loaded motor home weight will help you locate where specific items are stored, and will help speed the loading process.*



- *Secure and brace items so they won't move during travel.*
- *Fresh water and waste water weigh over 8 pounds per gallon. Carry only as much water as needed for travel use or to balance the load, and whenever practical, empty the holding tanks before traveling.*
- *Store emergency items in a readily accessible location. As a minimum include a fire extinguisher, tools, first aid kit, rain gear, flashlight, highway warning devices, an electric cord with light, and sturdy gloves.*

## **WARNING**

**Do not store or carry LP gas containers, gasoline, or other flammable liquids inside your motor home.**

## **WARNING**

**Modification of your vehicle by addition of racks or storage pods to carry additional equipment, vehicles or cargo will reduce your warranty coverage and may cause personal injury or property damage.**

This page intentionally left blank.

## **RANGE**

The gas oven and burners are operated with LP gas. The basic operation is the same as the range in your home.

A warning label has been located in the cooking area to remind you to provide an adequate supply of fresh air for combustion. Unlike homes, the amount of oxygen is limited in an RV due to the size and construction of the vehicle. Proper ventilation when using the cooking appliances will prevent the dangers of asphyxiation. Refer to "**Lighting LP Gas Appliances**" section in the "**LP GAS SYSTEM**" chapter of this manual.

## **WARNING**

**Do not use open flames to warm the living area. Gas combustion consumes the oxygen inside the motor home.**

## **RANGE HOOD**

The range hood filters vapors and cooking odors.

The 120-volt range hood is a recirculating type with a charcoal filter canister. This filter requires period maintenance. See the microwave/convection oven operating manual in the **Owner's Information Package** for more information.

As a 120-volt appliance, the range hood will operate only when the motor home has 120-volt service supplied by an external hook-up, the generator, or the inverter operating on 12-volt battery power. The range hood will not operate on battery power except through the inverter.

This page intentionally left blank.

# REAR VIEW AUDIO/VIDEO MONITOR

**33**  
Page 1 of 2

Your motor home is equipped with a rear view video monitor. The camera is located at the top rear of the motor home. The rear view picture is displayed on a screen on the motor home instrument panel. The monitor screen may be overlaid with a distance scale reference which gives approximate distance of objects to the rear of the motor home.

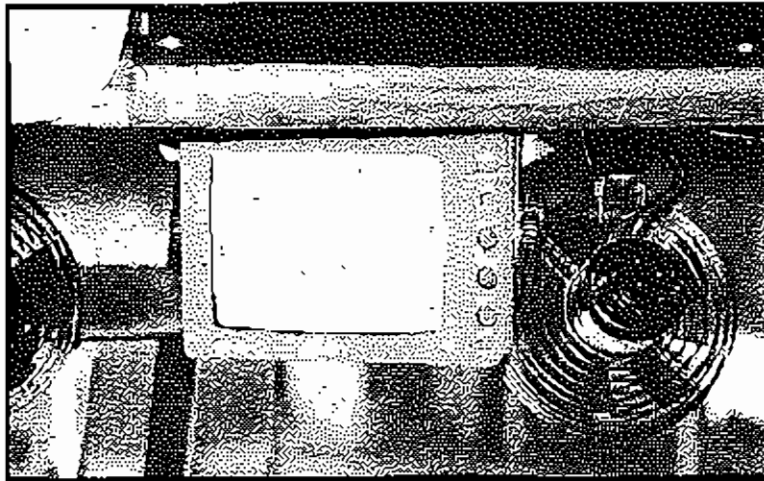

*Rear View Video Monitor*

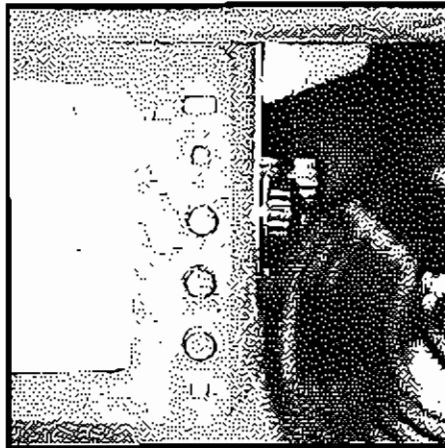

*Audio/Video Controls*

*Note: The back-up monitor has an anti-glare screen. However, if the monitor scale is used, some glare may be noticeable.*

## REAR VIEW AUDIO/VIDEO MONITOR

---

To operate the rear view monitor, the ignition switch must be on and the gear shift in reverse. To override normal operation, the ignition switch must be on and power on at the monitor.

Using the rear view monitor will take practice. Always allow more space for maneuvering until you are comfortable with the system. Check the side-mounted mirrors often while driving and especially during lane changes and when backing up.

### CAUTION

**The rear view video monitor system provides a general view of the road and objects to the rear of the motor home. Your perception of this view and the relationships of objects to the motor home and each other will be different from that seen in a rear view mirror. Light conditions and the adjustment of the screen controls will also affect your perception. Always use the side-mounted rear view mirrors with the video monitor system.**

The camera lens is exposed to road dirt and will get dirty often. Clean the camera lens and monitor screen with a quality glass cleaner and non-abrasive cloth or towel.

The camera can be manually adjusted to change the view seen in the monitor. To adjust the camera, loosen the four angle adjustment screws attaching the camera bracket to the camera. Adjust the camera angle, then tighten the screws. See the camera's Operating Instructions located in the **Owner's Information Package**.

Consult the operating instructions furnished in your **Owner's Information Package**. Before operating the refrigerator when the motor home is parked, make sure it is level. If it is not level, the refrigerant will not circulate, cooling action will stop, and the refrigeration system may be damaged.

The refrigerator uses the absorption principle of operation. If you plan to cool food or drinks in high outside temperatures, pre-cool the food, and park the motor home with the refrigerator vent door in the shade. Once the interior of the refrigerator is cool, the refrigeration system will usually maintain this temperature. If the inside of the refrigerator is hot, the food is not pre-cooled, and the outside temperature is high, be prepared for longer cooling times.

## **TWO-WAY AUTOMATIC REFRIGERATOR**

Your motor home is equipped with a Two-Way Automatic Energy Selector (AES) refrigerator. The refrigerator will automatically select the best available energy source for the conditions, 120-volt, AC power or LP gas. The refrigerator also requires 12-volt DC power to operate the Automatic Energy Selector and the humidity controller.

The refrigerator will only operate on 12-volt DC power when the motor home engine is running.

If battery power is low, a built-in battery protection feature switches refrigerator operation to LP gas. An indicator lamp on the refrigerator will light. When the battery charge level is normal, the refrigerator automatically returns to the 12-volt operating mode.

This page intentionally left blank.



---

---

Seat belts help to restrain you and your passengers in case of a collision. In most states, the law requires their use.

Seat belts provide the best restraint when:

*the seat back is upright*

*the occupant is sitting upright (not slouching)*

*the lap belt is snug and low on the hips*

*the shoulder belt is snug against the chest*

*the knees are straight forward*

For your safety, your vehicle has combination lap and shoulder belts for the driver and front seat passenger and lap belts without retractors in all other designated seating positions.

Always drive and ride with your seatback upright and the lap belt snug and low across the hips to reduce the risk of serious injury to the abdomen or neck that could be caused by sliding under the safety belts in a collision.

Never let a passenger hold a child on his or her lap while the vehicle is moving. The passenger cannot protect the child from injury in a collision.

Children should always ride with the seatback in the fully upright position. When the seatback is not fully upright, there is a greater risk that the child will slide under the safety belt and be seriously injured in a collision.

Never use a single belt for more than one person or across more than one seating position. This greatly increases the risk that one or both of the people will be injured in a collision. Each designated seating position in your vehicle has a specific safety belt assembly which is made up of one buckle and one tongue that are designed to be used as a pair. While your vehicle is in motion, the combination lap and shoulder belt adjusts to your movement. However, if you brake hard, corner hard or if your vehicle receives an impact, the lap and shoulder belt locks and prevents you from moving.

## SEATS AND SEAT BELTS

---

### WARNING

Make sure that you and your passengers, including pregnant women, wear safety belts. Be sure that lap belts fit snugly and as low as possible around the hips. If safety belts are not used properly, the risk of you or your passengers being injured in a collision greatly increases.

### WARNING

Use the shoulder belt on the outside shoulder only. Never wear the shoulder belt under the arm. Never swing it around the neck over the inside shoulder. Failure to follow these precautions could increase the risk and/or severity of injury in an accident.

### **COMBINATION LAP AND SHOULDER BELTS**

While your vehicle is in motion, the combination lap and shoulder belt adjusts to your movement. However, if you brake hard, corner hard or if your vehicle receives an impact, the lap and shoulder belt locks and prevents you from moving.

To fasten the belt, pull the lap/shoulder belt from the extractor so that the shoulder portion of the belt crosses your shoulder and chest. Insert the belt tongue into the proper buckle until you hear a snap and feel it latch.

To tighten the lap portion of the belt, pull up on the shoulder belt until it fits you snugly. The belt should rest as low on your hips as possible.

A longer lap and shoulder belt assembly is available and is a direct replacement for the driver and front passenger positions. The longer lap and shoulder belt is made and tested to the same standards as the original belt. This belt assembly can be purchased and installed at any authorized Fleetwood motor home dealer.

---

## ***SAFETY BELT MAINTENANCE***

Check your safety belt system periodically to make sure that it works properly and isn't damaged. If the webbing shows any wear, nicks or cuts, have it examined by a qualified technician to determine if replacement is necessary. Always have your safety belt system checked after a collision.

## ***SAFETY RESTRAINTS FOR CHILDREN***

In most states, you are required by law to use safety restraints for children. If small children (less than four years old, and under 40 pounds) ride in your vehicle, you must put them in safety seats that are made specially for children. Safety belts alone do not provide maximum protection for these children. Check your local and state laws for specific requirements.

Safety belts and seats can become hot in a vehicle that has been closed up in sunny weather, and could burn a small child. Check seat covers and buckles before you place a child anywhere near them.

### **WARNING**

**Never leave a child unattended in your vehicle.  
Always remove the key from the ignition and take it with you.**

## ***SAFETY BELTS FOR CHILDREN***

Children who are too large for child safety seats should always wear safety belts.

If the shoulder belt cannot be properly positioned so that it does not cross or rest in front of the child's face or neck, move the child to one of the seats with a lap belt only and use the lap belt.

Lap belts and the lap portion of lap and shoulder belts should always be worn snugly and below the hips, touching the child's thighs.

## SEATS AND SEAT BELTS

---

### WARNING

If safety belts are not properly worn and adjusted as described, the risk of serious injury to the child in a collision will be much greater.

Children should always ride with the seatback in the fully upright position. When the seatback is not fully upright, there is a greater risk that the child will slide under the safety belt and be seriously injured in a collision.

### ***SAFETY SEATS FOR CHILDREN***

Use a safety seat that is recommended for the size and weight of the child.

Seat backs should be upright for use with child safety seats.

### WARNING

Carefully follow all of the manufacturer's instructions that come with the safety seat that you put in your vehicle. Make sure that the shoulder belt (if provided at the seating position where the safety seat is being used) does not cross or rest in front of the child's face or neck. If you do not install and use the safety seat properly, the child may be injured in a sudden stop or collision.

### WARNING

When using any infant or child restraint system, it is important that you follow the instructions and warnings provided by the manufacturer concerning its installation and use. Failure to follow each of the restraint manufacturer's instructions could increase the risk or severity of an injury in the event of a collision or sudden stop.

If you need service or warranty information, the following phone numbers may be helpful:

***Fleetwood American Coach Service***

*Warranty or Technical* ..... (800) 435-7345  
*Parts* ..... (800) 344-3245

***Chassis***

*Spartan Motors* ..... (800) 543-4334

***Engine***

*Cummins* ..... (800) 343-7357

***Transmission***

*Allison* ..... (800) 252-5283

**When contacting any of the above, always have model and serial numbers available.**

**Appliance identification numbers will be found on tags or plates attached to the appliance.**

**Chassis component (engine, transmission, axles, etc.) identification numbers will be located in the manuals included with your motor home.**

### ***SUGGESTIONS FOR OBTAINING SERVICE FOR YOUR MOTOR HOME***

If you need service or warranty information, please see the booklets and other documents included in your **Owner's Information Package**. When contacting any of the equipment manufacturers, always have the model and serial numbers available. Appliance identification numbers will be found on tags or plates attached to the appliance.

If you ever need warranty work done, be sure to have the right papers with you. Take your warranty folder. If required work is not covered under the warranty, your dealer's service department can help you with getting the correct service. Always keep a maintenance log of your motor home's service history.

Always make a written list of the motor home's problems or the specific work you want done. If you've had work done that is not on your maintenance log, especially while out of town, let the service advisor know. Don't keep secrets.

And finally, be reasonable with requests. If you have a long list of service items that need attention and you need your motor home very soon, discuss the situation with the service advisor, listing the items in order of priority. This will help the service department manage their time and will help get you going as quickly as possible.

## **EXTERIOR COMPARTMENTS**

Exterior storage compartments maximize available space and should accommodate most of your storage needs. All of the storage compartments except the LP gas and generator compartments can be locked. Fire-prevention regulations require that the LP gas and generator compartments be unlocked at all times.

*NOTE: Lights for the exterior storage compartments are controlled by a single switch on the instrument panel marked LUGGAGE LT.*

Please note: Your motor home could be overloaded or out of balance if not properly loaded. Refer to the "MOTOR HOME LOADING" chapter of this manual, and follow the loading and weighing instructions in that section. When storing equipment and supplies:

Always keep tools and equipment stored in areas where they will not shift while traveling.

Whenever possible, place heavy articles in storage compartments which are low and in the best location for better weight distribution.

Pack articles carefully in the storage compartments to minimize shifting. If necessary, use straps to prevent movement.

Be sure liquid containers are capped and cannot tip or spill. Secure all glass containers and dishes before traveling.

Exterior storage compartments may not be water-tight in all climate conditions. Carry any articles which could be damaged by water inside the motor home.

## STORAGE

---

### WARNING

Do not store flammable, volatile liquids or hazardous chemicals inside the motor home or in outside storage compartments. Toxic fumes from these liquids or chemicals may enter the interior of the motor home.

### *INTERIOR STORAGE*

The closets and cabinets have latches along one edge of the door.

Drawers rest in notches when they are closed. To open drawers, lift up slightly, then pull open.

Closets may be equipped with 12-volt lights that may be switched to turn **ON** when the closet door is opened. Be sure the light goes **OFF** when the closet door is closed — your battery will be discharged if it stays **ON**. If the light stays on when the door is closed, the door switch requires adjustment. The same loading considerations apply to interior storage areas as to exterior. Consult the “**MOTOR HOME LOADING**” section.



## STORAGE CHECKLISTS

The following checklists will help you prepare your motor home for storage. Use the checklist that applies to the storage conditions you anticipate.

These checklists do not include every detail required. You may want to expand them to suit your needs. Contact your dealer for additional suggestions suitable to your climate and storage conditions.

### SHORT-TERM STORAGE (less than 60 days)

Wash the motor home exterior and underside. Hose off accumulations of mud and road salts.

Thoroughly clean the interior of the motor home, including carpets, counter tops, lavy, tub and shower, and galley.

Inflate tires to maximum rated cold pressure.

Park the motor home as level as possible front to rear and side to side. Block wheels front and rear, and leave the parking brake ON.

Check the charge in the battery. Recharge as necessary.

Turn off inverter.

Remove battery cables. Clean terminals, top and sides of batteries and battery boxes. Reinstall cables, dress with a plastic ignition spray. Use battery disconnect switch/es, if equipped.

Drain holding tanks, toilet, and fresh water tank.

Turn off water pump and water heater master switches.

Turn off LP gas at tank valve.

Turn refrigerator and furnace OFF.

Turn off all range-and oven burner valves and pilot valves (if equipped).

Turn off ice maker.

## STORING THE MOTOR HOME

---

- Remove all perishables from refrigerator and galley cabinets. Block refrigerator open to reduce odor buildup. An open box or tray of baking soda in the refrigerator will help absorb odors.
- Open closet doors, drawers, and cabinets to allow air circulation.
- Close and lock all windows.
- Cover exterior appliance vents (water heater, furnace, range hood, refrigerator) to prevent insects from getting in. Be sure to remove all covering material before using appliances or vents.
- Cap or close holding tank drain, city water inlet.
- Turn off all radios, TVs, interior and exterior lights, inverter, battery disconnects, appliances, vent fans and range hood.
- Close curtains and/or blinds, and pull shades.
- Disconnect and store the 120-volt power cord.
- Cover tires with cloth, plywood, or aftermarket tire covers.
- Prepare generator. Refer to generator operating manual included in your **Owner's Information Package**.
- Run the motor home engine for about 15 minutes every 30 days. Turn the vehicle air conditioner ON during this run. Check engine oil, transmission fluid and coolant levels.
- Refer to **Chassis Operator's/Owner's Guide/Manual** for further storage procedures and for start-up procedures after storage.

## LONG-TERM STORAGE (OVER 60 DAYS)

Perform all steps listed under short-term storage.

Run engine to normal operating temperature. Operate air conditioner to lubricate compressor seals. Drain engine oil, replace filter, refill engine with fresh oil.

Remove and store windshield wiper blades.

Charge and remove vehicle, auxiliary and generator batteries. Store them in a cool, dry place. Check the charge and water level every 30 days. Check the specific gravity of the electrolyte periodically with a hydrometer or boost charge every three months. Recharge the battery when the specific gravity reaches 1.220. The time it takes the battery to reach 1.220 depends on its condition and the temperature. The colder the storage area, the slower the battery will self-discharge. A normal time between charges is three months.

Remove, clean and replace air conditioner filters. Cover the air conditioner shroud(s).

Cover the windows on the inside with foil, cardboard, paper, etc., to reduce curtain, drape, and carpet fading.

Remove batteries in clocks or other battery-powered devices.

Check tire inflation pressures every 30 days. Maintain maximum rated cold inflation pressure.

Check the sealant around all roof and body seams and windows. Reseal if necessary. See "Sealant Renewal" section of the "EXTERIOR MAINTENANCE" chapter.

Lubricate all locks and hinges as described in the "EXTERIOR MAINTENANCE" chapter.

Remove excessive grass or weed growth.

# STORING THE MOTOR HOME

## REACTIVATING THE MOTOR HOME AFTER STORAGE

If the motor home was properly and carefully prepared for storage, taking it out of storage will not be difficult. The following procedure check list assumes that you stored the motor home with care. If you didn't, and extensive freeze damage or other serious deterioration has occurred, please consult your dealer or an authorized Fleetwood Service Center for advice.

- Thoroughly inspect the outside of the vehicle. Look for animal nests in wheel wells, under the hood, in air cleaner or in other out of the way places.
- Check tire pressures. Reinflate to specified cold pressure.
- Remove all appliance vents, ceiling vent and air conditioner coverings. Be sure all furnace, water heater, and refrigerator openings are clear and free of debris or insect nests, webs, etc.
- Remove covering from inside windows.
- Open all doors and compartments. Check for animal or insect intrusion, water damage, or other deterioration.
- Open vents and windows for ventilation.
- Check all chassis fluid levels — engine oil, engine coolant, power steering fluid, transmission fluid, rear axle oil.
- Be sure engine instruments indicate proper readings. Run engine up to operating temperature. Shut engine down. Check all fluids. Top up if necessary. Refer to **Chassis Operator's/Owner's Guide/Manual** for after storage start-up procedures.
- Check charge level in batteries. Refill and recharge as necessary. Reinstall batteries if necessary. Be sure cable ends and terminals are clean and free of corrosion.
- During engine run, check the operation of headlights, tail-lights, turn signals, backup lights, clearance lights, license plate light, emergency flashers. Operate the vehicle air conditioner. If air conditioner does not work, or unusual sounds occur, have the system checked by a qualified air conditioner technician.

- Drain, flush, and sanitize the fresh water system as outlined in the **"FRESH WATER SYSTEM"** chapter. Inspect the drain hose for leaks. Replace if necessary — repairs are usually not effective.
- Install a new water filter cartridge (if equipped).
- Operate all faucets and fixtures in the fresh water system. Check for leaks at all joints and fittings. Repair if necessary.
- Check 12-volt circuitbreakers and inspect fuses.
- Operate all 12-volt lights and accessories.
- Install new batteries in battery-operated devices. Check operator's manual for each device for additional requirements.
- Test carbon monoxide, LP gas and smoke detectors.
- Check monitor panel operation.
- Open and operate vents and vent fans, including the range hood fan.
- Inspect the 120-volt electrical system — power cord, converter, inverter, all outlets, and any exposed wiring. If defects are found, refer service to your dealer or an authorized Fleetwood Service Center.
- Prepare the generator for operation following instructions in the generator operating manual in your **Owner's Information Package**.
- Operate 120-volt appliances and air conditioners. Be sure to uncover air conditioner shroud(s).
- Inspect the LP gas system and check for leaks as described in the **"LP GAS SYSTEM"** chapter. If the LP tank shows signs of rust or corrosion, have it inspected by a qualified LP gas technician.
- Operate each LP gas appliance. Observe all burner/pilot flames for proper color and size. In any case, have the LP gas regulator adjusted for proper pressure by a qualified technician.
- Inspect and clean the interior.
- Check the sealant around all roof and body seams and windows. Reseal if necessary. See **"EXTERIOR MAINTENANCE"** chapter.

## STORING THE MOTOR HOME

---

☐ Lubricate all exterior locks, hinges, and latches.

☐ Reinstall windshield wiper blades. Check wiper/washer operation.

☐ Wash and wax the exterior. Inspect the body for scratches or other damage. Touch up or repair as necessary. Flush the underside thoroughly.

☐ Run thorough operational checks of steering, brakes, engine and transmission. Operate vehicle slowly during these checks to allow sufficient circulation of fluids and re-seating of components.

Your motor home should now be ready for a new traveling season. If you choose, your dealer can double check your preparation and correct any defects or make any necessary adjustments.

---

- Your motor home is equipped with wheels and tires selected to match the capacity specifications of the chassis as designed by the chassis manufacturer. Under normal circumstances and with proper tire and chassis maintenance, you should receive many miles of trouble-free service.

## **TIRE INFLATION**

For safety and maximum tire life, vehicle speeds must be proper, proper inflation pressure must be maintained, and tread depth and wear must be monitored. Properly inflated tires also contribute to overall motor home stability and safety. Refer to the tire section in your **Chassis Operator's/Owner's Guide/Manual** or any tire manufacturer's information that may be provided in your **Owner's Information Package** for information on maintenance and tire care.

- The maximum inflation pressures are stated on the Federal Certification Tag located on the sidewall near the driver's seat. To maximize tire performance, consult with the tire manufacturer's guidelines or **Chassis Operator's/Owner's Guide/Manual** for recommended tire inflation pressure. A quality truck tire gauge is supplied with your new coach to emphasize the importance that tire pressure has on your safety, convenience, and tire life.

## **WARNING**

For safety and maximum tire life, check tire pressures often. Pay special attention to inside rear duals. Always check pressure when tires are cold, and do not bleed air out of warm tires. Follow the tire pressure instructions in the **Chassis Operator's Manual**.

## TIRES

---

### WARNING

The tire pressures on your motor home were adjusted to coincide with the weight of the motor home at time of manufacture. These pressures may be lower than the pressures required for the weight of a loaded motor home. Adjust tire pressures on your motor home before your first trip using the information provided in the Chassis Operator's/Owner's Guide/Manual. The tire pressures corresponding to the GAWR's (see Chapter 31) are noted on the Federal certification tag, located next to the driver's seat.

*NOTE: Check the wheel and lug nut tightness periodically. They could work loose during driving. Check the **Chassis Operator's/Owner's Guide/Manual** for correct lug nut torque and torquing procedure.*

### TIRE REPLACEMENT

Replacement tires must be the same size, type and tread depth per axle, and have at least the same weight carrying capacity as the original equipment. All tires of the same size and rating may not have the same weight carrying capacity. Consult your tire dealer. The original equipment tires supplied on your motor home have weight carrying capacities to support Gross Axle Weight Ratings (GAWR) as stated on the Federal Certification Tag located on the sidewall near the driver's seat.

### IF YOU GET A FLAT TIRE

In case of sudden tire failure:

- *Remove your foot from the accelerator.*
- *Use moderately heavy brake pedal pressure. Do not pump the brake. The vehicle is equipped with Anti-lock Brakes (ABS) which will properly control braking.*



- *Firmly hold the steering wheel while avoiding abrupt steering inputs and move slowly to a safe, off-road place.*
- *Park on a firm level surface.*
- *Turn off the ignition.*
- *Set the parking brake.*
- *Turn on the hazard flasher system.*
- *Ensure your passengers are safely located and children monitored.*
- *Get professional help.*

*NOTE: Your motor home is not equipped with a spare tire or a jack.*

## **CHANGING A FLAT TIRE**

Even with good tire maintenance and normal driving, you may experience a flat tire. Summon professional help through your auto club or travel service, or a local truck service facility. Your motor home is not equipped with a jack or other lifting device. Do not attempt to lift the motor home with a jack. Consult the **Chassis Operator's/Owner's Guide/Manual** for additional information on tire inflation and proper torque.

## **WARNING**

**To avoid personal injury and/or property damage if a blowout or other tire damage occurs, obtain expert tire service help. Do not attempt to change the tire yourself.**

## TIRES

---

### WARNING

Truck wheels and tires are extremely heavy and may weigh 100 pounds or more. Do not attempt to remove the spare tire unless you are capable of handling the weight.

*NOTE: If you need on-the-road tire service and call for assistance, be ready to give the tire size information to the service facility. Some service facilities may be able to repair or replace the tire on the spot.*

Your motor home is equipped with one-half of the equipment required to tow a trailer, automobile dolly, or other towed load.

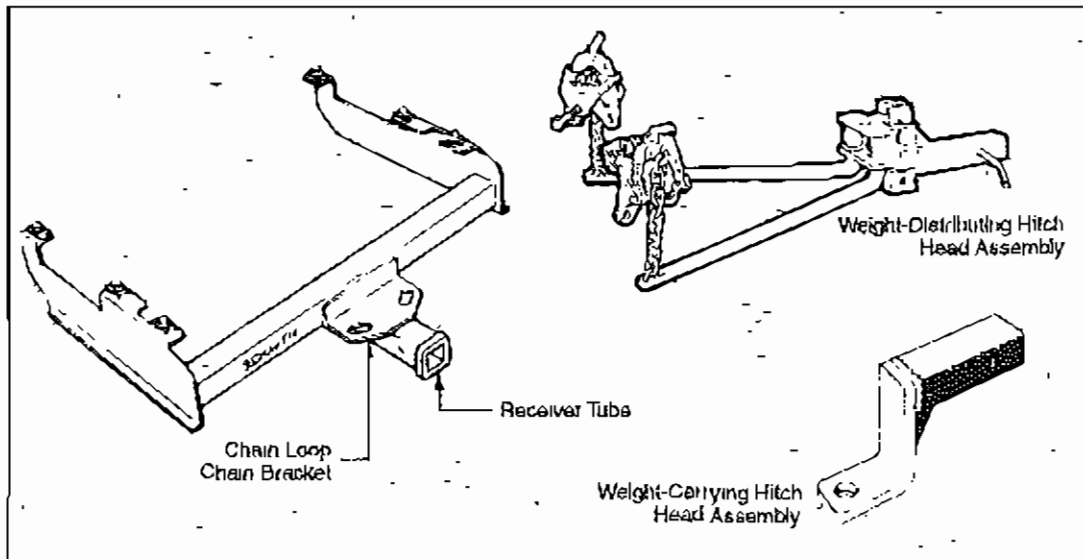

*Typical Hitch System Components*

The equipment supplied with your motor home is called the "hitch receiver." This component is attached to the motor home frame. The square tube opening "receives" any of a wide variety of hitch head assemblies. The "hitch head" is the component that includes the hitch ball.

Hitch head assemblies are available in both "Weight-Distributing" (load-equalizing) and "Weight-Carrying" types. A weight-distributing hitch uses spring bars attached to the trailer tongue A-frame assembly to transfer some of the trailer tongue weight to both motor home axles.

A weight-carrying hitch head assembly does not use spring bars. All of the tongue weight of the trailer bears down on the hitch assembly which loads the motor home rear axle. For this reason, the maximum load you can tow with a weight-carrying hitch head assembly is limited.

## TOWING A VEHICLE

HITCH RECEIVER	HITCH HEAD ASSEMBLY	MAXIMUM TOWED LOAD
10,000 Lbs. (standard)	Weight-Carrying	5,000 Lbs.*
	Weight-Distributing	10,000 Lbs.*

\* To tow the maximum 10,000 lb. load, you **MUST** use a weight distributing hitch head assembly.

\*\* If you use a weight-carrying hitch head assembly, the maximum towed load is limited to 5,000 lbs.

The table above outlines the hitch head assembly combinations and the resulting maximum towed loads that are available to you. The ratings associated with the particular hitch receiver supplied with your motor home are noted on the wardrobe door tag and on a label affixed to the hitch receiver.

Consult with your dealer or towing equipment/trailer supplier to determine the correct type of hitch head assembly you should use for the towed load you intend to pull.

### WARNING

Failure to understand and follow these guidelines as presented in this section could result in damage to the motor home frame or body, could cause unstable driving and handling characteristics, and will restrict your warranty coverage.

## Towed Vehicle Wiring

Your motor home is equipped with an electrical connector, from here on referred to as a hitch plug, which provides an electrical connection for your towed vehicle. The hitch plug is located at the rear of the motor home near the hitch receiver. It is a 7 position connector wired as follows:

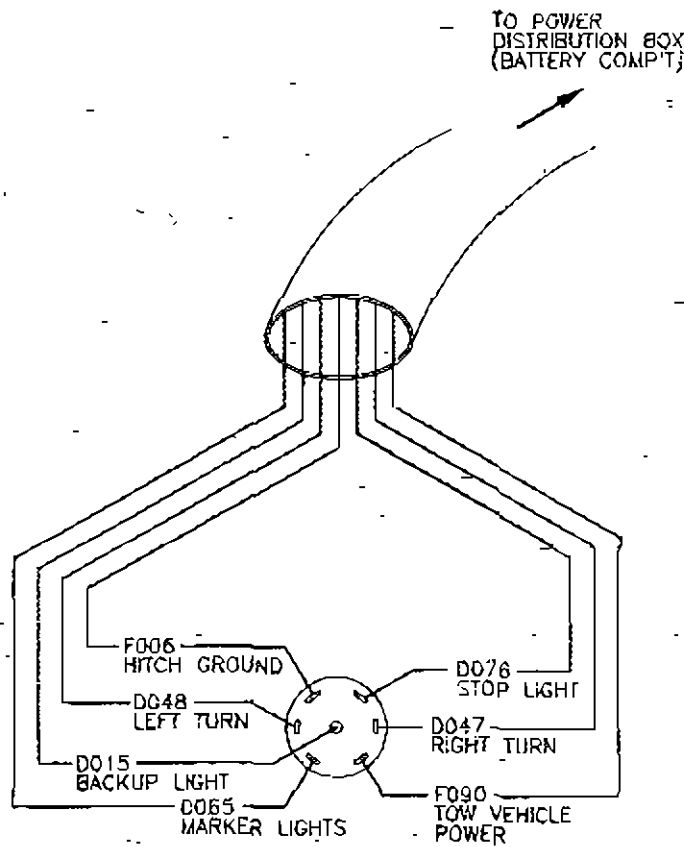

TRAILER HITCH PLUG  
AS SHOWN FROM WIRE SIDE

## TOWING A VEHICLE

Please note this connector provides separate positions for the two turn signals and brake lights. This is necessary for the towed vehicles that have separate amber turn signals in addition to the red brake lights.

Some towed vehicles will not have amber turn signals separate from the brake lights. They will instead use the same lamp to indicate braking as well as turn signal. Towed vehicles with this type of lighting will not be able to utilize the standard hitch plug on your motor home.

For towed vehicles with this type of lighting you will need to replace your hitch plug. A replacement hitch plug wiring harness is available through Fleetwood's American Coach Service. This harness replaces your current hitch plug and is easily installed in minutes. Following is the wiring diagram for this connector:

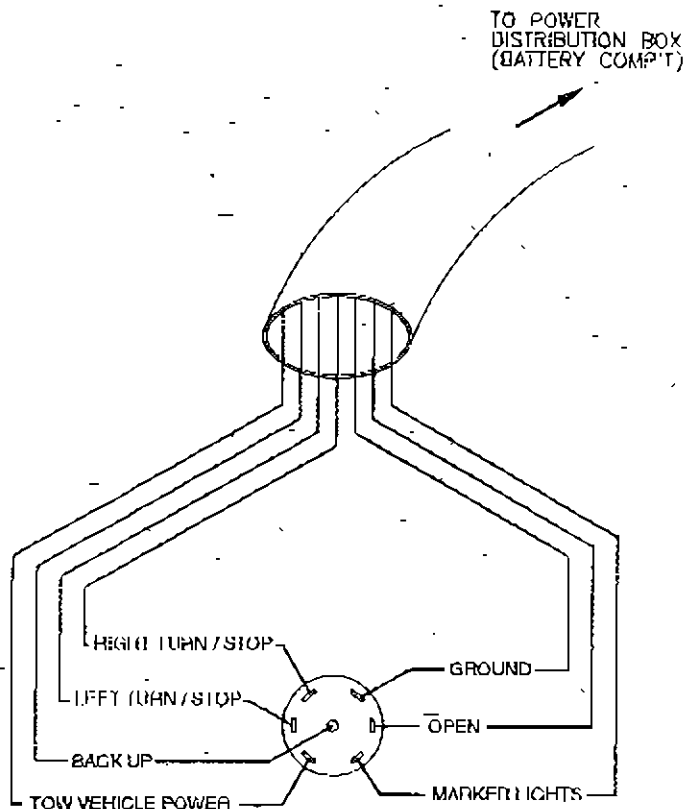

TRAILER HITCH PLUG  
AS SHOWN FROM WIRE SIDE

## **ALLISON TRANSMISSION**

This transmission has an electronic control and monitor system.

### **Starting the Vehicle**

No special procedure is required, although the transmission must be in the NEUTRAL position. The digital display will indicate NEUTRAL.

### **Digital Display**

MONITOR — Displays the range of gears selected by the operator

### **Operation of the Shift Selector**

The push button shift selector has R, N, D,  $\uparrow$ ,  $\downarrow$ , a MODE button, and a digital display. When a range button has been pressed, the monitor displays the chosen operation (if the electronic control unit determines the shift is acceptable), and the transmission will shift into gear. The transmission starts in the lowest gear of the range and as conditions permit automatically upshifts until the highest gear in the selected range is in use.

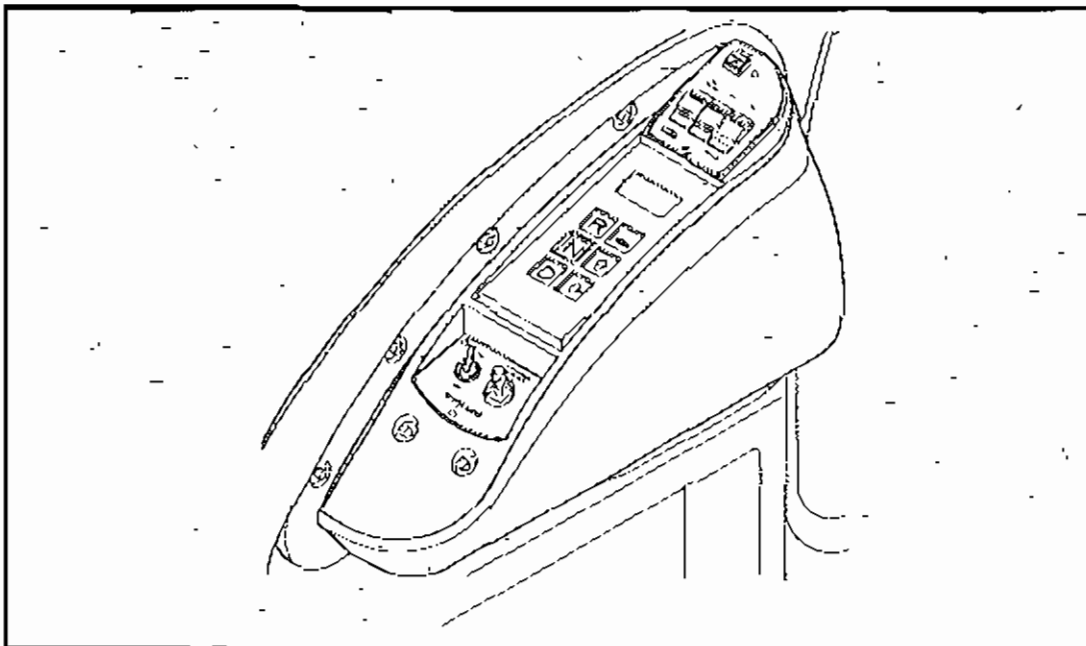

*Shift Selector — Allison Transmission*

# TRANSMISSION OPERATION

---

## **Mode Button**

The MODE button is used to invoke special Electronic Control Unit (ECU) functions. A label adjacent to the MODE button identifies the function associated with a mode change. The mode status will be indicated on the digital display by lighting MODE ON when the function has been selected.

## **Check Transmission Light**

This indicator is located on the instrument panel. Illumination of this light, accompanied by eight seconds of short beeps from the shift selector, indicates that shifts are being restricted.

Operation may continue in order to reach service assistance. On push button shift selectors the ECU will not respond to operator requests since operating limitations are being placed on the transmission; i.e., upshifts and downshifts may be restricted. Direction changes will not occur. The ECU will cause the transmission to shift to a safe gear and Hold-In-Range and disengage the lockup clutch.

Reset procedure to clear CHECK TRANSMISSION light and restore operation.

When the CHECK TRANSMISSION light comes on, a reset procedure can be performed to clear the system. If necessary, continue to operate the vehicle and have the transmission checked at the earliest opportunity.

Bring vehicle to a stop at a safe location and apply parking brakes.

Simultaneously press the UP and DOWN arrow buttons one time.

Press and hold the DISPLAY MODE button until a tone is heard. Then release the button and the transmission will return to the direction attained prior to clearing the active indicator.

*NOTE: If the condition is temporary, the CHECK TRANSMISSION light will not come back on and your vehicle will operate in a normal manner.*



- If the condition is not temporary, the CHECK TRANSMISSION light may come back on and the transmission may remain inhibited or operate in a normal manner until the condition is detected again. The type of operation permitted by the ECU will depend on the type of condition.

## ***Service Indicator***

The SERVICE INDICATOR indicates that the transmission is operating with reduced capabilities. Although the transmission can continue to operate, promptly seek service to minimize the potential for damage. A diagnostic code will be registered in the ECU when SERVICE has been indicated.

If this light illuminates, check for a transmission overheat condition on the instrument panel gauge or overtemp light. If the transmission fluid temperature is outside the normal limits, stop the vehicle at a safe location and summon service. If the temperature is within limits, the vehicle may be carefully driven to a service facility if conditions can be negotiated safely.

## ***Diagnostic Codes***

Illumination of the CHECK TRANSMISSION or SERVICE light during vehicle operation indicates that the ECU has registered a diagnostic code. Diagnostic codes can be displayed on the display portion of the shift selector.

To display the codes:

1. Stop the vehicle, shift into NEUTRAL and set the parking brake.
2. Simultaneously press the UP and DOWN arrow buttons one time. The four digits of the current code and any pertinent parameters are continuously flashed on the display.
3. Press the MODE button to cycle the display to the next code with its pertinent information. Dashes indicate all stored codes have been displayed.

See the **Chassis Operator's/Owner's Guide/Manual** for additional information.

This page intentionally left blank.

The waste water from the sinks and shower drains into the grey water tank; the toilet drains into the black water tank. The holding tanks make the system completely self-contained and allow you to dispose of waste water at your convenience. A flexible sewer hose is required to connect the holding tank outlet to the inlet of an approved waste water dump station or sewer system.

The drain plumbing is similar to that used in your home. The system is trapped and vented to prevent waste gases from backing up into the motor home. The drain plumbing is made of ABS plastic, and is durable and resistant to most chemicals.

## **TOILET**

Your motor home is equipped with a toilet designed for use in marine and RV applications. It may differ in some respects from residential toilets. Please follow the operating instructions found in your **Owner's Information Package**.

## **DRAINING THE HOLDING TANKS**

The holding tanks terminate in a valve arrangement that permits draining each tank separately or together. The valves are called "knife valves". A blade closes the opening in the sewer drain pipes. The blade is connected to a T-handle that is pulled to release the contents of the tank(s). During self-containment use, the sewer line is securely capped to prevent leakage of waste material onto the ground or pavement. **DO NOT PULL THE HOLDING TANK KNIFE VALVE OPEN WHEN THE PROTECTIVE CAP IS INSTALLED ON THE PIPE.** Always drain the tank into an acceptable sewer inlet or dump station.

### **WARNING**

**Holding tanks are enclosed sewer systems and as such must be drained into an approved dump station. Both black and gray water holding tanks must be drained and thoroughly rinsed regularly to prevent accumulation of harmful or toxic materials.**

Whenever possible, drain the holding tanks before traveling. Waste water and sewage in the holding tanks reduce the carrying capacity of the motor home. See "MOTOR HOME LOADING" chapter.

## WASTE WATER SYSTEM

---

Drain the holding tanks only when they are at least  $\frac{3}{4}$  full. If necessary, fill the tanks with water to  $\frac{3}{4}$  full. This provides sufficient water to allow complete flushing of waste material into the sewer line.

During extended or semi-permanent hookups to sewage systems, waste materials will build up in the tank and cause serious plugging if the tank valves are continuously open. In these cases, keep the valves closed until the tanks are  $\frac{3}{4}$  full, and then drain into the sewage system.

The holding tank drain valve outlet is to be used with a removable termination fitting that locks onto the outlet with a clockwise twist. Clamp the sewer drain hose to this fitting. A protective cap should remain in place when you are not draining the tanks.

*NOTE: Local or state regulations may prohibit highway travel unless the holding tank outlet is securely capped.*

To drain the holding tanks:

Attach the sewer hose to the holding tank outlet. Insert the end of the hose into the sewer or dump station inlet, pushing it firmly far enough into the opening to be secure. In some cases, adapters may be necessary between the line and the inlet. Arrange the sewer hose so it slopes evenly.

Drain the black water holding tank first. Grasp the handle of the black water knife valve (the large one) firmly and slide the valve open with a quick, steady pull.

Allow enough time for the tank to drain completely. Rinse and flush the tanks with the San-T-Flush® system located in the exterior plumbing control compartment. When the tank is empty, push the handle in to close the valve. Run enough water into the tank to cover the bottom. This will aid the break up of solid wastes.

To drain the grey water tank, repeat the steps above using the small knife valve. This tank is drained last to aid in flushing the outlets and hose. The grey water knife valve may be left open in a semi-permanent hookup.

## **SAN-T-FLUSH® OPERATION**

*(using sanitizing bottle from kit)*

1. Dump holding tanks in the usual manner at an approved station.
2. Leave dump valves open.
3. Attach garden hose to San-T-Flush® attachment.
4. Remove clear plastic bottle.
5. Place one (1) waste liquefier tablet into screen.
6. Replace the bottle. Hand tighten.
7. Hook water hose to inlet side of the sanitizing bottle cover.
8. Connect the male disconnect to the San-T-Flush® valve (yellow handle).  
Turn the valve to "BLACK TANK."
9. Flush black tank until tablet is  $\frac{2}{3}$  dissolved.
10. While water is running, turn the San-T-Flush® valve to "GREY WATER TANK" and flush until the tablet is dissolved.
11. Turn San-T-Flush® valve to "BLACK TANK."
12. Remove San-T-Flush® attachment and garden hose.
13. Remove the sewer hose and cap the outlet.
14. Rinse out the sewer hose with fresh water and remove the sewer hose from the dump station.

Replace sewer or dump station covers.

## WASTE WATER SYSTEM

---

PLEASE...PRACTICE GOOD HOUSEKEEPING WHEN DRAINING WASTES AT A CAMPSITE OR DISPOSAL STATION. LEAVE THE SITE IN GOOD ORDER. ABOVE ALL, DO NOT POLLUTE.

### **HOLDING TANK CARE**

Since holding tanks don't rely on any sophisticated mechanical devices for their operation, they are virtually trouble free. The most common problem is also an unpleasant one — clogging. You can minimize the chances of clogging by keeping the following considerations in mind:

Keep the black water tank knife valve closed. Fill tank to at least  $\frac{3}{4}$ -full before draining. Be sure to cover the tank bottom with water after draining.

Use only toilet tissue formulated for use in septic tank or RV sanitation systems.

Keep both knife valves closed and locked, and the drain cap tightly in place when using the system on the road.

Use only cleaners that are approved for use in septic tank or RV sanitation systems.

Use a special holding tank deodorant chemical approved for septic tank systems in the black water holding tank. These chemicals aid the breakdown of solid wastes and make the system much more pleasant to use.

Do not put facial tissue, paper, ethylene glycol-based or other automotive antifreeze, sanitary napkins or household toilet cleaners in the holding tanks.

Do not put anything solid in either tank that could scratch or puncture the tank.

If the drain system does get clogged:

- Use a hand-operated probe to loosen stubborn accumulations. Seriously clogged P-traps may require disassembly. Be careful not to overtighten when reassembling.

- Do not use harsh household drain cleaners.

- Do not use motorized drain augers.

Sometimes the holding tank valve will get clogged. In this case, a hand-operated auger may be necessary. Be ready to close the valve *quickly* once the clog is cleared. If the seal gets damaged, it is easily replaced.

This page intentionally left blank.



## **LP/120-VOLT WATER HEATER**

This water heater operates on LP gas, 12-volt DC power and 120-volt AC power. It contains an automatic shut-off valve which stops the gas supply if the water temperature rises too high. This water heater is also equipped with a manual reset high temperature limit switch. The water heater is reached through an access panel on the outside of the motor home.

To operate on:

### **LP GAS**

1. Read Section 28 on **"LIGHTING LP GAS APPLIANCES"** and refer to the water heater's **Operation Guide** located in the **Owner's Information Package**.
2. Fill the water heater with water.
3. Turn the AUX battery disconnect ON.
4. OPEN the LP gas tank valve, turn on the LP leak detector.
5. Place the WATER HEATER switch, located at the galley water pump/water heater panel to the ON position.
6. If the switch light stays on longer than 15 seconds place switch in OFF position and wait 5 minutes.
7. Repeat step 5.

### **120-VOLT AC**

1. Read the water heater's **Operation Guide** located in the **Owner's Information Package**.
2. Fill the water heater with water.
3. One of the 120-volt AC power sources must be supplying power, generator, power cord, inverter.
4. The water heater 120-volt AC breaker must be ON in the breaker box located at the foot of the bed.

## WATER HEATER

---

5. The ON/OFF switch on the back of the water heater must be ON. To access the switch remove the water heater access panel located next to the water heater.
6. The water heater can now be controlled by an ON/OFF 120-volt switch located in the bathroom. Turn the switch ON.

### CAUTION

**Do not turn on 120-volt electricity to water heater unless water covers the heating element. Doing so may burn out the element and void the warranty.**

### CAUTION

**Do not light water heater until it is filled with water.**

Turn on the hot water faucet at the galley sink. If water flows continuously the heater is full.

### **WATER HEATER BYPASS VALVE**

This valve is provided to cut off the flow of water to the water heater. The bypass valve greatly reduces the quantity of antifreeze required to winterize the water system. The valve is located next to the water heater and can be accessed by removing a panel.

To bypass the water heater, turn the lever valve horizontal.

To supply the water heater with water, turn the lever vertical.

## **DUAL PANE WINDOWS**

Your motor home is equipped with dual pane windows which reduce heat or cooling loss. They operate by turning the lock, and sliding window and/or screen open.

*NOTE: Screens on slider windows are not removable for cleaning. They may be pushed out of their frames if the window must be used for emergency exit. In this case, the screens will be destroyed and will probably have to be replaced.*

## **EMERGENCY EXIT WINDOW**

READ AND UNDERSTAND THESE INSTRUCTIONS BEFORE YOU NEED TO USE THEM. The emergency exit window provides an emergency means of escape if the motor home doors are blocked or disabled for any reason or in case the motor home must be evacuated under emergency conditions. To release the window, follow the instructions attached to the window frame.

## **POWER DRIVER'S WINDOW**

The driver's side pod contains controls for the driver window.

This page intentionally left blank.

Thoughtful planning and preparation for the winter season can help eliminate equipment failures and breakdowns, and can extend the life of your motor home and its systems. Your dealer can advise you concerning specific winterization procedures and products for your climate area or the areas through which you will be traveling. Your dealer may also provide winterization service for all appliances and systems in the motor home. The following is a check list if you prefer to perform these procedures yourself:

- Check engine coolant level and antifreeze protection. Drain and flush engine cooling system and add antifreeze to protect the system to the lowest expected storage temperature or at least  $-20^{\circ}$  F.
- Service and winterize the generator as outlined in the generator operating manual included in your **Owner's Information Package**.
- Winterize the LP gas system. Your LP dealer or service station will perform this for you.
- Winterize all appliances as outlined in the individual operator's manuals.
- Remove snow accumulations as often as possible.

## **WATER SYSTEM WINTERIZING**

- Read this section completely before performing winterization.
- Remove water filter cartridge and install the winterizing plug.
- Drain the fresh water tank. Leave valve open.
- Turn water pump on (12-volt power must be on). Open a cold water faucet. When the flow of water stops, turn the pump off.
- Open water faucets, then open the drain valves on HOT and COLD water pipes. Leave these valves open.
- Drain the water heater by opening the drain plug at the bottom of the heater and the safety valve at the top.
- Flush the toilet. Operate toilet sprayer.

## WINTERIZATION

---

- Disconnect washer hot and cold lines and drain (washer/dryer option).
- Run washer through the spin cycle with lines disconnected to remove water from the washer (washer/dryer option).
- Remove washer water filter (located front, bottom, right) and drain (washer/dryer option).
- Drain the shower head by opening the valve. Let all water drain out the tub spout. Leave the valve open.
- When each faucet has been drained, close all faucets, water line drain valves and the fresh water tank drain valve, install the water heater plug and close the safety valve.
- Drain the ice maker by disconnecting the water supply line and operating the appliance for 1/2 hour to cycle out the remaining water.
- Drain the waste water system by following the normal procedure for draining the holding tanks. (See "WASTE WATER SYSTEM" chapter).
- Apply silicone lubrication to the knife valve actuator rod(s).
- Be sure ALL water from ALL plumbing fixtures has been drained.

### CAUTION

Draining the water system alone will not provide adequate cold weather protection. If the motor home is to be unheated during freezing temperatures, consult your dealer for the best winterizing procedure for your climate. Your dealer can winterize your motor home for you or can supply you with one of the special antifreezes which are safe and approved for use in RV water systems. Follow the instructions furnished with the antifreeze.

### WARNING

Do not use automotive or windshield washer antifreeze in the motor home water system. These solutions may be harmful if swallowed.

- Close holding tank drain valves.
- Add approximately five gallons of approved non-toxic antifreeze into the fresh water tank.
- Turn the water pump master switch ON.
- Open each cold water faucet, run the water pump and let about a cup of antifreeze solution flow continuously through each faucet. Close each cold water faucet.
- Flush the toilet until the antifreeze solution flows continuously. Release flush mechanism.
- Winterize the water heater according to the instructions provided with the water heater operating manual.
- When filling the plumbing systems with antifreeze, be sure to open and operate all fixtures and valves allowing the antifreeze solution to flow freely.
- Pour one cup of antifreeze solution down each drain (tub/shower, galley sink, lavvy sink, and washer/dryer trap).
- Install all protective caps:
  - City water inlet cap
  - Waste tank drain outlet cap

This page intentionally left blank.



## LAMPS AND BULBS

### *Interior*

Ceiling 48" fluorescent.....	GE F30T8CW
Halogen 10-watt lights.....	Hella 78241
Halogen 20-watt lights.....	Hella 78240
Ceiling 12" fluorescent.....	GE F8T5CW
Driver/Passenger dome light.....	Jensen 1003 12v
Bath vanity light.....	PD 107006 12v
Bedroom reading lamps.....	Jensen 1003 12v
Range hood.....	GE 912 120v
Dinette decor light.....	GE 1141 12v
Bedroom sconce.....	PD 107006 12v

### *Exterior*

Headlight, halogen high beam.....	Sylvania 90051IB3E132B5 12v
Headlight, halogen high-low beam.....	Sylvania 9006HB4EB32B4 12v
Turn signal lights, amber.....	GE 2057 12v
Front clearance lights.....	GE 67DP 12v
Side marker lights.....	GE 194 12v
Mirror turn signal lights.....	GE 1895 12v
Porch lights.....	Jensen 1003 12v
Entry step light.....	GE 193 12v
Rear clearance lights.....	GE 67DP 12v
Back-up lights.....	GE 1156 12v
Stop/turn/tail lights.....	GE 1157 12v
License plate light.....	GE 168 12v
Entry assist handle.....	GE 57 12v
Driving lights, halogen.....	GE 893 12v
Docking lights.....	Trucklite 60 12v

# SPECIFICATIONS

## FUSES AND CIRCUIT BREAKERS

### 120-Volt Circuits

Circuit Description	Rating	Location
Main - 1	50A	Bedroom
Air Conditioner # 1	20A	Bedroom
Portable Appliances	20A	Bedroom
General Purpose	20A	Bedroom
Microwave	20A	Bedroom
Main - 2	50A	Bedroom
Air Conditioner #2	20A	Bedroom
Washer/Dryer	20A	Bedroom
Roadside Patio Receptacle	20A	Bedroom
Refrigerator	15A	Bedroom
Water Heater	15A	Bedroom

### 12-Volt Circuits

Circuit Description	Rating	Location
Bedroom Area	20A	Bedroom
Water Pump/Water Heater	15A	Bedroom
Galley Area	20A	Bedroom
Galley Ceiling Lights	20A	Bedroom
Slide-out Room	30A	Batt Comp
Bath Area	20A	Bedroom
Living Area	20A	Bedroom
Living Area Ceiling Light Switch	20A	Bedroom
Living Area # 1 (Dinette Lights)	20A	Bedroom
Rear Furnace	15A	Bedroom
Front Furnace	15A	Bedroom
Freezer	10A	Bedroom
Antenna Booster	20A	Bedroom
Luggage Compartment Lights	20A	Batt Comp
Water Pump Switch	15A	Bedroom
Water Heater Switch	15A	Bedroom
Water Heater Lights	15A	Bedroom
Main Power	150A	Batt Comp
Inverter	300A	Batt Comp
Transmission Power	10A	Batt Comp
Brake Lights	5A	Dash
Ignition Power	10A	Dash
Horn Power	10A	Dash
Hazard Power	10A	Dash
ABS Power	20A	Dash

## 12-Volt Circuits (Continued)

Circuit Description	Rating	Location
Marker/CC Lights	20A	Dash
Headlights	15A	Dash
Cigar Lighter	15A	Dash
Driver's Seat Power	30A	Dash
Passenger Seat Power	30A	Dash
Dome Light Power	15A	Dash
Radio Memory Power	5A	Dash
Turn Signal Power	10A	Dash
Instrument Power	5A	Dash
Cruise Power	10A	Dash
ABS Ignition Power	5A	Dash
Wiper Power	20A	Dash
Power Windows	20A	Dash
Leveling Jacks	15A	Dash
Dock Light Power	15A	Dash
Fog Lights	15A	Dash
Exhaust Brake Power	10A	Dash
Heater/Defrost Power	30A	Dash
Radio Power	10A	Dash
CB Radio Power	15A	Dash
Overhead Fan Power	15A	Dash
Spot Light Power	15A	Dash
Wt Ignition power	10A	Batt Comp
Stop Light Power	15A	Batt Comp
Right Turn Relay Power	5A	Batt Comp
Left Turn Relay Power	5A	Batt Comp
Back-up Light Power	7.5A	Batt Comp
Air Dryer	10A	Batt Comp
Moisture Ejector	20A	Dash
Tow Vehicle	30A	Batt Comp
Tail/Marker Power	20A	Batt Comp
Alternator Ignition	10A	Batt Comp
Engine Preheat	15A	Batt Comp
Hood Lamps	5A	Dash
Heater A/C	30A	Dash
Auto Heater	15A	Batt Comp
Condenser Fan	20A	Batt Comp
Heated Mirror	10A	Dash
Remote Mirror	5A	Dash
Camera Power	5A	Batt Comp

# SPECIFICATIONS

## TANK CAPACITIES

### *Fresh Water*

Model 40DS .....	100 gal.
Model 37RS .....	85 gal.
Model 40VS .....	100 gal.

### *Gray Water*

Model 40DS .....	60 gal.
Model 37RS .....	48 gal.
Model 40VS .....	60 gal.

### *Black Water*

Model 40DS .....	40 gal.
Model 37RS .....	48 gal.
Model 40VS .....	40 gal.

### *LP Gas tank*

Model 40DS .....	42 gal.
Model 37RS .....	38.5 gal.
Model 40VS .....	42 gal.

*Water Heater tank (all models) .....* 10 gal.

## EXTERIOR SEALANT RECOMMENDATIONS

Windshield .....	<i>Silka Flex #255-black</i>
All roof except skylight and clearance lights .....	<i>Univoyal Silaprene M5260</i>
Exterior (except roof) .....	<i>Geocel 2300 Tripolymer Clear</i>
Skylight Sealant .....	<i>Surebond SB140</i>
Threaded black pipe at black and gray water holding tanks .....	<i>Permutex 80726</i>
All fresh water threaded fittings .....	<i>Rectorseal 100 virgin Teflon</i>
All threaded LPG black pipe .....	<i>Rectorseal Slow Dry 5 Soft Set Pipe thread comp.</i>

## ENGINE/TRANSMISSION REPLACEMENT FILTERS

See the Engine and Chassis Operator's/Owner's Guide/Manuals.

## GENERATOR FILTERS

See the Generator Owner's Manual.

Your motor home may be equipped with a slide-out room. The slide-out room is designed to provide additional living space for site set-up.

A detailed operating and maintenance guide is included in your **Owner's Information Package**. Read all instructions for this system carefully before operating the slide-out.

## **CAUTION**

**Never attempt to move your motor home with the slide-out room extended. Damage can occur to the slide-out or motor home.**

This page intentionally left blank.