

DRIVERS MANUAL

Futura FHD2

RHD

Euro 5/EEV/OBD2

1113

DD068602



Foreword

These driver instructions contain information regarding the use of the vehicle. Pay particular attention to the safety regulations and the text concerning operation and maintenance before driving the vehicle for the first time. Make sure this instruction manual is always kept in the vehicle.

This instruction manual contains a number of groups. Each group is marked by a number in the margin (for example, 0) and starts with a table of contents.

The text may contain references to other pages, such as [Instrument panel](#) (📖 37). The number after the book icon indicates the page which contains the information.

There is an index at the end of the book for quick reference.

Please ensure that you are fully familiar with the instructions provided in this documentation, as correct operation of the vehicle, together with regular preventative and scheduled maintenance, is decisive for the vehicle's resale value.

Furthermore, in many cases, this is a condition for a warranty claim.

Vehicle type:

Type ^a

Date of first use

VIN code ^b

Other information

Registration

- a. On the identification plate fitted at the front entrance bay.
- b. On the identification plate. The last eight digits form the chassis number (e.g. XMGDE02CS0H123456).

CONTENT

1	INTRODUCTION.....	1	1
2	OPERATION AND USE.....	17	2
3	SAFETY PRECAUTIONS AND EMERGENCY PROCEDURES	71	3
4	MAINTENANCE.....	81	4
5	REPAIRS WHILST ON THE ROAD	103	5
6	IDENTIFICATION	127	6
7	TECHNICAL INFORMATION	137	7

Disclaimer

© 1113 VDL Bus & Coach bv, Valkenswaard, The Netherlands.

In the interest of continuous product development, VDL Bus & Coach maintains the right to make changes to specifications or products at all times without prior notification.

No part of this publication may be copied and/or published by means of printing, photocopying, digitization or any other means whatsoever without prior written permission from VDL Bus & Coach.

This handbook must be interpreted and used in accordance with Dutch law. Any dispute will be placed before the court in 's-Hertogenbosch, the Netherlands.

1 INTRODUCTION

INTRODUCTION.....	3
WARNING SYMBOLS	4
SAFETY INSTRUCTIONS	4
WARRANTY CONDITIONS	8
ENVIRONMENT	9
GENERAL TIPS	9
BATTERIES	14
AIR CONDITIONING SYSTEM.....	16

INTRODUCTION

Congratulations on purchasing your Futura FHD2.

You've made a good choice.

The Futura FHD2 has outstanding driving characteristics, excellent performance and operational reliability, low fuel consumption and an emphasis on safety and comfort.

Reliability, a long lifespan, safety and a comfortable ride are the characteristics of VDL Bus & Coach products.

Read this manual carefully before driving the vehicle for the first time to allow yourself to make the most of these characteristics and to fulfil your expectations.

A thorough knowledge of the maintenance instructions will increase driver satisfaction and will above all have a favourable influence on the durability of the vehicle. The capabilities of the vehicle can be fully exploited

Purpose

The aim of this manual is to familiarise the driver or user with the vehicle. VDL Bus & Coach wishes to pass on as much information as possible about the use, operation, safety and maintenance of the vehicle.

This instruction manual includes information about standard and optional features.

Alternative equipment, for example manual or automatic transmission, is discussed.

This means that you may skip certain sections in the manual which deal with equipment not fitted to your vehicle.

Layout

The layout of the manual is designed to be practical and to provide a clear overview.

There are 7 chapters in the manual. Each chapter is numbered and is easy to locate using the dark markings in the margins.

Each chapter begins with a detailed contents section, which will help you find your way around the relevant chapter.



An index at the end of the manual will allow you to quickly locate topics.



Make sure this manual is always kept in the vehicle and read it carefully before driving the vehicle for the first time.

WARNING SYMBOLS

The instruction manual includes the following symbols.

Take note of the tip or warning accompanying the symbol!



This symbol gives useful tips to simplify the work.



This symbol indicates a situation which requires extra attention.



This symbol indicates a situation which might result in damage to the vehicle.



This symbol indicates a situation which might result in personal injury.



This symbol indicates a situation which might result in damage to the environment.

SAFETY INSTRUCTIONS

The following safety instructions must be strictly observed in order to prevent endangering your own health and safety, as well as that of others.

See also [Safety precautions and emergency procedures](#) (71)

Warnings and safety instructions

Always read the instructions and warnings on labels and stickers.

Do not ignore them. They are there to ensure your health and safety!

ENGINE

Do not allow the engine to run in a confined or unventilated space.

Engine compartment

Keep away from moving parts.

Coolant reservoir filler cap

Do not remove the coolant reservoir's filler cap whilst the engine is at the operating temperature. Release the pressure first by slowly removing the filler cap.

Warning triangle

Always have a warning triangle in the vehicle (it is a legal requirement in some

countries) and possibly some other means of marking.

Safety vest

When carrying out emergency repairs, always wear a safety vest (it is a legal requirement in some countries) and, if necessary, also use other means of marking.

Fire extinguisher

Ensure that you are always in the possession of a fire extinguisher (it is a legal requirement in some countries). Its location is marked by a sticker in the vehicle's interior (see [Fire extinguisher](#) (77)).



In the event of a fire: Certain plastic seals can, in the event of a fire, form gases which together with water form a corrosive acid. Therefore, do not touch any fire extinguisher fluid on the vehicle without wearing protective gloves.

First-aid kit

Ensure that you are always in possession of a first aid kit (it is a legal requirement in some countries), see: [First-aid kit \(📖 78\)](#).

Winter conditions

Whenever severe winter conditions are expected, make sure to fit winter tyres and snow-chains. **See also** [Wheels and tyres \(📖 139\)](#).

Luggage

All luggage must be stowed so that it cannot shift or fly loose, even in an emergency stop. Bear in mind that the driving characteristics of a fully loaded vehicle differ from those of an empty vehicle.

Fluids and greases

Certain fluids and lubricants may be harmful to your health if they come into contact with your skin, are ingested or are inhaled. Therefore, avoid physical contact where possible.

Spilled fluids may react aggressively with other materials, so clear them up as quickly as possible.

To prevent risk of fire the engine and its surroundings must be kept free of (highly) flammable materials.

Welding

Read the workshop instructions before carrying out welding work on the vehicle and/or the bodywork.



Not observing these instructions may result in damage to the vehicle's electronics.

Batteries



Never disconnect the battery terminal clamps whilst the engine is running!

Always disconnect the battery's earth cable when working on the electrical system.

Never place tools on the battery. It may cause a short circuit or even cause the battery to explode.



See [Tachograph \(📖 42\)](#) for instructions on how to disconnect the battery cables.

Charging the batteries

When charging the batteries, make sure there is good ventilation and avoid sparks and a naked flame.



Allow frozen batteries to thaw and remove all the filler caps before charging.

First connect the battery charger's positive clamp (+) to the battery's positive terminal (+) and then the negative clamp (-) to the negative terminal (-).

When the batteries have been charged, turn off the battery charger and then disconnect the negative clamp (-) first followed by the positive (+) clamp.

The battery cables may remain connected for normal charging.

Only use a quick-charger in the event of extreme urgency.



To avoid damage to the vehicle's electronics, both battery cables must be disconnected when quick-charging.



Do not use a speed starter set to start the vehicle as this may damage the vehicle electronics.

Starting the vehicle using an auxiliary starting device

See [Jump starting](#) (📖 122) for instructions on how to start the vehicle using auxiliary starting devices.

System voltage

The vehicle has a 24 V electrical system. When replacing or upgrading electrical or electronic components, ensure that they are suitable for this voltage.

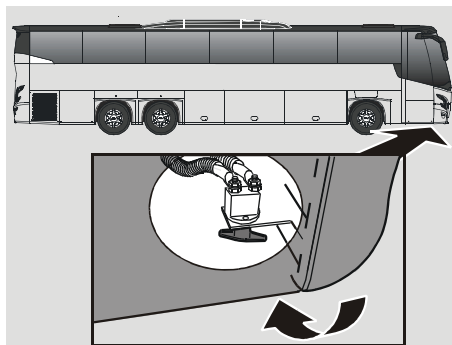

ILHh0041

Earth switch

To prevent the batteries from discharging during long term parking (more than 2 weeks), the vehicle is provided with an earth switch which, when switched off, disconnects the entire coach power supply.

Before switching off, take care that:

 See [Tachograph](#) (📖 42) before switching off the earth switch.

- Stop the engine by first switching off the ignition. Then turn off the main switch.
- Switch off the alarm.

- Disconnect mains voltage connection (24 V connection for charging batteries via mains voltage) if applicable.
- Switch off the earth switch after a delay of at least 90 seconds, to allow for the after-running of various electrical systems on the vehicle.



Failure to meet the switching off conditions may have serious consequences for various electrical systems in the vehicle.

After switching on, adjust:

- The radio (default radio stations).
- Adjust the navigation system.
- The Clock.
- The timer of the control panel of the climate system.
- Tachograph:

If DTCO:

The tachograph keeps its adjustments and needs therefore no further adjustments.

Mobile telephones and transmitters

The following precautions relate to the installation and use of mobile telephones and transmitters.

- It is permitted to install mobile telephones and transmitters in the vehicle if this is done carefully and is approved by VDL Bus & Coach.
- Mobile telephones and transmitters may be used in the vehicle if they have their own exterior, low-reflection aerial. This external aerial must be fitted correctly.



Using mobile telephones or transmitters without a separate external aerial may cause excessive electromagnetic fields (the resonance effect) within the vehicle. This can lead to the vehicle's electronic equipment not working correctly, which will have a negative effect on the safety of the vehicle.



- In addition, the optimum range of this equipment can only be achieved with the use of an external aerial.



Always follow the operating instructions for mobile telephones and transmitters.

- The transmitting power must not exceed the maximum permitted transmitting power. See the table given below:

Frequency range:	Maximum transmitting power:
Shortwave (<50 MHz)	100 W
4 m band	20 W
2 m band	50 W
70 cm band	35 W
25 cm band	10 W

Installation of additional electrical/ electronic equipment

All electric/electronic components retrofitted to VDL Bus & Coach vehicles must have type approval and the "E" marking in accordance with the ECE Guideline R10.



Interfering with the electronic system in any way may create a dangerous situation due to the system malfunctioning and will affect the warranty.



Damage or consequential damage caused as a result of the installation of equipment not approved by VDL Bus & Coach will not be covered by the VDL Bus & Coach warranty.



The vehicle's type approval may no longer be valid (.....) if the electronic or electrical devices used in the vehicle do not satisfy the stated conditions.

Vehicle weights

Take care not to exceed the next weights.

- Maximum weight per axle
- Maximum vehicle weight (GVW)
- Maximum train weight (GCW)
- Maximum trailer weight

See also the vehicle identification plate.

Furthermore, conform to EU Guideline 96/53 EC, it is not permitted to drive a two-axle vehicle with a GVW > 18 tons or to drive a three-axle vehicle with a GVW > 26 tons internationally within the EU.

Retrofitted equipment

All materials retrofit to a VDL Bus & Coach vehicle which belong to the category of materials which should conform to fireproof regulations must meet EU Guideline 95/28 EC.

Original VDL Bus & Coach parts

All parts and components are carefully matched to each other, which among others determines the original VDL Bus & Coach quality.

Do not modify your vehicle with non-original VDL Bus & Coach parts.

Bear in mind that any modification to your VDL Bus & Coach vehicle with non-original parts may adversely affect its performance, safety, durability and the guarantee.

Modifications may also conflict with legal requirements.

WARRANTY CONDITIONS

Please ensure that you are fully familiar with the instructions provided in this documentation, as correct operation of the vehicle, together with regular preventive and scheduled maintenance, is decisive for the vehicle's re-sale value.

Furthermore in many cases this is a condition of the warranty provided.

The warranty conditions are mentioned in the "GENERAL SALES CONDITIONS" and in the "WARRANTY CONDITIONS".

ENVIRONMENT

To prevent unnecessary damage to the environment, you should observe the following guidelines:

- Used liquids should be carefully collected and separated, and should then be handed over to an authorized site for recycling or disposal.
- Improper disposal of liquids is a criminal offence.
- Make sure the vehicle is regularly maintained. A properly maintained vehicle uses fuel more efficiently and emits less harmful exhaust gases.
- Do not allow the engine to idle unnecessarily and always drive using the appropriate engine speed.

GENERAL TIPS

Take note of the following recommendations before using the vehicle:

Pre-heater

- Do not allow the pre-heater to run in a closed or unventilated space.
- Do not operate the pre-heater where flammable or explosive materials, gases or dusts may be present.
- Do not operate the pre-heater over dry grass or other dry ground cover.
- Switch pre-heater off while refuelling vehicle and before entering fuelling stations.
- Never touch hot components of the heating system.

Refuelling



Switch off the engine and switch off the pre-heater before filling fuel tanks.

Use only diesel which is of a suitable quality.

Make sure the filler cap and the area around it are free of dust and avoid mixing water with the fuel when refuelling.



To prevent water condensation, do not allow the level of fuel in the tank to fall unnecessarily low.

AdBlue level

The EAS system consumes AdBlue liquid. The display on the instrument panel shows the tank contents of AdBlue liquid. A yellow warning 'AdBlue level low' is shown if the tank contents have decreased to a specified minimum value. Fill up the AdBlue at the first opportunity. Insert the delivery nozzle fully into the neck of the tank so that the magnet in the neck opens.

Avoid AdBlue liquid coming into contact with painted components. Spilt AdBlue can be easily removed with water.



AdBlue turns white when it dries. This white deposit can also be removed with water.



AdBlue is not poisonous and not harmful to the environment.

AdBlue legal minimum level

The EAS system switches off when the tank contents decrease below the absolute minimum. A yellow warning 'AdBlue tank empty' is shown.



This prevents the EAS unit from sucking in air.

A warning is displayed and the MIL indicator appears.



If this warning is ignored, automatic engine torque reduction may be expected.

The torque limiter is activated once the vehicle has been stationary for two seconds. Once the reason for the torque restriction has been removed, the full engine torque will be available after the

next time the vehicle has remained stationary.



The EAS system is deactivated when the AdBlue temperature falls below -10° C.



It may be considered a criminal offence not to use AdBlue according to the vehicle's specifications in order to reduce harmful emissions. It can invalidate the favourable conditions for purchase or operation of the vehicle obtained in the country of registration or the country in which the vehicle is used.

Running in

It is recommended to avoid placing the vehicle under a too heavy load during the running-in period.

This also applies when a reconditioned engine, gearbox or differential has been fitted.

For the first 1,500 km, you should, therefore:

- Avoid driving with a full load.
- Change down gear in good time: a relatively high engine speed is less harmful than overloading the engine with excessively low engine speeds.
- Do not drive with a trailer attached.



Following a cold start, use a moderate engine speed and avoid heavy acceleration until the engine reaches the operating temperature.

Pay attention to the instrument panel whilst driving and respond alertly when irregularities are observed.

Wheel nuts

The wheel nuts must be retightened using a torque spanner (600 Nm ± 3%) when 100 km have been travelled following delivery of the vehicle.

Fuel economy

Driving economically does not mean driving slowly. It requires the driver to anticipate situations, to have a smooth driving style and to adapt his/her driving style to the conditions.

Keep the following in mind:

- Warm the engine as quickly as possible by driving off as soon as possible under a moderate load.
- Drive smoothly and avoid unnecessary acceleration and harsh braking.
- Change gear in good time and keep the engine speed in the optimal (green) range.

The most significant factor in fuel consumption is the driver himself and how he uses the accelerator pedal, the brake pedal and the gear lever.

Starting procedure



The engine cannot be started with the bonnet open.

Turn on via the main switch.

Depress the clutch pedal (not applicable to vehicles with automatic gearbox) and select neutral gear.



The engine cannot be started when the gearbox is not in neutral.



The following only applies to vehicles with an AS Tronic gearbox.

If the accelerator pedal is depressed when starting the engine, "FP" will be displayed on the dashboard and the vehicle will not select a gear.

Switch on the ignition.



After the engine has started, the engine speed should not be increased until the oil pressure warning light has gone out.

Clutch

Wear on the clutch depends to a great extent on the driver.

To reduce clutch wear to a minimum, follow these guidelines:

- On moving off, always select first gear and where possible a low engine speed.
- On accelerating after a gear change, give gas only after the clutch is fully engaged.
- Avoid riding the clutch.
- Avoid unnecessary acceleration in traffic queues.
- Use the brakes to stop.

Braking

The vehicle is equipped with an EBS (Electronic Braking System) system. Some important control functions within the EBS system are:

- Braking deceleration control
- Wheel slip control between the front and rear axles for the purpose of braking force equalisation
- Braking equalisation control between prime mover and drawn vehicle
- ABS (Anti Block System) control
- ASR (Anti Skid Reduction) control

When the brakes are applied whilst driving, the electronic unit will measure various signals. This results in average readings for: deceleration, brake pressure, wheel slip, etc. These readings will be stored in the electronic unit. The stored readings will be adjusted as necessary. In other words, the electronic unit 'learns' from the inputs. The stored readings serve as a starting point for the deceleration and brake force distribution.

 **This system provides more safety, but it may not be a motive to take unnecessary risks whilst driving.**

 **Do not adapt your driving and braking style to the EBS system.**

In particular, do not brake later or harder. This will cause the tyres to wear more quickly and will put other road users at risk.

 **Braking distances with EBS are sometimes, but not always, shorter.**

Retarder integration

Retarder integration is automatically available in the EBS system. The EBS system can also use braking torque support from the retarder. This has a positive effect on the service life of the brake linings

Retarder integration can be switched off, see: [Vehicle functions](#) (📖 59).



ESC (Electronic Stability Control)

 **A vehicle equipped with ESC may unexpectedly brake hard in certain situations. Therefore, always wear a seat belt.**

The ESC system (Electronic Stability Control) is a system comprising lateral and vertical stability control. If a critical situation arises when taking turns, for example when the vehicle is slipping or threatens to turn over, ESC intervenes by

reducing the engine torque and activating the braking system.

 **ESC is not a guarantee against instability. It helps the driver in unexpected, difficult situations, but there are physical limitations.**

Stopping

Bring the vehicle to a halt.
Select neutral gear.
Allow the clutch pedal to rise (not applicable to vehicles with automatic gearbox).

Parking



Exhaust system

The vehicle is equipped with a catalytic converter. The catalytic converter/exhaust system becomes very hot whilst driving. Do not park the vehicle or idle the engine over an easily inflammable surface, such as dry leaves or dry grass. This is a potential fire hazard.

Stop the vehicle.

Apply the parking brake by means of the brake lever.

When parking on an incline, the following should be considered:

- Place chocks in front of or behind the wheels of the rigid axle.
- Turn the front wheels so that the vehicle will not head out into the road if it should move for some reason.

Switch off the contact switch and the main switch.

Switching off the engine



After a long journey or when it has been put under heavy load, allow the engine to idle while stationary for a while before switching off.

Park the vehicle.

Stop the engine by first switching off the ignition.

Then turn off the main switch.



Turning off the ignition will activate the delay setting of the EAS system (exhaust gas after-treatment system). This may be audible on the outside of the vehicle (a gurgling noise in the region of the AdBlue tank).

Air leak

A rapidly falling air pressure reading whilst the engine is idling indicates an air leak. The leak must be repaired without delay as the safety of the braking system is impaired.

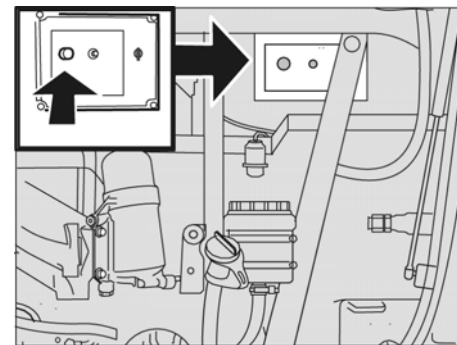

ILHJ0000

Engine stop button in the engine compartment

The engine can if necessary be stopped using the button in the engine compartment.



In the British version, the stop button is accessible via the right-hand rear hatch.



Remember to reset the stop button before closing the engine compartment.

Speed limiter

The speed limiter on your vehicle is set at 100km/h.

BATTERIES

General information

- The more often a battery is discharged, the shorter its lifespan will become.
- The lifespan of the batteries is determined by various factors, including the driving conditions and the climate. Through time, the batteries will lose starting capacity and must, therefore, be recharged if the vehicle is not driven or only driven for short distances for a longer period of time. The starting capacity is also reduced as a result of freezing weather conditions.
- To ensure the maximum lifespan, the batteries must always remain fully charged.
- If the vehicle is mainly used for short journeys or is not used for a longer period of time, then the charging condition of the batteries must be checked regularly or the batteries must be kept constantly charged with a trickle charger.
- Preferably change all the batteries at the same time.

- When changing the batteries, only replace them with batteries recommended by VDL Bus & Coach.

Charging the battery



Explosive oxyhydrogen is produced when recharging the batteries. Therefore, always ensure there is suitable ventilation when charging batteries.

- Avoid sparks and naked flames near batteries.
- Battery acid is an aggressive fluid.
In the event of inhalation: get some fresh air, take a rest and contact a doctor.
In the event of skin contact: neutralize the skin immediately with sodium carbonate or soapsuds and plenty of water. Contact a doctor if the affected area remains red or painful. Remove affected clothing, neutralize with sodium carbonate or soapsuds and rinse with plenty of water.
In the event of contact with the eyes: wash with clean, flowing water for at least 15 minutes and contact a doctor.

If swallowed: DO NOT induce vomiting. Rinse your mouth, drink plenty of water and contact a doctor.

- Always wear protective clothing, in particular, gloves and safety glasses, when working on the batteries.
- Keep children a safe distance from the batteries.
- When charging the batteries, make sure there is good ventilation and avoid sparks and a naked flame.
- Allow frozen batteries to thaw and remove all the filler caps before charging.
- Never disconnect the batteries whilst the engine is running.
- Regularly check whether the battery cables have been connected correctly and whether they are firmly attached to the battery.
- Always disconnect the battery's earth cable when working on the electrical system.

Environment



Batteries contain harmful substances. It is legally prohibited to dispose of batteries with the household waste. Batteries must be collected separately and disposed of in a way which is not harmful to the environment.

- Always transport and store full batteries horizontally. Make sure the batteries cannot tip over during transport. Battery acid may then escape into the environment via the bleed openings or the filler caps.

Personal safety



To avoid injury, the following safety measures must always be observed when working on the batteries.

- Do not bend over the batteries.
- Never place tools on a battery. It may cause a short circuit or may even cause the battery to explode. Only use insulated tools.

- Pay attention to make sure you do not receive an electrostatic charge. Do not wear synthetic (nylon) clothes and do not rub fabric. For the same reason, do not slide or push batteries over a carpet or other synthetic material.
- Do not immediately touch a battery. To reduce the possibility of an electrostatic discharge, first stand outside of the vehicle and touch the bodywork (metal object).
- Do not rub cloths or rags over a battery. The battery may explode as a result of an electrostatic charge or through the creation of a spark.
- Turn off the contact switch and the main switch before disconnecting the battery terminal clamps. If this is not done, electrical components (such as the generator) may be damaged.
- Wait at least 5 minutes after turning off the contact switch and the main switch before disconnecting the connection between the battery terminal clamp and the negative terminal.
- VDL Bus & Coach recommends that you do not carry out work such as charging or removing the batteries yourself. Preferably have this work carried out by a recognized workshop, such as a VDL Bus & Coach Service workshop.

Taking care of the batteries



To avoid freezing when the vehicle is not used for a longer period of time in extremely cold conditions, the batteries must be removed and stored in a location which is frost free.

- To avoid freezing when the vehicle is not used for a longer period of time in extremely cold conditions, the batteries must be removed and stored in a location which is frost free.

AIR CONDITIONING SYSTEM

The Pressure Equipment Directive 97/23 EC came into force on 29th May 2002. Also, European regulation no. 842/2006 regarding certain fluorinated greenhouse gases came into force on 4th July 2006 and many of the requirements came into force on 4th July 2007. The objective of this legislation is, amongst other things, to drastically reduce coolant emissions from cooling installations.

This is achieved by applying the following measures:

- The use of CFCs in new installations is forbidden.
- Technical requirements are placed on cooling installations.
- Work on cooling installations may only be carried out by qualified personnel.

The responsibilities of the owner/operator of the installation are being increased. Implementation is by means of a logbook and maintenance obligation.



Always observe the local legal regulations!



Regularly turn on the air conditioning system (at least once a month), even if no cooling is required, to prevent the compressor from leaking.

2 OPERATION AND USE

DOORS/HATCHES.....	19
CONTROLS AND INSTRUMENTS.....	23
MESSAGES ON THE DISPLAY.....	50
DISPLAY.....	54
PASSENGER COMPARTMENT.....	62
DRIVER'S SLEEPING COMPARTMENT.....	65
TOILET.....	66
KITCHEN.....	67
NAVIGATION SYSTEM.....	67
PNEUMATIC SUSPENSION (ECAS).....	67
STEERING MECHANISM.....	68
MIRRORS.....	69
INSTRUCTIONS FOR DRIVING WITH A TRAILING AXLE.....	70

DOORS/HATCHES

Passenger door/Central door

By turning the key, the handle (1) can be locked/unlocked. By turning the handle, the door is locked/unlocked.

The door is opened/closed with push button (2).

A contact strip on the edge of the door prevents trapping when the door closes.

When the door is closed and the vehicle speed is above 5 km/h, the door can not be opened.

When the door is open and the vehicle speed is above 5 km/h, it will still be possible to close the door (see [Priority 3](#) (📖 53)).

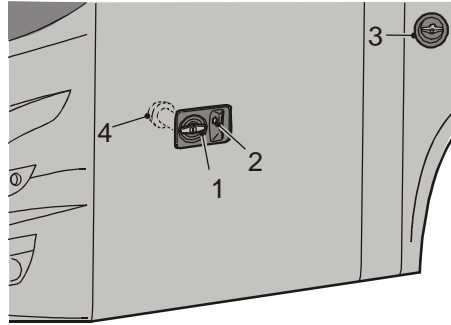

ILHa0000

Connecting the vehicle to an external air supply

If the pneumatic system has been blown off and you wish to connect the vehicle to an external air supply, then the following must be taken into consideration:

- Open both doors.
- Pressurize the pneumatic system.
- Use the control switches to close and open the doors.



To avoid the door system from malfunctioning, it is necessary to follow the described procedure.

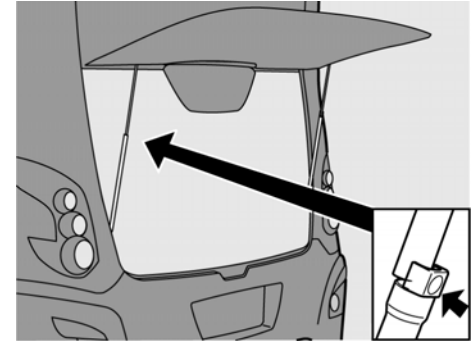

ILHa0001

Engine cover



Avoid contact with hot or moving parts when the bonnet is open.

The bonnet is opened by undoing the lock with the key and pulling at the same time on the bonnet. **The bonnet hinges upwards with the aid of 2 gas springs.** When the bonnet is raised the left-hand gas spring is mechanically locked.



Release the lock before closing the bonnet.

Operation and use

The lock is released by pushing the spacer cover against the spring, allowing the bonnet to be closed.

2

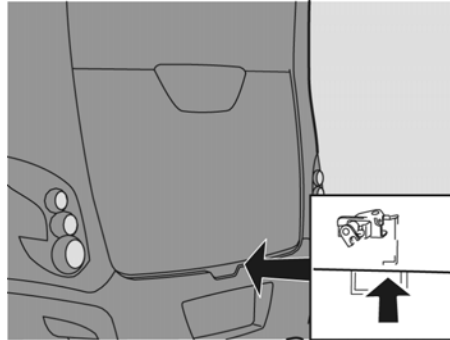

ILHa0003

If the key breaks off in the lock the bonnet can also be opened by pushing up the red lever.



The bonnet can only be opened with this lever when the broken key is still in the lock.

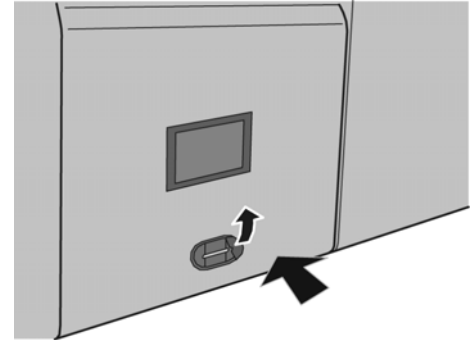

ILHa0004

Luggage hatches / Driver's sleeping compartment hatch

The luggage compartments and the driver's sleeping compartment can be unlocked using the switches on the dashboard. If there is no air pressure available, the compartments can only be opened with a key (see [Luggage hatch emergency operation](#) (📖 76)).



When using a key to open a hatch, the central locking system will no longer function.

To reactivate the central locking system, the hatch must first be locked with the key.

Closing the luggage hatches

Always close flaps by means of the hand grip.

Engine compartment side flap.

The engine compartment side flap may be unlocked with a key and the flap can then be opened.

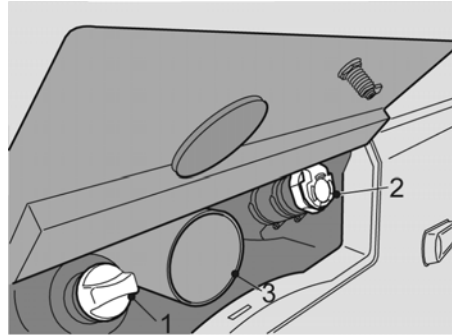

ILHa0002

Fuel lid

The fuel lid can be unlocked with a key. The lid can then be opened to give access to the AdBlue tank (1) and the diesel tank (2).

Glove compartment



Gloves which may be worn when filling fuel tanks can be stored in the glove compartment (3).

Filling

By pressing on the diesel fuel tank cap (2), e.g. with the filling pistol, the fuel tank cap will open.

Having refuelled diesel, also fill up the AdBlue tank with AdBlue liquid.



Switch off the engine and switch off the pre-heater before filling fuel tanks.

2

2

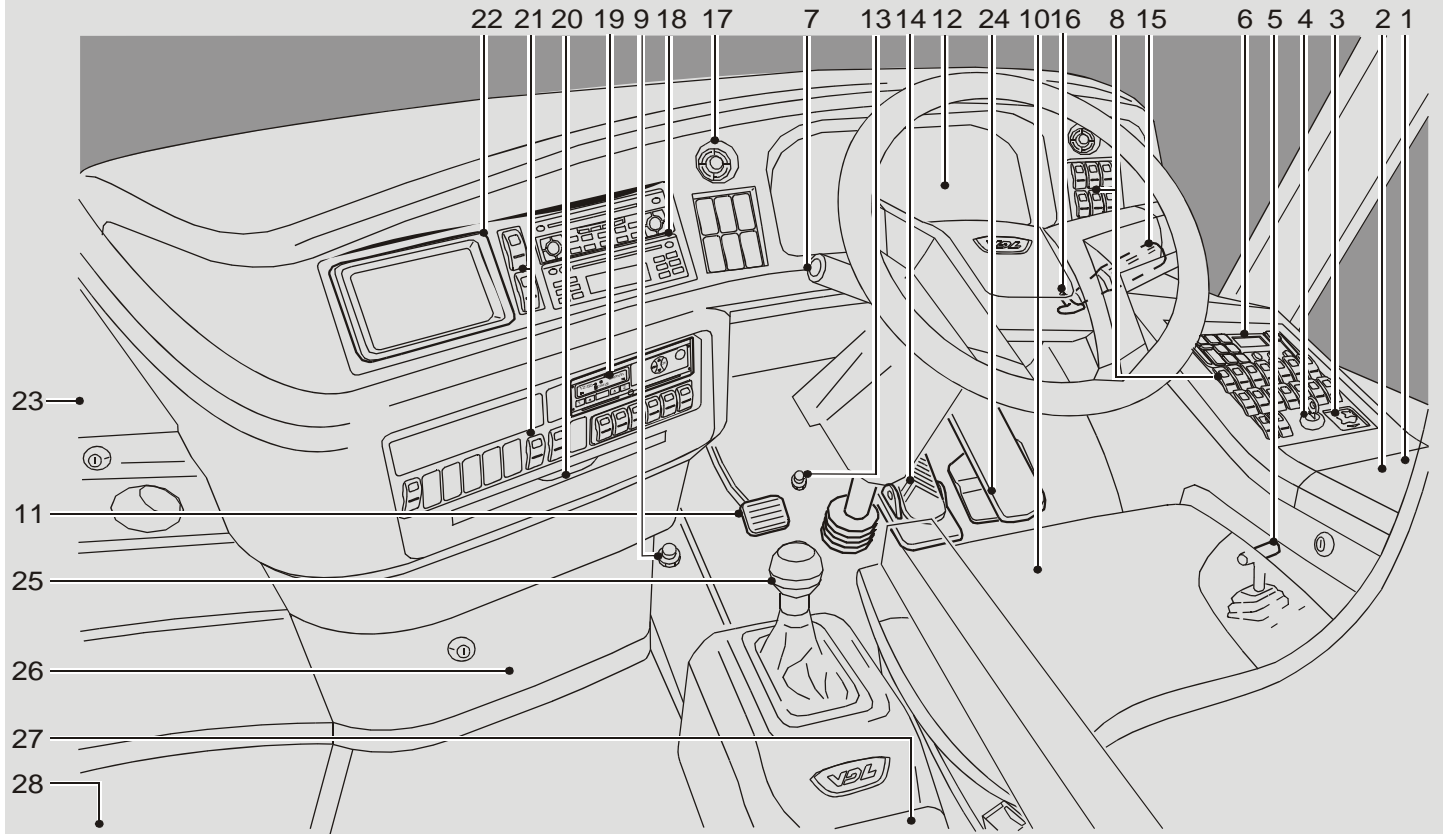

ILHb0005

CONTROLS AND INSTRUMENTS

1. Driver's storage compartment	23
2. 12 Volt and 24 Volt connections	23
3. Mirror adjustment	23
4. Contact switch	24
5. Parking brake	24
6. Climate system controls	27
7. Left-hand combination switch	29
8. Right-hand dashboard switches	30
9. Engine brake	33
10. Driver's seat	34
11. Clutch pedal	34
12. Instrument panel	37
13. Steering wheel adjustments	38
14. Brake pedal	38
15. Right-hand combination switch	39
16. Spare wheel compartment handle	41
17. Ventilation grilles	41
18. Audio	41
19. Tachograph	42
20. Cup holders	42
21. Central dashboard switches	43
22. Navigation system	45
23. Refrigerator	45
24. Accelerator pedal	45
25. Gear shifting	46
26. Central storage compartment	49
27. Storage compartment behind the selector lever	49
28. Hostess seat	50

1. Driver's storage compartment

The upper section is lockable.

The lower section contains the hazard warning triangle, a safety vest and a flash light.

Intercom installation

The microphone for communication with the driver's sleeping compartment is located behind the driver's seat.

For operation of the communication handset see: [Intercom installation \(📖 65\)](#).

2. 12 Volt and 24 Volt connections

There is a 12 Volt connection and a 24 Volt connection under the driver's storage compartment hatch, which are intended for accessories.

The 24 Volt plug also serves as a power supply for the inspection lamp.

The inspection lamp can only be used here if its adaptor plug is fitted, see:

[Plug \(📖 107\)](#)



An electrical consumer of up to 150W may be connected to this holder.



Before connecting an accessory, check which voltage the accessory is suitable for.

3. Mirror adjustment

The mirrors are adjustable electrically, provided the main switch and ignition are switched on, by moving the knob up, down, left or right.



Turning knob to the right operates right mirror.

Turning knob to the left operates left mirror.

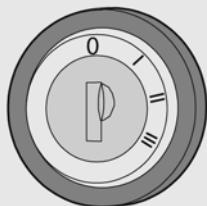

ILHh0025

4. Contact switch

The ignition switch has four positions which, once the main switch is engaged, can be used as follows:

0: Neutral position

The key can be removed.
All electric consumers which may be needed during a journey are now switched off.

I: Position 1

The key cannot be removed. All electric consumers which may be needed during a journey are now switched on.

All instrument indicator lamps are illuminated for 3 seconds for control purposes, and then only those that are active remain illuminated
The fuel gauge and coolant temperature indicators go to maximum and then return to show the current reading.
Switching to position 1 while the main menu is displayed switches to the driving menu.

II: II: Not used.

III: Starting

Operates the starter motor. The key must be turned further to the right against the spring pressure.



The engine cannot be started if the engine compartment door is open.

5. Parking brake

The parking brake operates only on the rear axle and is operated by moving the lever to the rear.

When the parking brake is applied a lamp is illuminated on the instrument panel.



The parking brake is released by moving the lever forwards.

Where air pressure is insufficient the ECAS symbol on the display will be illuminated and the parking brake will not release.

It is necessary to wait for the compressor to charge up the air supply before driving away see: [Information menu \(📖 58\)](#).

If the foot brake is inoperable due to a fault the parking brake may also function as an emergency brake. The vehicle may be brought to a controlled stop by gradually raising the parking brake lever until it reaches its stop.



Using the parking brake as an emergency brake in a vehicle with an AS Tronic gearbox whilst driving on a slippery road may result in the engine stalling. Power assisted steering is then no longer available!

2



ILHg0000

6. Climate system controls

General information

The controls 1 to 4 are the controls for the driver's compartment and the controls 6 to 13 are the controls for the passengers compartment.

1 Recirculated air - driver's compartment

At a push of the button for recirculated-air, the LED in this button and the function „recirculated-air - driver's compartment“ are activated.

2 Frontbox fan

By rotating the switch, the fan speed is adjusted to the required setting. There are five different settings: off, low, medium 1, medium 2 and high.

3 Air supply adjustment for the driver's compartment

By rotating the switch, the direction of the air flow for the driver's compartment is selected. The following settings are possible: foot well fully open, foot well half open / windscreen half open, windscreen fully open, defrost.

4 Temperature adjustment - driver's compartment

By rotating the switch, the temperature is set for the driver's compartment. Rotating fully left max cooling is selected, Rotating fully right max heating is selected. In between the temperature is controlled automatically to the required set temperature.

5 Display

Normally the outside temperature is shown in the display. Depending on which button (1 to 4 for the driver's compartment and 6 to 13 for the passengers compartment) has been operated, corresponding changes will be shown in the display. When for a period of ± 8 seconds no changes have been made, the display switches back to the outside

6 Automatic air conditioning mode

At a push of the air conditioning button, the LED in this button and the function „readiness of air conditioning“ are activated. The air conditioning is switched on when all the conditions (separate functional description) are met.

7 Dehumidify

If the dehumidify button is pressed, the LED in this button is lit and the dehumidify function is activated. The dehumidify function is automatically deactivated 15 minutes after it has been activated.

8 Smog mode for the passenger compartment (and the driver's compartment)

A push of the smog button activates the LED in this button and the „smog“ function.

9 Automatic preheating function

At the push of the button, the LED in this button and the "readiness of pre-heating" function is activated. The pre-heating is switched on after all conditions (separate functional description) are fulfilled.



When only the main switch is turned on, e.g. during cleaning or a service, you can prevent the pre-heater from starting by setting the interior temperature as low as possible using buttons 12 and 13.

10 Fan adjustment in the passenger compartment

If the passenger fan button is pressed, then the fan speed will be activated.

The value can be changed using button 13. When button 13 is pushed for longer than 1 second, the first value changes every second.

11 Setting the clock, switching times and activation periods



The actual time is normally transmitted via the clock in the tachograph/speedometer.

The actual time and the switching time are indicated in hours and minutes in the display.

One can program three weekly programs with one on-duration each which can be activated on as many weekdays as required. Only one on-duration - i.e. the next activated on-duration - may expire, then the activation has to be set anew.

Programming the timer

The timer is activated by a longer push (longer than 2 s) of button 11, the LED in button 13 flashes, and the time, weekday, etc. are adjusted by the right rocker button 13 (+) / (-).

Every chosen program can be opened for adjustment by pushing button 11.

If button 13 (+) / (-) is held during the adjustment, the adjusting speed slowly increases after 2s, in order that the time for example can be set quicker.

For quitting and storing the button 11 has to be actuated again.

The selecting menu is left if another button is pushed during the adjusting process or when no button is pushed for more than 60s.

Activating a program

A short push (less than 2 s) of button 11 opens the indication- and activation mode.

A program time (P1, P2 or P3) can be selected by pressing button 13 (+)/(-) and then activated by pressing button 11.

An activated on-duration is indicated as follows:

When the contact switch is turned on: "LED in button 11" on

When the contact switch is turned off: "LED in button 11" flashes short time in intervals of 3 s

12 Indication of the temperature in the passenger compartment

A push of the button activates the indication of the room temperature. The nominal value can be changed using button 13. When button 13 is pressed for more than 1 second, the value is changed in 1 °C steps every 1 second.

13 Button (+) button (-)

The buttons (+) and (-) form a button for the activation of the fan speed in the passenger compartment (activated by 10), the nominal temperature in the passenger compartment (activated by 12) and the timer (activated by 11).

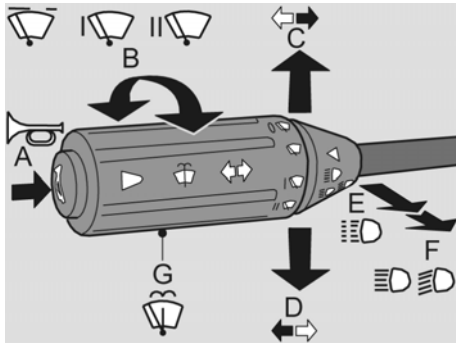

ILHh0010

7. Left-hand combination switch

A. Air horn

The air horn operates when knob A is pressed.

B. Windscreen wipers

The windscreen wipers are operated by turning switch B.

The switch has 4 positions.

Position 0:	Wipers off
Intermittent wipe	In this position the wipers operate every 8 seconds.
Position I:	Wipers on, low speed
Position II:	Wipers on, high speed

C. Indicators, right

Moving the switch upwards operates the right indicator. The green indicator lamp in the instrument also flashes.

D. Indicators, left

Moving the switch downwards operates the left indicator. The green indicator lamp in the instrument also flashes.

For a brief use of the indicators the switch should be pushed slightly against the spring pressure.

E. Main beam flash

To flash the headlights, the switch must be moved upwards until it meets a resistance.

F. Main beam

The main beam works if the switch is moved upwards past the resistance, but only if the contact switch and the dipped beam have been turned on. The blue indicator lamp in the instrument illuminates when main beam is on.

G. Windscreen washers

If part G of the switch is pressed, the windscreen washer installation is activated and the windscreen wipers make two strokes.

Headlight washers

The headlight washers operate at the same time as the windscreen washers, when dipped beam is on.

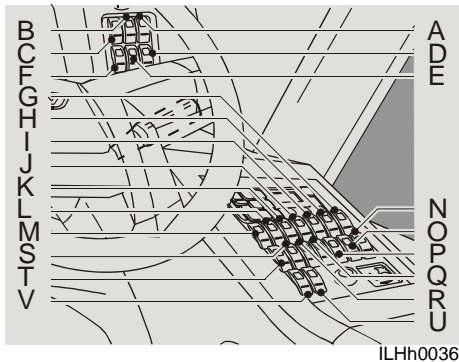

ILHh0036

8. Right-hand dashboard switches

A. Main switch	30
B. Low current protection	30
C. Option	30
D. Front sidelights/dipped beam	30
E. Front and rear fog lights	31
F. Option	31
G. Electrically operated driver's side window	31
H. Electrically heated driver's side window	31
I. Driver's ventilation fan	31
J. Hostess ventilation fan	31
K. Reversing buzzer	31
L. Electrical roller blind	31
M. Electrical roller blind	31

N. Ferry lift/rear kneeling	31
O. Ferry lift/front kneeling	31
P. Switching on and off of the optional wheelchair lift.	32
Q. School bus warning lights	32
R. Right/fixed trailing axle wheels	32
S. Trailing axle relief	32
T. Easy start off	32
U. Select	32
V. Activate	33

A. Main switch

When it is switched on the main switch connects the battery with:



- the switches to operate the doors.
- The ignition.
- audio installation and other accessories, such as video, lighting in the toilet etc.

When the main switch is off the tachograph clock continues to run, the warning system may be used and the pre-heater can be activated if previously set.



The master switch can not be turned off when the engine is running.

B. Low current protection

Switching on overrules low current protection



C. Option

This position is not in use and can, therefore, be used to operate an optional instrument or accessory.

D. Front sidelights/dipped beam

The switch has three positions.



- 0: Off
- 1: Front sidelights on.
- 2: Front sidelights and dipped/main beam on (depending on the position of the steering column switch).
Dipped or main beam operates only with the main switch and ignition on.

Corner light (optional)

Functioning of the corner light is only possible when the vehicle lights are switched on.

At normal driving situation on a straight road the corner light is switched off.

When turning a corner (direction indicator) or slow driving at a curvy road (at a speed up to 20 km/h) the concerned corner light will automatically switch on.

When selecting reverse gear, both corner lights will also switch on as a parking aid.

E. Front and rear fog lights

The switch has three positions.



- 0: OFF
- 1: Front fog lights on
- 2: Front-, and rear fog lights on

Fog lights can only be switched on when front sidelight or dipped-, or main beam is on.



Switching off the main switch switches off the rear fog lamp, and the fog lights switch must be reset before the rear fog lamp can be switched on again.

F. Option

This position is not in use and can, therefore, be used to operate an optional instrument or accessory.

G. Electrically operated driver's side window

To open or close the driver's screen, the switch must be pressed on the top or the bottom side.



H. Electrically heated driver's side window

Simultaneous switching on and off of the driver's window and/or window in service door.



The light in the switch will be brightly lit when this function is in use.

I. Driver's ventilation fan

Turns the driver's ventilation fan on and off.



J. Hostess ventilation fan

Turns the hostess' ventilation fan on and off.

K. Reversing buzzer

Switching on/off a buzzer when driving in reverse.



L. Electrical roller blind

To open or close the left hand sun blind, push respectively the upper or lower part of this switch respectively.



M. Electrical roller blind

To open or close the right hand sun blind, push the upper or lower part of this switch respectively.



N. Ferry lift/rear kneeling

For the operation, see "Ferry lift/front kneeling".



O. Ferry lift/front kneeling

There are two ways of temporarily changing the coach level by pneumatic suspension, making it either higher or lower than the neutral driving level. The temporary high adjustment is usually used to obtain more ground clearance for, e.g. boarding ferries. Adjusting downwards makes it easier for passengers to board.



Operation and use

If the pneumatic suspension is not in the neutral position this is indicated in both cases by the illumination of the yellow ECAS symbol in the display.

If the pneumatic suspension is not in the neutral position the warning light on the switch is illuminated.

2

- 0: Raising (front and rear)
- 1: Driving position (neutral)
- 2: Kneel (front)



If the vehicle is equipped with a lift for disabled people or with standing places, the vehicle speed is limited to 5 km/h when the vehicle is kneeled.



If the vehicle is not in the neutral position, the maximum vehicle speed may not exceed 5 km/h.



The ECAS system switches automatically to driving (neutral) position above 20 km/h, and switches in again if the speed falls below 5 km/h.

P. Switching on and off of the optional wheelchair lift.



This option will only function when main switch and parking brake are on.



If the vehicle has a trailing axle: ensure, before opening the lift door, that the trailing axle is in the straight-ahead position.

Q. School bus warning lights

The vehicle can be equipped with school bus warning lights as an optional extra. When the door is opened, the warning lights are turned on automatically. This function can be turned off using this switch.



R. Right/fixed trailing axle wheels

This switch is used to place the trailing axle in the straight-ahead position and to lock it in this position. This can be useful in particular manoeuvres at speeds below 30 km/h.



This switch may also be of assistance on extremely slippery roads.

If this function is turned on, the red warning light in the switch will be lit.

S. Trailing axle relief

If, under extreme conditions, the grip of the driven wheels is not sufficient for the vehicle to pull away, this switch can be used to temporarily relieve the trailing axle (maximum 3 tons). As a result, more pressure will temporarily be placed on the driven wheels.



The trailing axle relief lasts for 80 seconds. If it is necessary to relieve the trailing axle again, you will have to wait at least 50 seconds before the system reacts again. This is due to legal requirements relating to the maximum axle loading.

If this function is turned on, the red warning light in the switch will be lit.

T. Easy start off

The vehicle is equipped with an electronic starting device (easy start). For more information, see [Pulling away with starting assistance](#) (📖 47).

U. Select

To go through the various functions and menu's in the



display, push respectively the upper or lower part of this switch.

Upper part means one position forward, lower part means one position backward.

 **By using the emergency switch, it is not possible to meet the electrical system's switching off conditions. This may have serious consequences for various electrical systems in the vehicle. Therefore, only use the emergency switch in the event of an emergency.**

 **The emergency switch can also be used to reset the electrical system.**

For this, you have to turn off the contact switch and the main switch. Wait at least 2 minutes after turning off the contact switch to enable the EAS system to shut down.

Use the emergency switch to turn off all the electrical consumers, with the exception of the hazard warning lights, the pre-heater and the tachograph.

V. Activate

This switch accesses menu 1.

Next by pushing this switch the, with the select switch, chosen function can be activated.



9. Engine brake

The engine brake may be used during prolonged braking, for example during descents or when braking from high speeds.

Depressing the engine brake operating knob provides extra braking via the engine. Fuel injection is reduced and the butterfly valve in the exhaust system is closed.

This reduces brake wear.

The additional power declines as the engine speed falls.



The engine brake does not function at engine speeds below 700 rpm.

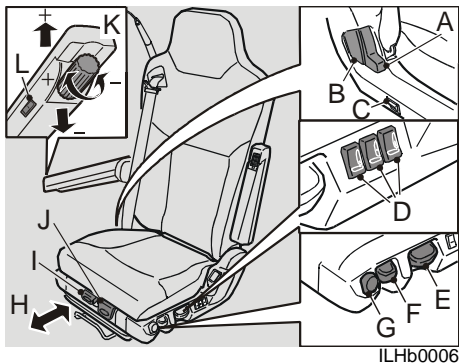

ILHb0006

10. Driver's seat

 Set the seat in the desired position before starting to drive.

A: Shoulder adjustment

Pull the lever upwards and adjust the shoulder to the desired position.

B: Seat back adjustment

Pull the lever upwards and adjust the seat back to the desired position.

C: Seat heating

Switch on/off the seat heating.

D: Lumbar support adjustment

The air-cushion in the seat back can be filled (+) or emptied (-) by pushing on the top or bottom of the knob.

E: Seat height adjustment

Push or pull the handle up or down to adjust the seat to the desired height. The seat is adjustable over a range of 100 mm.

F: Vibration dampers

Raise the lever (Seating comfort "soft"), Press down the lever (Seating comfort "hard").

 The vibration damper must always be set so that it offers enough resistance on a poor road surface, so that the driver will not lose contact with the pedals.

G: Quick lowering

Push the handle downward until the seat is lowered to its lowest position. (Useful when getting in or out).

When the handle is returned to its previous position, the seat returns to its former height.

H: Fore and aft adjustment

Pull the handle up and adjust the seat to the required position. The seat is adjustable over a range of 180 mm.

I: Adjusting the seat lengthways

Pull the handle upwards and adjust the seat to the required position.

J: Adjusting seat inclination

Pull the hand lever upward to place the seat in the desired position. Releasing the hand lever locks the seat in position.

K: Armrest adjustment (optional)

The knurled knob at the front can adjust the inclination.

L: Hands-free phone/microphone switch (optional)

Switches on/off the microphone/hands-free phone.

11. Clutch pedal

For an explanation of how to use the clutch, see [Gear shifting](#) (📖 46).

2

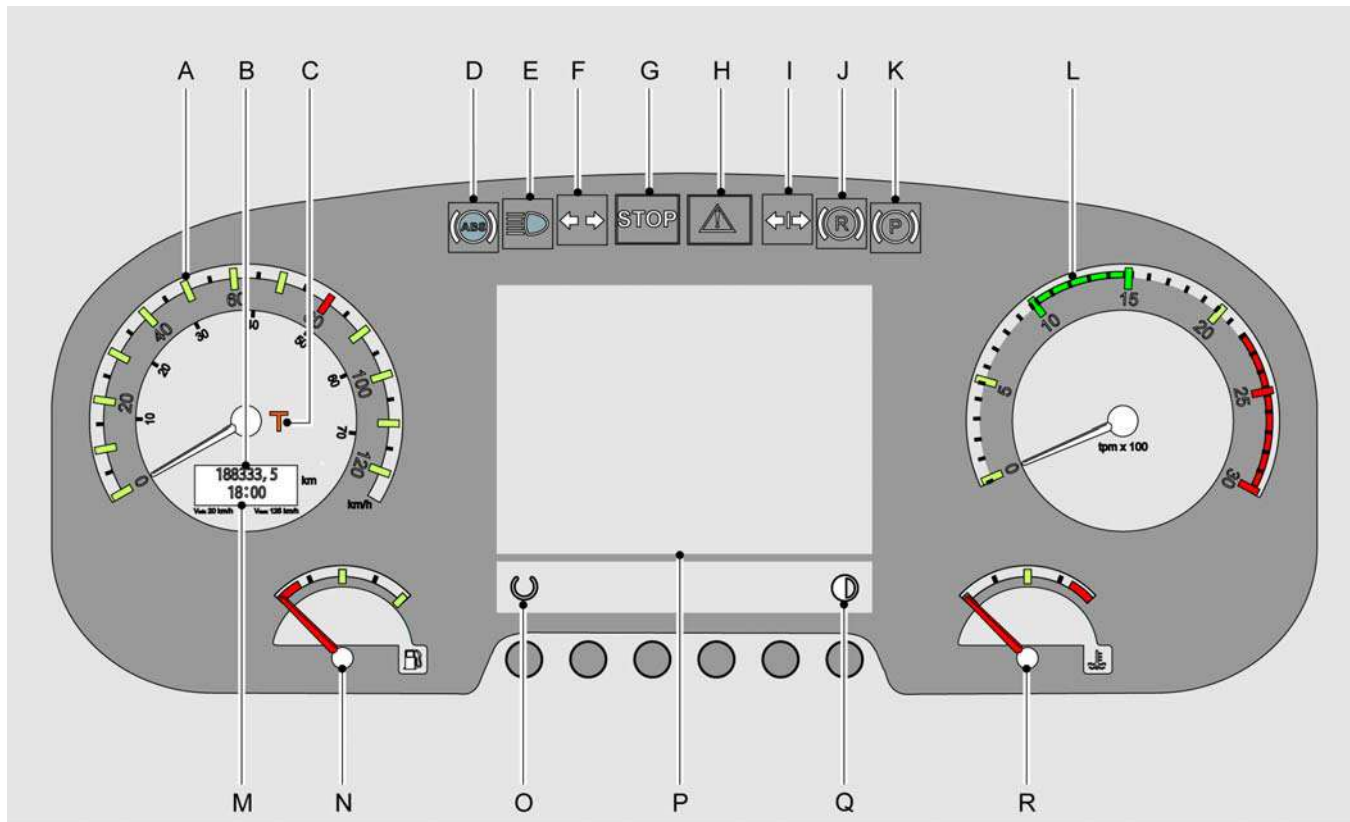

ILHh0011

12. Instrument panel

A. Speedometer	37
B. Odometer	37
C. Tachograph warning light	37
D. ABS warning light	37
E. Main beam warning light	37
F. Indicator warning lights (green)	37
G. Priority warning 1	37
H. Priority warning 2	37
I. Trailer indicator warning lights	37
J. Retarder warning light	37
K. Parking brake warning light	38
L. Rev counter	38
M. Clock/trip meter	38
N. Fuel gauge	38
O. Switching between the clock and the trip meter	38
P. display	38
Q. Brightness adjustment	38
R. Coolant temperature gauge	38

General information

If the ignition is switched on while the main switch is on, all the warning lights will be lit for 3 seconds, with those that are active remaining on.

The fuel gauge and coolant temperature indicators go to maximum and then return to show the current reading.

A. Speedometer

The speedometer inner ring gives the speed in mph, the outer ring shows km/h.

B. Odometer

The odometer records the distance travelled.

C. Tachograph warning light

This lamp is illuminated when there is a fault in the tachograph, or when other problems occur, such as the absence of a tachograph disk.

D. ABS warning light

This lamp lights up when the main switch and ignition are switched on. The light should go out after a few seconds.

E. Main beam warning light

When the main beam is on, the blue indicator lamp is illuminated.

Selection between main and dipped beam is via the left hand combination switch on the steering column.

F. Indicator warning lights (green)

When the left or right indicators or the hazard warning lights are switched on, the indicator warning lights flash with the same frequency.

If one of the external indicator lamps fails to flash, the warning light flashes only once.

G. Priority warning 1

If this warning light is lit in combination with a fault symbol on the display, the vehicle must be brought to a standstill as quickly as possible and the engine must be turned off (see [Messages on the display](#) (📖 50)).

H. Priority warning 2

If this warning light comes on in combination with a fault symbol on the display, there is a problem that must be solved as soon as possible, but the vehicle may be driven to the next available stopping place, see: [Messages on the display](#) (📖 50).

I. Trailer indicator warning lights

These lamps operate when the indicator lamps are switched on and a trailer is in use.

J. Retarder warning light

This lamp lights up when the retarder operates.

The brake lights also operate.

K. Parking brake warning light

When the parking brake is operated the warning light will come on and the rear wheels will be locked.

L. Rev counter

The revolution counter has 4 regions:

Left hand region:	Very economical
Green:	Economical.
Middle region:	Less economical.
Red:	Avoid

M. Clock/trip meter

The clock shows the time and can be set by setting the tachograph clock.

Pushing knob (O) switches to trip meter allowing distance travelled to be measured.

N. Fuel gauge

The fuel gauge operates only when the ignition is on, and shows the fuel level in both tanks.

A warning symbol is illuminated in the display when the fuel in the tanks falls below the reserve level.



There is approximately 40 litres of fuel remaining.

O. Switching between the clock and the trip meter

Switching between clock and trip meter. The trip meter can be reset to zero by pushing the knob in longer.

P. display

The display normally shows the driver menu. For instructions, see [Display \(📖 54\)](#).

Q. Brightness adjustment

The brightness of the display can be adjusted to personal preference.

R. Coolant temperature gauge

Do not over exert the engine when the coolant temperature is below 50 °C.

The engine is at operating temperature when the temperature gauge is vertical or slightly further.

The warning symbol in the display is illuminated when the temperature rises above 110 °C.

The red field of the gauge starts at 0 °C.

If the coolant temperature suddenly rises and/or the pointer is in the red field, the following points should be checked:

- Coolant level, see: [Coolant level \(📖 90\)](#).
- Poly V-belt and water hoses.
- Cooling fan.

13. Steering wheel adjustments

The steering wheel and steering column may be placed in the desired position by operation of the knob.

The steering column is locked when the pressure switch is released.



Adjusting is only possible when the parking brake is applied.

14. Brake pedal

For an explanation of how to use the brakes, see [Braking \(📖 11\)](#).

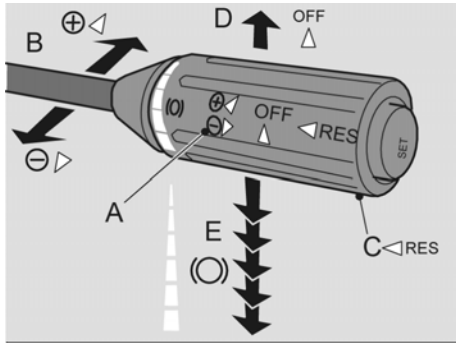

ILHh0012

15. Right-hand combination switch

A. Cruise control



Cruise control can only be engaged when vehicle speed is above 30 km/h.

The cruise control can be set to the current speed by moving the combination switch towards or away from the steering wheel.



Only use the cruise control when traffic conditions permit a steady speed. Do not use the cruise control in busy traffic, on roads with many bends or on slippery surfaces.

B. Acceleration/deceleration

If a different speed is required to that set, moving the switch briefly towards the steering wheel will raise the speed by 1 km/h.

The speed can be increased smoothly by holding the switch in the raised position.

Moving the switch away from the steering wheel allows deceleration in the same manner.

The vehicle speed may also be increased with the cruise control switched on by depressing the accelerator.

C. Cruise control memory function

By pressing the "RES" button (C) the cruise control is re-engaged at last set speed used. If the current vehicle speed is lower than this speed, the cruise control will attempt to accelerate the vehicle speed to the last set speed.

D. Turning off the cruise control

Cruise control is switched off by moving the switch forwards.

The cruise control is also switched off if:

- The parking brake is released.
- The parking brake is applied.
- The retarder is operated.
- The clutch is operated.
- The engine brake is operated.
- Neutral.

E. Bremsomat (downhill speed control)/ Retarder (Not if automatic gearbox)

The switch has 5 positions to the rear.

Position 1: Bremsomat

When driving downhill at the desired speed, the vehicle speed can be held constant at this value by putting the switch in position 1. The retarder determines the necessary braking force. If the braking force needed is greater than the maximum capacity of the retarder it must be supplemented by use of the engine brake or footbrake.



The Bremsomat will be set to the new speed when accelerating using the cruise control or the accelerator pedal, or when slowing down using the footbrake, the engine brake or one of the retarder settings.

Positions 2 to 5: Retarder

Selecting between positions 2 to 5 allows you to switch between 4 different retarder braking forces. This can also be done whilst driving. The retarder light on the instrument panel constantly gives the driver information about the present situation. Operation of the retarder will be interrupted during ABS activity, but resumes afterwards.

The retarder also operates during operation of the footbrake pedal.

The engine brake can be used to supplement the retarder.

 **Ensure that, during hill descents, the engine speed does not fall below 1,600 rpm, as this reduces cooling, which in turn reduces the effectiveness of the retarder (does not apply to vehicles with an AS Tronic or automatic gearbox).**

Where necessary, a lower gear should be selected to raise the engine speed and,

thereby, increase both the cooling capacity and the effectiveness of the retarder.

Safety instructions

The retarder should be used very cautiously on wet or slippery road surfaces.

The retarder operates on the driven axle only.



The vehicle may skid.

Switch off the retarder on very slippery surfaces, to avoid faulty operation see: [Vehicle functions \(📖 59\)](#).



During hill descents, operate the retarder with hand control only, not the foot control.

If the effect of the retarder is insufficient, it may be supplemented with the engine brake or the service brake.

Hand gas

Hand gas may be selected when the vehicle is stationary whilst the handbrake is applied and the automatic gear lever is in neutral.

Pressing "SET" causes the stationary engine speed to be increased to 800 rpm. By pressing "SET" twice, the stationary engine speed will be increased to 1,200 rpm.

By pressing "Set+" or "Set-", the rpm will be increased or decreased by 25 rpm.

By pressing "Set+" or "Set-" continuously, the idle engine speed can be infinitely set between the idling speed and the maximum engine speed (2,000 rpm).

Hand gas can be switched off by placing the control lever in the "off" position.

Hand gas also switches off when the brake pedal or accelerator pedal are depressed, or when the retarder or parking brake are applied.

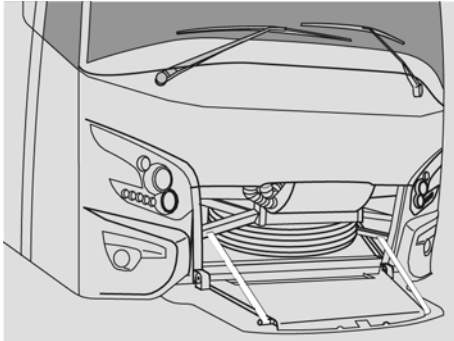

ILHa0008

16. Spare wheel compartment handle

The spare wheel compartment is unlocked by pulling on this handle.

The spare wheel compartment is retained by a catch.

Removing this catch allows the spare wheel compartment to be fully swung down.

The spare wheel and the towing eye attachment are located in this compartment.



The spare wheel compartment handle may not be pulled during a journey.

Switches with no fixed location

The switches described below are associated with optional equipment which may be installed. These components may be found in a variety of locations on the dashboard, depending on customer's and national requirements and the number of options installed.

Destination indicator lighting

This switch operates the destination/route lighting.



Top lights

Switching the extra top lighting off and on.



AV switch



Message box above driver

This switch operates the message box with stop message above the driver.



Message box above driver

This switch operates the message box above the driver with the seatbelt message.



Panoramic camera

Switching on a camera with a panoramic view.



Laptop connection



Wireless pin microphone



AV switch for video/DVD player

Switches on the 24 V DC to 220 V AC transformer.



17. Ventilation grilles

The direction of the ventilation grilles can be altered to suit personal preference. Turning the knob on the ventilation grille to zero closes the grille.

18. Audio

See the manufacturer's documentation for further detail on the operation of the audio system.

19. Tachograph

DTCO (Digital tachograph)



The DTCO tachograph saves an error code if the power supply is turned off or the battery is empty. In some countries, the error code is interpreted as a breach of the law. To prevent the unit from saving an error code when disconnecting the battery cables, place a DTCO workshop card in the unit whilst the battery is disconnected.

If an error code is saved, contact a recognized DTCO workshop to calibrate the DTCO and to delete the code.

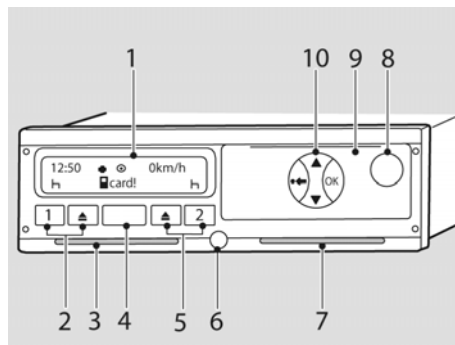

ILHh0022

1	Display
2	Operation driver 1
3	Card reader 1
4	Connection for calibration and download apparatus
5	Operation driver 2
6	Sealing
7	Card reader 2
8	Button for opening printer drawer
9	Printer
10	Menu selection buttons

If DTCO: See the supplier's documentation for the operating instructions.

20. Cup holders

The cup holders are located in the dashboard. The cup holders can be used by pulling them forwards.

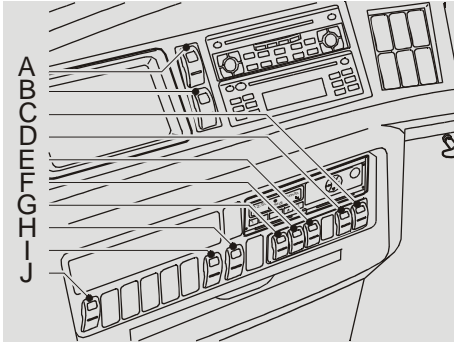

ILHh0037

21. Central dashboard switches

A. Hazard warning lights	43
B. Emergency switch (depending on national regulations)	43
C. Open/close the passenger door	43
D. Open/ close the central door	44
E. Lighting for the driver's compartment and the passengers' compartment	44
F. Interior lighting	44
G. Passenger reading lights	44
H. Luggage compartment (left) unlocking	45
I. Unlocking the luggage compartment (right)	45
J. Via monitors	45

A. Hazard warning lights

Operation of this switch makes the vehicle's indicators flash simultaneously. The hazard warning system can be used even if the main switch and ignition switch are off. The lamp in the switch is red and flashes. If the main switch is on, then the green direction indicator warning lamp on the instrument panel also flashes.



Legal requirements on the use of hazard warning lights vary from country to country.

B. Emergency switch (depending on national regulations)

In the event of an emergency, all electrical consumers will go off, with the exception of the hazard warning lights, pre-heater and the tachograph (if applicable in the location).



By using the emergency switch, it is not possible to meet the electrical system's switching off conditions. This may have serious consequences for various electrical systems in the vehicle. Therefore, only use the emergency switch in the event of an emergency.



The emergency switch can also be used to reset the electrical system.

For this, you have to turn off the contact switch and the main switch. Wait at least 2 minutes after turning off the contact switch to enable the EAS system to shut down.

Use the emergency switch to turn off all the electrical consumers, with the exception of the hazard warning lights, the pre-heater and the tachograph.

C. Open/close the passenger door

This switch is used to open the passenger door. The red light in



the switch will also be lit. Use the switch again to close the door.

The door has a safety feature so that it immediately re-opens when the contact strip meets an obstruction during closing.

 If the pneumatic system is blown off, the **Connecting the vehicle to an external air supply (19)** procedure must be followed in order to ensure that the door system functions correctly.

D. Open/ close the central door

This switch is used to open the central door. The red light in the switch will also be lit. Use the switch again closes the door.



The door has a safety feature so that it immediately re-opens when the contact strip meets an obstruction during closing.

 **The central door will not operate if the driver's sleeping compartment hatch to the side of the central door is not properly closed.**



If the pneumatic system is blown off, the **Connecting the vehicle to an external air supply (19)** procedure must be followed in order to ensure that the door system functions correctly.

E. Lighting for the driver's compartment and the passengers' compartment

The switch has three positions.



- 0: Off
- 1: Courier lighting on.
- 2: Courier lighting and driver's compartment lighting on

These lamps are also illuminated when the door is opened.

F. Interior lighting

The switch has three positions.



- 0: Interior lighting off
- 1: Night illumination on

- 2: Night light and strip lighting on



It is advisable not to leave the interior lighting on for more than 10 minutes with the engine stopped, because of high current consumption.

G. Passenger reading lights

The switch has two positions.



- 0: Night lights and passenger reading lights off.
- 2: The reading lights above the passengers' head, the hostest call buttons and the stop buttons (optional) can only be used when the driver has released them using the passenger reading light switch. After being released, the buttons in question will be lit.



The driver can also use this switch to extinguish all reading lamps simultaneously.

H. Luggage compartment (left) unlocking

Operation of this switch unlocks all left hand side luggage flaps and switches on the luggage area lighting.



The luggage hatches lock automatically when the main switch is turned off.



The luggage compartment lighting will turn off automatically whilst driving.

I. Unlocking the luggage compartment (right)

Operation of this switch unlocks all right hand side luggage flaps and switches on the luggage area lighting.



The luggage hatches lock automatically when the main switch is turned off.



The luggage compartment lighting will turn off automatically whilst driving.

J. Via monitors

This switch makes it possible for images to be shown on the vehicle's monitors. It is standard to have one switch for one system. It is possible to have a number of these switches fitted to display the images from a number of systems.



22. Navigation system

For a detailed description of the traffic navigation system, see the manufacturer's information supplied.

23. Refrigerator

The refrigerator has a capacity of 56 litres or 74 cans. It is also suitable for food. The temperature is controlled by thermostat, and is adjusted by turning a knob.

24. Accelerator pedal

For operating the accelerator pedal.

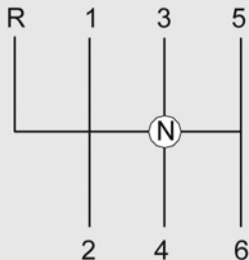

ILHc0019

25. Gear shifting

GO-210-230 gearbox

A GO gearbox can be optionally fitted. The type of gearbox depends on which engine the vehicle has.



The engine cannot be started when the gearbox is not in neutral.

Pulling away in first gear.

Preferably keep your revs between 600 and 800 min-1. Do not push the accelerator pedal whilst driving on a flat road. Don't go beyond 1,000 min-1 in 1st and 2nd gear. In other words, make sure the rev counter remains in the green section! Modern

engines have almost 100% of the torque at an engine speed slightly higher than the idling speed. In other words, stay in the green area. Thanks to the high torque of modern engines, the vehicle can pull away at an almost stationary engine speed when the vehicle is fully loaded! This prevents fast wear of the clutch.

In order to avoid fast wear of the clutch plate and the clutch pressure group we strongly advise you when shunting this vehicle only to use the lowest gear. The gearbox is synchronized, so do not use the double declutch method.



Incorrect changing of gears may damage the engine or the clutch. The gearbox may only put in reverse when the vehicle is at a complete standstill. When changing down gear, always make sure the speed is not too fast for the gear being changed into.

ZF AS Tronic automatic gearbox

Optionally a ZF AS Tronic gearbox can be applied. This gearbox is equipped with an integrated retarder (see [Vehicle functions](#) (book 59)).

The ZF AS Tronic is a fully automatic changing gearbox with automatic clutch control, which eliminates the need for a clutch pedal.

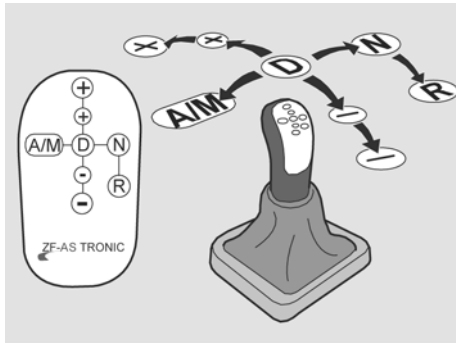

ILHc0020

+	Upshift 2 gears (spring point stop)
+	Upshift 1 gear (first spring point)
A/M	Change over from Automatic mode to Manual mode (and vice versa)
D	Driving
N	Neutral.
R	Reverse
-	Downshift 1 gear (first spring point)
-	Downshift 2 gears (spring point stop)



Whilst starting the engine, the range selector must be in the N (Neutral) position. Moving the range selector from R to D and visa versa, may only be undertaken when the vehicle is at a standstill.

Shifting

- Apply the service brake.
- Move range selector from “N” to “D” or “R”.

If one tries to switch over to D or R without engaging the service brake the message BP (Brake Pedal) appears in the display. The gearbox will still be in neutral.

To switch in after all:

- Move range selector back to “N”
- Apply the service brake.
- Move range selector from “N” to “D” or “R”



The driver is not allowed to leave the vehicle whilst the engine is running and a gear has been selected (selector lever in D or R)! The vehicle can be moved by releasing the brakes and simply depressing the accelerator. In order to prevent the vehicle from accidentally rolling forward, the service brake or parking brake must be applied.

The fully automatic mode (A) or the manual mode (M) is selected by moving the gear lever in the “A/M” direction. It is possible to change the mode at any time,

even when the vehicle is moving. It is not necessary to change the position of the accelerator pedal when switching modes. In the full automatic position, clutch and gear control are operated electronically and the engine will operate in the most economical area.

In case of manual operation, each intended gear change is checked by the electronics and if necessary, is ignored to prevent misuse of the driveline. The display of the AS Tronic shows to the driver all important system information, such as: neutral position, current gear, clutch overload or any faults in the system (see [Explanation of AS Tronic messages](#) (📖 56)).

Pulling away with starting assistance

The vehicle is equipped with an electronic starting device (easy start). Its purpose is to prevent unintended moving of the vehicle during uphill or downhill dead starts.

The Easy Start function keeps the service brake applied for a short period after it has been released.



Once the brake pedal has been released, the brake will only remain applied for a short period of time. The vehicle can start moving.

The time at which the brake is released depends on the position of the accelerator pedal, the position of the clutch and the vehicle speed.

The brake is also released if the gearbox is shifted into neutral or if neither the brake pedal nor the accelerator pedal are depressed within a certain time period.

Switching off starting device

When switching on the contact switch, the starting device is switched on automatically.

When the vehicle speed is < 30 km/h, the electronic starting device (easy start) can be switched off using this switch.



This can be useful when manoeuvring or driving at low speeds, in a traffic jam or during city trips.

When operating the switch again or the vehicle speed increases to above 30 km/h, the starting-aid will be activated automatically.

Manoeuvring

First gear and R gear are provided as manoeuvring gear for very slow travel. In the manoeuvring mode, the vehicle (accelerator pedal) is more sensitive and the clutch activation differs from how it behaves in the normal mode.



Do not use the manoeuvring mode during traffic jams or at a slope of more than 10% as the continuously slipping clutch may lead to clutch overload in this position.

Activating manoeuvring mode:

By holding the selector lever in position A/M for a few seconds, the display will show MM. The manoeuvring mode will then be activated. By moving the selector lever to position R, the display will show RM. It will then be possible to manoeuvre in reverse.



Deactivating the manoeuvring mode

The manoeuvring mode can be deactivated by:

- again holding the range selector in position A/M.
- Operating the kick-down.
- switching up the gear selector.

The display will now show the selected gear.

If the gear lever remains in the A/M position for 3 seconds or more, then the letters "M or A" will be shown on the display. The letters "M or A" will disappear after a short time.

Clutch Protection

If there is a risk of the clutch being overloaded by several starting procedures being undertaken one after another in short succession or by crawling in too high a gear, the "CL" display appears.



Select an operating mode in which there is no risk of clutch overloading, for example:

- Accelerate vehicle (to close the clutch).
- Stop.

- Set off quickly in a lower gear



Despite the clutch being automated, the driver still has considerable influence on the clutch's service life. To keep clutch wear levels as low as possible, we would recommend always selecting the lowest gear possible when setting off.

AS Tronic messages

For an explanation of the AS Tronic messages in the display, see [Explanation of AS Tronic messages \(📖 56\)](#).

Gear changes in the automatic mode

All upshifts and downshifts are undertaken automatically.



The operating mode can be changed from manual to automatic at any time, even whilst the vehicle is being driven.

Whilst driving

Remove your hand from the selector lever whilst driving. Your hand may cause the selector lever to move to "neutral"



The driveline will be interrupted if a shift is made to neutral. If, at the same time, a screwdriver symbol appears on the display, stop immediately at a safe place and turn off the engine!

Start again (see [Shifting \(📖 47\)](#)).

Stopping and parking



The gearbox is set automatically to N (Neutral) after the engine has been turned off or has been idling for 3 minutes.



When the engine has been turned off, there is no direct contact between the engine and the axle. The vehicle can, therefore, start to roll. Apply the parking brake

26. Central storage compartment

The storage compartment is opened by folding it forwards and can be locked with a key.

27. Storage compartment behind the selector lever

There is a small storage compartment behind the selector lever. This can be locked with a key.

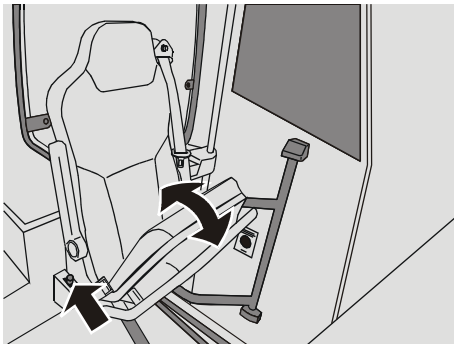

ILHb0001

28. Hostess seat

The seat can be folded upwards by pulling the handle next to the hostess seat backwards. When getting out of the seat, it will automatically fold up.

MESSAGES ON THE DISPLAY

General information

Operation of the main switch brings up the start-up screen and after 5 seconds the driving menu will appear.

Messages may appear on the driving display, which are divided into three priority levels.

When the engine is running priority 1 will appear together with a pulsing buzzing sound, and the illumination of the red stop symbol on the instrument panel.

Priority 2 is signalled by a 3 second buzzing tone and the illumination of the orange warning symbol on the instrument panel.

Priority 3: Status is indicated by the illumination of a symbol on the display.

If priority 1 or 2, automatically the driving menu will appear, no matter which menu was active on that moment.

Priority 1

There is an urgent problem which may give rise to risk of personal injury or damage to the vehicle.

This is signalled by a pulsing buzzing sound, and the illumination of the red stop symbol on the instrument panel.



Stop as soon as possible in a safe place and switch off the engine and ignition.

Trace the fault and correct it or have it corrected.

If the problem is corrected the buzzing and warning symbol will disappear automatically.



Warning
Coolant level too low.



Warning
Driver's sleeping compartment.



Safety warning
Luggage compartment
temperature high



Safety warning
Engine compartment
temperature high



Safety warning
Air pressure circuit 1 low



Safety warning
Air pressure circuit 2 low



Safety warning
Air pressure circuit trailing axle low



Warning
Coolant temperature high



Warning
Oil pressure too low



Warning
The oil level is too low.



Safety warning
ECAS fault (see: [Pneumatic suspension \(ECAS\) \(p. 67\)](#)).



Warning
Gearbox problem



Warning
DMCI motor management problem



Warning
The trailing axle is not functioning correctly (see [Instructions for driving with a trailing axle \(p. 70\)](#)).



Warning
Electronic Brake System problem (see [EBS system \(p. 116\)](#)).



Warning
Emergency valve front door / central door operated

Priority 2

There is a problem which may cause damage to the vehicle if not corrected early.

This is signalled by a 5 second buzzing tone and the illumination of the orange warning symbol on the instrument panel.



2

Stop at the first opportunity and switch off the engine and ignition.

Trace the fault and correct it or have it corrected.

When the problem is corrected the warning symbol disappears automatically.



Warning
Alternator 1 charging current fault



Warning
Alternator 2 charging current fault



Brake pad wear indicator
Brake pads front axle due for replacement



Brake pad wear indicator
Brake pads driven axle due for replacement

Operation and use

2



Brake pad wear indicator
Brake pads trailing axle due for replacement

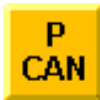

Warning
Power train CAN problem.



Warning
Vehicle CAN problem.



Warning
Low oil pressure



Warning
Low oil level



Warning
The oil level is too high.



Warning
DMCI motor management problem



Warning
Retarder fault



Warning
This symbol lights up when an error code has been recorded in one of the electronic units of the engine management system or the exhaust gas after-treatment system

 **The engine does not meet emission legislation requirements at that moment.**

If this warning is ignored automatic engine torque reduction may be expected.

See also [AdBlue legal minimum level](#) (📖 10)

 **The error codes can be read by the inspectors up to 400 days after they have been saved.**



Warning
Emission After treatment System (EAS) problem



Safety warning
Door system problem



Warning
Emergency hammer not in place



Warning
The trailing axle is not functioning correctly (see [Instructions for driving with a trailing axle](#) (📖 70)).



Warning
The trailing axle electronics or sensor are not functioning correctly. This may result in reduced functionality of the ESC system.



Fuel indicator
Fuel level is low



Warning
AdBlue level low



Warning
Gearbox problem



Warning
Electronic Brake System problem



Warning
Trailer Electronic Brake System
problem
This is lit in combination with the
red EBS light.



ECAS message (see
[Pneumatic suspension](#)
(ECAS) ([book 67](#))).



Warning
Starter motor protection
activated. Wait 15 minutes for
cooling down the starter motor



Warning
Cooling fan fault

Priority 3

Status is indicated by the illumination of a
symbol on the display.

You may continue to drive but check the
origin of the warning message and correct
it at the first opportunity.



No oil level measurement
possible (only displayed for 1
minute)



**Check the oil level using
the dipstick (see
[Manually checking the oil
level](#) ([book 88](#))).**



Sleeping compartment hatch
open



Door open
When front and/or central door
are open and the vehicle speed
is higher than 5 km/h this
symbol will appear in the
display.

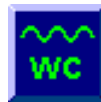

Drain tank is full



**Park the vehicle in an
appropriate place before
emptying the toilet.**

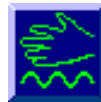

Fresh water tank for washing
hands is empty



Fuel pipe heating (Optional)



The symbol is lit when the ASR
system or the drag torque
control is active or when the
stability control intervenes



The symbol is lit when the ASR
increased slip control was
activated via the ASR switch
(see [Vehicle functions](#) ([book 59](#))).



The symbol lights up when the
retarder footbrake function is
switched off (see [Vehicle
functions](#) ([book 59](#))).



Hostess call operated by
passenger



Stop button operated by
passenger



Trailing axle relief

The load is relieved from the rear axle for 80 seconds. If you wish to relieve the rear axle again, it is necessary to wait for 50 seconds until the system reacts again. This is due to legal requirements relating to the maximum axle loading.



Wind screen heating

Switches off automatically after 15 minutes.



The symbol is lit when the toilet is occupied.



The symbol is lit when the front fog lights are turned on.



The symbol is lit when the rear fog light is turned on.



The symbol is lit when the Easy Start is turned off.



The symbol is lit when the reversing buzzer is turned off.

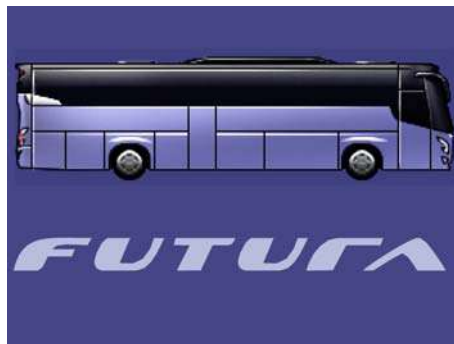

ILHh0042

DISPLAY

General information

Operation of the main switch brings up the start-up screen and after 5 seconds the driving menu will appear.

If from the driving menu another menu is chosen and there is for approximately 11 seconds no further operation, the driving menu will automatically open.

The various adjustments possible via the display are described in this section.

Selecting

To go through the various functions and menu's in the display, push respectively the upper or lower part of this switch.



Upper part means one position forward, lower part means one position backward.

Activating

Pressing this switch will access menu 1.



Next by pushing this switch the, with the select switch, chosen function can be activated.



ILHh0029

If the engine is running and there are one or more faults, then this will be shown by means of a symbol on the display (see [Messages on the display \(📖 50\)](#)).

A	Cruise control activated
B	Saved cruise control speed (± 1 km)
C	Bremsomat activated
D	AS Tronic activated gear messages
E	AS Tronic messages

Messages at the top of the display

In the upper bar the display provides information on the status of the transmission.

AS Tronic activated gear messages



Automatic mode/Manual mode To switch the operating mode from automatic to manual, push the tip lever to the left.



Manual mode To switch the operating mode from automatic to manual, push the tip lever to the left.



Transmission in neutral position



Reverse gear is engaged.



Which gear is selected in the gearbox

Explanation of AS Tronic messages



System "self-check". Display appears when contact is "on".



"Brake pedal". Before shifting first operate the brake pedal.



Warning information

"Airless" Alternates with the normal display. The transmission compressed air system has insufficient pressure.

⚠️ Only pull away once there is sufficient pressure in the pneumatic system. If the clutch doesn't open when stopping as a result of insufficient air pressure, the engine is "stalled".

⚠️ If the gear is changed whilst the pneumatic pressure is too low, the transmission may remain in neutral to ensure that there is no direct drive and to prevent the engine brake from being ineffective.



Warning information

"Accelerator pedal". Move the accelerator pedal to the stationary position. If the display does not go out, there is a system error. Further travel is not possible.

⚠️ If the accelerator pedal is depressed when starting the engine, the dashboard display will show the "FP" message and the vehicle will not select a gear.



Warning information

“Clutch” Alternates with the normal display. Clutch is overloaded. Select an operating mode in which the clutch will not be overloaded, for example:

- Accelerate vehicle (to close the clutch)
- Stop the vehicle
- Set off briskly in a lower gear

Even though the clutch is automated, the driver still has considerable influence on clutch service life. To keep levels of wear on the clutch low, we would recommend that when setting off, you always select the lowest gear possible.



Warning information

“Clutch Wear” Proceed to a recognized workshop to have the clutch exchanged at the next opportunity.



Warning information

“High temperature” (the transmission temperature is too high).



Warning information

“Electronic Error” Is displayed if the communication between the display and the transmission electronics is interrupted.



Warning information

“Easy Start” There is no temporary starting traction control.

The vehicle can start moving.



Warning information

“Neutral Shift” Set rotary switch to «N» Neutral.



Depending on the vehicle type, the transmission may automatically shift to neutral after a certain amount of time in order to protect the clutch’s mechanical components.



Warning information

“Clutch Check” The clutch position is unclear.



Warning information

“Transmission Check” The transmission position cannot be learned.



Warning information

“Selector lever” is in the “in between” position.

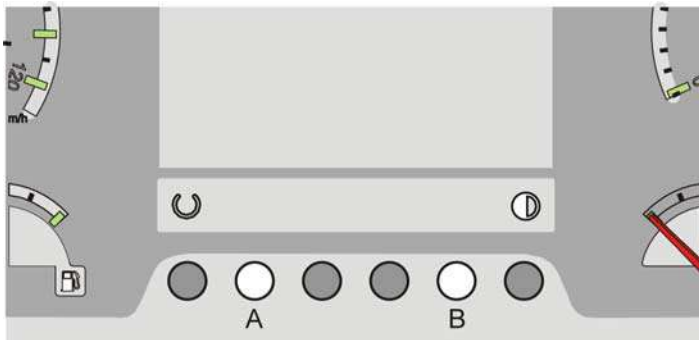

ILHh0038

Error menu

When entering the error menu one can on-board check which problem occurred.

The error menu can be opened when next conditions are fulfilled:

- Switch on main switch
- Switch on contact switch
- Apply parking brake

If one of the above mentioned conditions is no longer present, the error menu will be closed and the driving menu will be opened.

When pressing switch A and B at the same time the error menu will open.

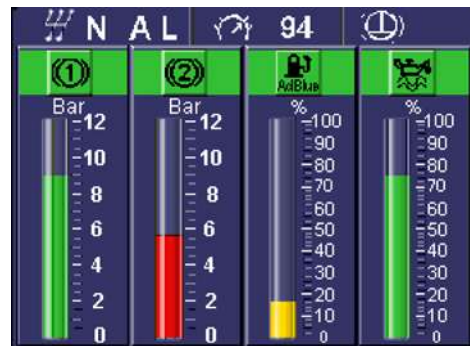

ILHh0027

Information menu

This display shows the air pressures in brake circuit 1 and brake circuit 2.

This display also shows the AdBlue level and the engine oil level (see [Engine oil level electronically \(87\)](#)).



If an “?” is given for the oil level, then this means that the oil level cannot be read. The oil measurement conditions have not been fulfilled.



ILHh0030

Vehicle functions

Vehicle functions and options can be switched on and off via this display.

- 1 Normally the retarder is switched on and is brought into operation by the initial movement of the footbrake pedal
This extends the life of the brake components

Operating this control knob switches off the retarder footbrake function.



- 2 The ASR system is always switched on, but operating this switch allows increased slip of the driven wheels before the system intervenes.

The ASR system prevents the driven wheels slipping both when moving off and when in motion, in order to obtain optimal traction and stability



- 2 Depending on the condition of the road surface, the ASR system reduces engine power and/or regulates braking pressure when excessive slippage is detected. On consistent road surfaces control will primarily be by means of reduced engine power.

The ASR symbol on the display will light up when the ASR system is in operation



⚠ Operation of the ASR system is an indication of slippery road surfaces.

- 3 Mirror heating is on by default when the temperature falls below 15°C
Mirror heating can also be switched on at temperatures above 15 °C by operating this control knob
- 4 Speed warning: If speed warning is activated for a particular speed, the driver is warned by means of a buzzer when this speed is exceeded.

2



ILHh0031

Vehicle functions 2

Vehicle functions and options can be switched on and off via this display.

- 1 Kitchen users: Operation makes it possible to use the kitchen equipment.
- 2 Navigation on monitors: Operation displays the navigation on the monitors in the coach.
- 3 WC/drain tank emptying
The WC/drain tank can be emptied by means of this switch. This can only be activated when the coach is not moving and the engine is switched off.

⚠ Empty only in a suitable location.

- 4 Wind screen heating
The wind screen heating can be switched on/off by means of this switch. The wind screen heating switches off automatically after 15 minutes.



ILHh0032

Vehicle functions 3

Vehicle functions and options can be switched on and off via this display.

- 1 Hostess call: After operation the passengers can use the hostess call switch in the personal setting units, see: [Personal service units](#) (📖 64).
- 2 If the temperature drops below -15 °C, the fuel pipe heating is switched on as standard, although it can also be switched on manually if temperatures are higher than -15 °C.
- 3 Bus stop: After operation the passengers can use the bus stop switch in the personal setting units, see: [Personal service units](#) (📖 64).
- 4 Invertor: Switching on the 24V DC to 220V AC invertor.
- 5 Vehicle lighting is on by default (Scandinavia)
Operating this control knob switches off the vehicle lighting.

Reversing camera (optional)

When switching over to reverse this display shows the view via the reversing camera.

Blind spot camera (optional)

If the vehicle's speed is below 35 km/h and the indicator at the hostess side is on, the display shows the view via the blind spot camera.

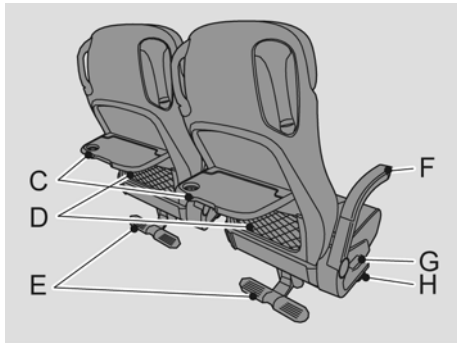

ILHb0000

PASSENGER COMPARTMENT

Passenger seats

The seats fitted in the vehicle may vary from those described here, depending on the chosen option.



Fit the passengers' seats using the correct torque.

- C Hinged table with space for drinking-glass.
- D Magazine rack

E Footrest, adjustable by moving first up, then down.

F Armrest, folds away by first moving it upwards and then downwards.

G Knob (on the walkway side) and handle (on window side) for back support adjustment.
The back support can be adjusted by 35° to 45° depending on the version fitted.

H Knob for sideways adjustment of the aisle side seat.

Also on the window side there are similar recesses. These are covered with aluminium covers that are fastened with tape: just pull to remove them. You can find these recesses (B) in the back and in the front of the coach and on the right hand side just in front of the rear rollover bar.

Passenger seat attachment nuts



In the rail necessary for the fixation of the seats there are recesses made to fit the fixation nuts.

In the floor these recesses are covered with removable pieces of rail.

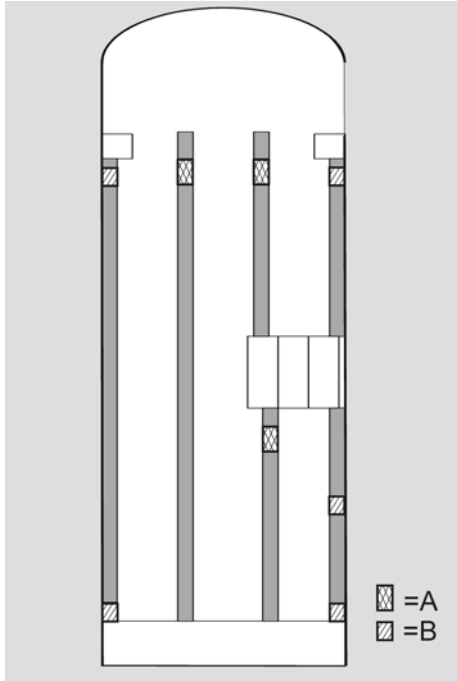
In order to remove or add extra fixation nuts, these pieces of rail must be removed. The drawing shows the spots where you can find these recesses (A).



ILHb0002

-  Recess floor (A)
-  Recess side wall (B)

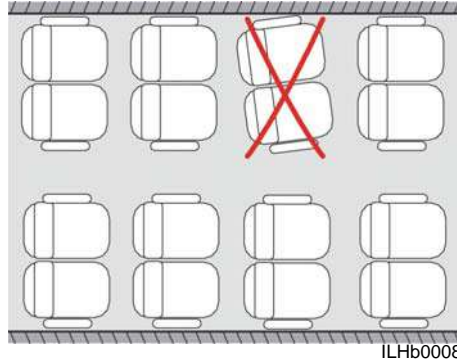

Seat attachment with quick-release system

Always align the seats at a right angle to the side wall.

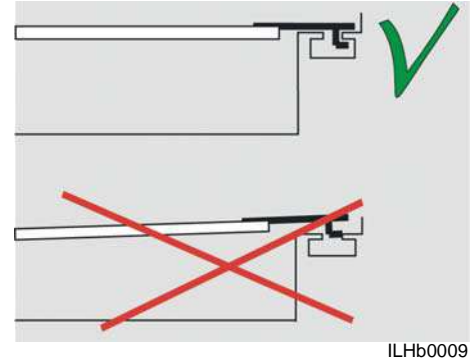

Always position the push rod correctly into the seat rail at the wall side.

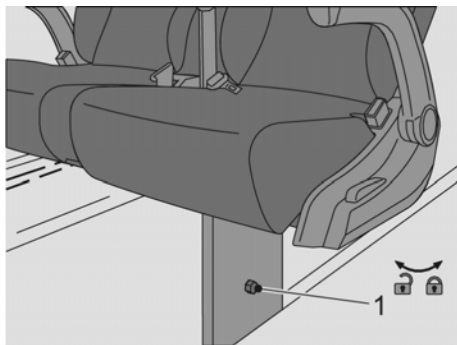

ILHb0007

Torques for passenger seat attachments

Quick-release connections	35 Nm (M10)
Gangway side	35 Nm (M10)
Side wall side	35 Nm (M8)

 **To prevent the construction from being overloaded, always observe the 35 Nm tightening torque for the quick-release bolt (1).**

 **It is no permitted to remove parts or to modify the quick-release system. It is also not permitted to apply oil or grease to the system or to the seat rail.**

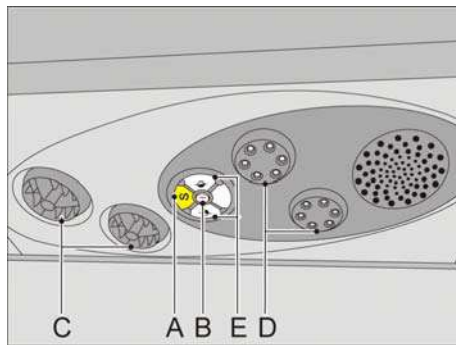

ILHb0003

Personal service units

A service unit is installed above each seat. Passengers can use these units to regulate the ventilation and to adjust the reading light to their personal preference. As an option, a speaker, stop and hostess call buttons can be fitted to each personal setting unit.

- A** The (optional) stop button can only be operated by the passenger when permitted in the display, see: [Vehicle functions 3 \(61\)](#). If the stop button is pressed, the stop symbol appears on the display and a buzzer sounds for several seconds. Opening the door resets this function.
- B** The (optional) courier call switch can only be operated by the passenger when permitted in the display, see: [Vehicle functions 3 \(61\)](#). When the hostess call button is pressed, the button above the passenger will change colour until the button is pressed again.
- C** The ventilator mouths may be turned to open or close them and also directed according to preference.
- D** Directional reading lamps.
- E** This button turns on the relevant reading light.

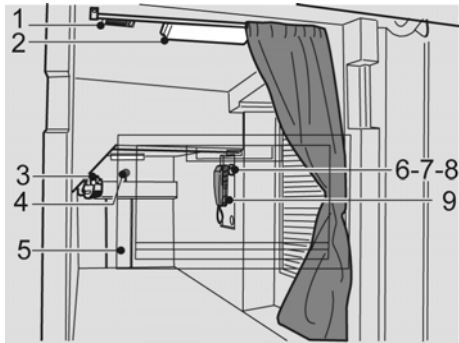

ILHz0010

DRIVER'S SLEEPING COMPARTMENT

General information

The driver's sleeping compartment is entered via the left or right luggage flaps or the roller shutter in the central entry.

1. Air outlets

There are air outlets on each side allowing fresh air supply. The air outlets may be turned to open or close them and also directed according to preference.

2. Reading lights

In the driver's sleeping compartment there are two reading lights which can be switched on or off by switch 8.

3. Heating (optional)

Heating of the sleeping compartment functions on the same circuit as the under floor heaters. Temperature can be adjusted by the thermostatic valve.

4. Emergency unlocking

When necessary the luggage flap can be unlocked from the inside by pulling the bar.

5. Sleeping compartment window

For ventilation purposes the window can be opened to the inside by pressing the knob and at the same time pulling the upper side of the window to the inside.

6. Ventilator switch

When the main switch is on, the extractor fan can be turned on or off using this switch.



7. Warning switch

Operation of this switch gives the driver a warning message on the dashboard



8. Lighting switch

When the main switch is on, the reading light can be turned on or off using this switch.

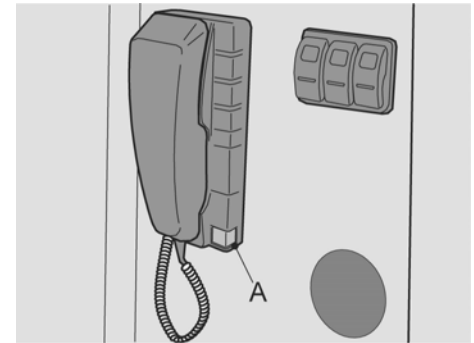

ILHh0028

9. Intercom installation

The intercom unit can be used to speak to the driver from the sleeping compartment and vice versa.

A call is made by pushing button A which sounds a buzzer in the other receiver.

When the receiver is taken one can speak to each other.

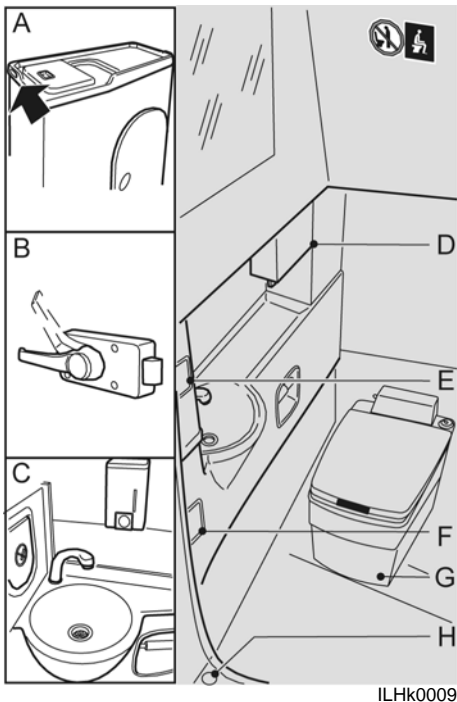

TOILET

General information

Depending on the chosen option, the toilet may differ from that described here.

The toilet air extraction operates continuously from the switching on of the contact switch.

- A: Occupied sign, which is illuminated when the toilet lighting is turned on with switch E.
- B: Lock, lockable from inside by moving the handle upwards, and from outside with a key.
- C: Sink with 70 litre reservoir. The tap is operated (with the knee) by switch (F). To the left of the sink is a waste bin fitted with a smoke detector.
- D: Paper towel dispenser
- E: Light switch for two halogen spotlights and the occupied light A.
- F: Knee-operated switch, for operating tap.
- G: Chemical toilet with level indicator, and flushing via a knob.
- H: Outlet, to allow water to drain away easily during cleaning.

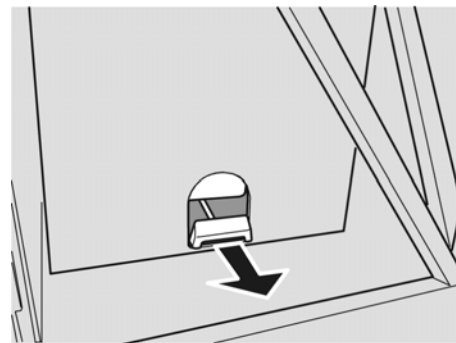

WC/drain tank emptying

Depending on the chosen option the WC/drain tank can be emptied by pulling the toilet slide which is accessible via the luggage compartment. An other possibility is by means of operating a switch, see: [Vehicle functions 2 \(📖 60\)](#).



Park the vehicle in an appropriate place before emptying the toilet.

KITCHEN

For a detailed description of the on-board kitchen see the manufacturer's information supplied.

NAVIGATION SYSTEM

For a detailed description of the navigation system see the manufacturer's information supplied.

PNEUMATIC SUSPENSION (ECAS)

The Electronically Controlled Air Suspension is operated via a microprocessor.

The vehicle height is stored in the microprocessor memory.

If the actual vehicle height is different, this is adjusted for automatically.

ECAS control symbols

Any disturbance to the ECAS system is reported by the illumination of ECAS symbols on the display, see: [Messages on the display \(📖 50\)](#).

If the red ECAS symbol flashes, then there is a serious fault.

- The level can not be checked or adjusted.

If the red ECAS symbol illuminates continuously in the driver menu there is a minor fault such as:

- No speed signal.
- The level can only be monitored to a limited extent.
- Low voltage, between 7.5 and 18 volts.
- Raising inoperative, regardless of valve position.

If the yellow ECAS symbol flashes in the driver menu, the storage pressure is too low.

If the yellow ECAS symbol is continuously illuminated, the level in question varies from the normal level: raising or kneeling required.

Raising/kneeling

The ECAS system is equipped to allow the whole vehicle to be raised, or to allow the front or rear axle to be kneeled separately. The capability to raise the vehicle may be used if more ground clearance is required, for example when boarding a ferry. The kneeling function may be used to allow passengers to alight more easily.

The front of the vehicle is raised or kneeled by means of the [Ferry lift/front kneeling](#) (📖 31).

Position 0: Raise (front)

Position 1: Driving position (neutral)

Position 2: Kneel (front)

The rear of the vehicle can be raised or kneeled by means of the [Ferry lift/rear kneeling](#) (📖 31).

Position 0: Raise (rear)

Position 1: Driving position (neutral)

Position 2: Kneel (rear)

Anti-tilt system

The vehicle can also be fitted with an anti-tilt system (obligatory in the UK).

Any vehicle can drive along a cambered surface at a certain angle. If this angle becomes too great, the vehicle will topple over.

The anti-tilt system increases the toppling angle by 5°. This means that the vehicle will not topple over so easily.

STEERING MECHANISM

The steering mechanism is hydraulically assisted.



In temperatures below 0 °C, it is recommended to run the engine for several minutes, after a cold start, before moving the steering.



Do not continue to turn the steering wheel when the wheels touch an obstacle or when they have reached the maximum turning angle. Doing so may damage the steering mechanism.

The turning angle is 60 ° and there are 6.8 turns from lock to lock



The vehicle can also be steered without the power steering, but this requires a large force.

MIRRORS

The mirrors are electrically heated and electrically adjustable. There are wide angle mirrors on the left (optional) and/or right.

The heating functions automatically but can be switched on manually (see [Vehicle functions](#) (📖 59)).

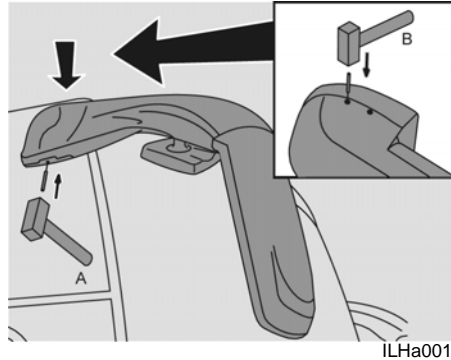

ILHa0011

Removing mirrors

The mirrors can be removed (e.g. when cleaning the vehicle in a car wash) using a hammer and the punch provided.

Place the punch in the bottom recess. Use a hammer to tap the punch into the mirror. Remove the punch from the recess. The mirror can now be removed.

Replacing mirrors

The mirrors can be refitted by hooking them in the attachment. Place the punch in one of the two recesses at the top. Use a hammer to tap the punch in the mirror (hit the punch 2 or 3 times).

Remove the punch from the recess. The mirror will now be secured in place.



If the mirrors do not vibrate and the adjustment operates correctly, this indicates that they are properly fitted.

INSTRUCTIONS FOR DRIVING WITH A TRAILING AXLE

Steering mechanism

2

On vehicles fitted with a trailing axle (second rear axle) the trailing axle wheels are steerable at vehicle speeds up to 30 km/h.

Driving the vehicle in forward or reverse gears the trailing axle will automatically steer. The steering angle of the trailing axle will be determined by:

- The sensors on the front axle which, up to 10 km/h, detect the steering direction of the front wheels and convert them to the vehicle electronics, which use this signals to actuate one of the locking cylinders of the trailing axle. By this the system prevents the trailing axle to steer in the wrong direction.
- The forces created between the tyre and road surface which takes care of the exact trailing of the trailing axle.



The trailing axle must be allowed time to return to the straight-ahead position. There should, therefore, be a delay of several seconds after selecting the forward or reverse gear before gently pulling away.



A slight movement of the vehicle may assist with straightening up the trailing axle wheels.

Automatic locking straight-ahead

To obtain more stable handling the trailing axle is locked in the straight-ahead position as soon as:

- Speed is above 30 km/h.
- ABS is activated.
- ASR is activated.
- Higher wheel slip is allowed.
- The trailing axle is temporarily unloaded.
- Malfunction in the system.

Manual locking straight-ahead

Whilst driving on loose ground or on a slippery road surface or using ferry lift the locking system can be activated by applying the straight ahead locking switch, see: [Right/fixed trailing axle wheels](#) (📖 32).



To eliminate tyre wear and decrease the turning circle, it is important to de-activate the manual lock as soon as possible and continue using the automatic system.

Fault in the trailing axle locking system

If the trailing axle fails to lock at a speed above 30 km/h, the red prio 1 warning light will illuminate.



The road handling of the vehicle will become unstable in these circumstances. It is possible to drive but only with adjustments to speed and with the greatest care.

If the trailing axle is not functioning correctly, the yellow prio 2 warning light will illuminate. A VDL Bus & Coach service point should be consulted as soon as possible to have the fault investigated.



3 SAFETY PRECAUTIONS AND EMERGENCY PROCEDURES

GENERAL INFORMATION	73
ROOF HATCHES	73
EMERGENCY OPERATION OF THE DOORS AND HATCHES	74
FIRE EXTINGUISHER	77
SEAT BELTS	77
FIRST-AID KIT	78
HAZARD WARNING LIGHTS	78
EMERGENCY HAMMERS	78
EMERGENCY PROCEDURES	79

GENERAL INFORMATION

Before departure, the driver should provide the passengers with adequate information about the emergency procedures and should also ensure that all the emergency exits are unobstructed.

In an emergency, the driver and/or the passengers may exit the vehicle via the doors, windows or roof hatches.

 **Before setting off on a journey, check whether the roof hatches are closed properly.**

ROOF HATCHES

The vehicle has two roof hatches. The front roof hatch is an emergency hatch and the rear roof hatch is a service hatch. The roof hatches have a ventilation position and can be used as an emergency exit.

 **A roof hatch must not be used to climb onto the roof for cleaning work.**

Ventilation position

The roof hatch can be opened fore and aft for ventilation purposes by pushing (A) to the outside. To re-close the hatch, pull (A) towards the inside.

The roof hatches may be in the ventilation position whilst driving the vehicle, but if only the front ventilation position is used, the vehicle may not be driven at a speed greater than 100 km/h.

 **When fitting the hatches, they must be locked with the aid of the handles (B). To enable this locking action you have to pull (A) firmly towards the interior!**

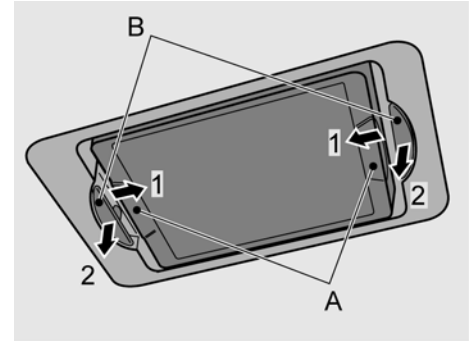

ILHz0012

Opening/Removing the emergency hatch

In the event of an emergency, the emergency hatch can be removed by first removing the protective covers (1) and then pulling the handles (2) in the direction of the arrow. The roof hatch can then be pushed outwards.

The hatch remains attached by a safety strap.

 **The emergency hatch can only be removed once and should, therefore, only be removed in the event of an emergency!**

3

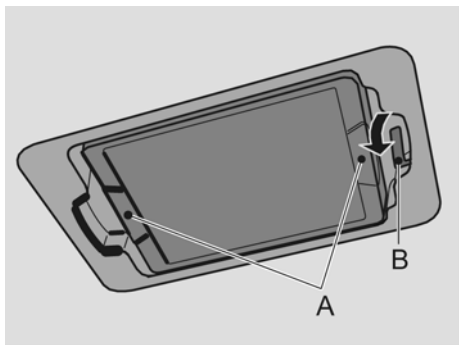

ILHz0006

Opening the service hatch

If handle B at the rear of the hatch is turned, the hatch can be opened by approximately 100°.

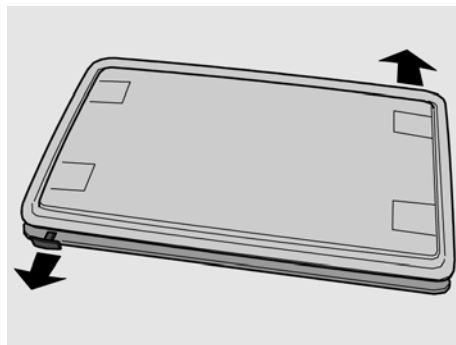

ILHz0013

Opening/Removing the roof hatches from the outside of the vehicle

In an emergency, the roof hatches can also be removed from outside the vehicle by pulling the handles.

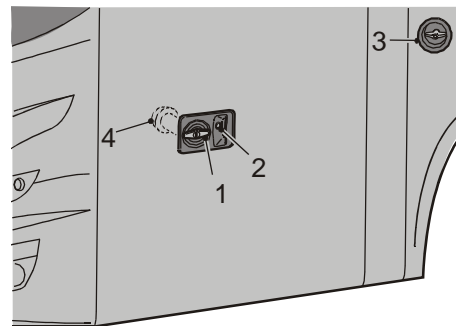

ILHa0000

EMERGENCY OPERATION OF THE DOORS AND HATCHES

Passenger door and central door

By turning the key the handle (1) can be locked/unlocked. By turning the handle the door is locked/unlocked.

The door is opened/closed with push button (2).

If the door is unlocked and the normal door operation is not functioning, the door can still be opened by turning the emergency handle (3), allowing the door to be opened by hand.

A buzzer sounds and the red lamp in the switch illuminates.

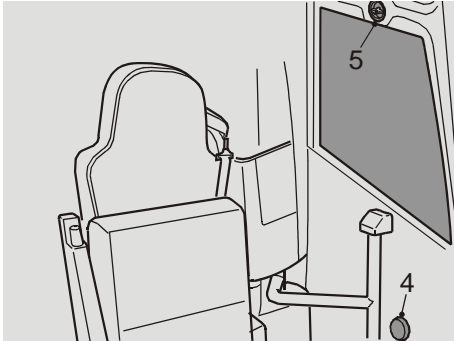

ILHi0008

In the case of an emergency, the passenger and central door can be opened from inside by operating the emergency handle (5) which depressurises the system allowing the door to be opened by hand.



If the door does not open, turn the knob (4) to unlock the door.

After resetting the door system (opening and closing the doors with the switch), the buzzer will turn off and the red light in the switch will go out.



If the pneumatic system is blown off, the procedure **Connecting the vehicle to an external air supply** (📖 19) must be followed in order to ensure that the door system functions correctly.

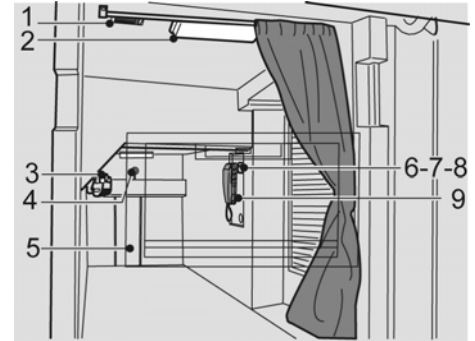

ILHz0010

Sleeping compartment hatch

The left-hand sleeping compartment hatch can be unlocked from the inside by pulling the bar (4). The hatch can then be opened. The right-hand sleeping compartment hatch can only be opened from the outside using a key (see **Luggage hatch emergency operation** (📖 76)).



When the middle door is open, only the left hand sleeping compartment hatch can be opened.

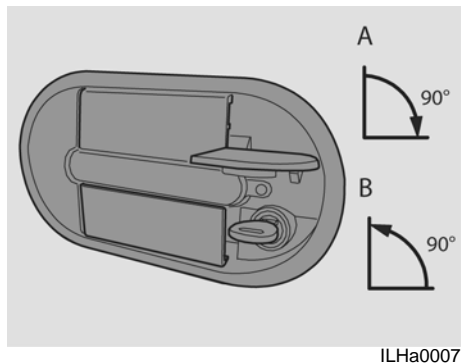
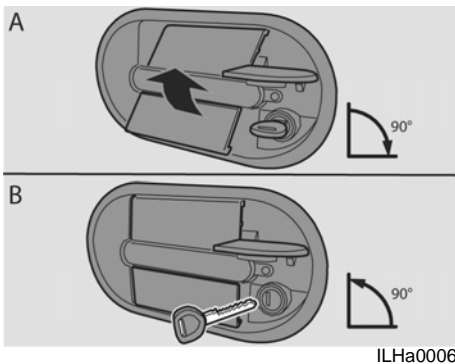

Before departing, always check whether the locking mechanism works correctly.

3

Luggage hatch emergency operation

If the luggage compartments and the driver's sleeping compartment cannot be unlocked using the switches on the dashboard, the compartments can only be opened by using a key.

- A Turn the key 90° to the right (leave the key in the lock). Open the flap by operating the rocker handle (key remains in the 90° position). Return the rocker handle to the neutral position (key remains in the 90° position).**
- B Return the key in the 0° position and remove the key.**

Resetting the luggage hatch lock

If, after an emergency operation, the lock does not catch in the lock plate, the lock can be reset.

Turn the key 90° to the right (A) and return the key in the 0° position (B) without operating the rocker handle.



When using a key to open a hatch, the central locking system will no longer function. To re-use the central locking system, first lock the hatch with the key.

FIRE EXTINGUISHER

The fire extinguisher is located in the passenger space on the floor to the left and/or right at the front. It has a pressure gauge for checking whether the fire extinguisher is still in good working order. Make sure the fire extinguisher is inspected at least once a year. If the fire extinguisher is used, it must be refilled as soon as possible.

SEAT BELTS

The driver's and hostesses seat are provided with triple point anchorage safety belts.

The passenger seats are provided with triple anchorage point safety belts.



A vehicle equipped with ESC may unexpectedly brake hard in certain situations. Therefore, always wear a seat belt.



It is your duty to ensure that the passengers use the safety belts properly!

Fastening

Insert the clip into its housing. When a clear click is heard, the belt is fastened. It is important for safety reasons that the belt fits snugly against the body.

The belt must not be crooked or twisted.

The hip belt must sit low (i.e. not above the stomach).

Unfastening

Push in the red knob on the housing.

Ensure that inertia reel belts are rolled up without the belt being twisted.

Inertia belt reel locking

Normally inertia reel belts are free to move. The belt locks because of:

- Pulling the belt out too fast.
- Braking and accelerating, and when the vehicle tilts excessively to one side.
- On bends.

Inspection

Check regularly that the belts are in good condition.

The locking function of an inertia reel belt can be checked by giving it a short tug.

The belt should lock and not be able to be withdrawn.

3

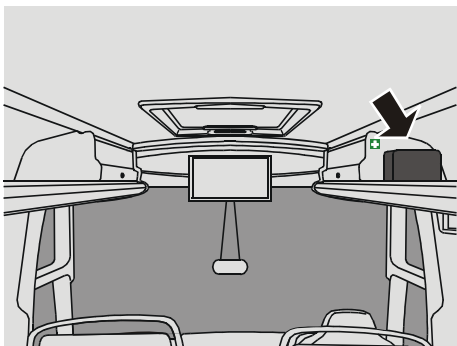

ILHz0009

FIRST-AID KIT

The first-aid kit is located in the luggage rack above the driver.

Ensure that you always have a complete first-aid kit (obligatory in some countries).



Replace any of the contents as soon as they are used.

HAZARD WARNING LIGHTS

The hazard warning lights must be used if you are forced to stop or park in a way that obstructs or endangers other traffic.

The hazard warning lights are turned on with switch [Hazard warning lights \(43\)](#).



Requirements for the use of hazard warning lights vary from country to country.

Hazard warning triangle/warning light

Place the warning triangle or warning lamp (in the toolkit) at least 30 metres behind the vehicle in case of danger.

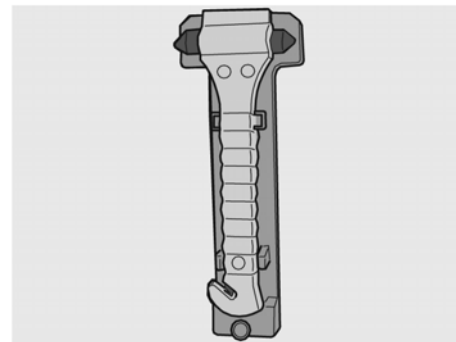

ILHz0001

EMERGENCY HAMMERS

In an emergency these hammers may be used to break glass or to cut through a safety belt.

The emergency hammers are located throughout the vehicle on the window stiles.

Break the lock and hit the sharp point against the window, preferably not in the middle of the window.



Take into consideration that the windows may be double glazed.

EMERGENCY PROCEDURES

Even a vehicle in good condition may be involved in an emergency, a breakdown or an accident. This almost inevitably leads to a dangerous traffic situation, since the vehicle may not come to a stop in a safe location.

The driver's actions immediately after an emergency has taken place can play an important role in limiting the consequences. Since emergency situations are very diverse, it is not possible to give a standard solution. However, there are often similarities, so that it is possible to give the following general rules:

- First ensure your own safety, then that of the passengers.
- Calm the passengers.
- Watch out for other traffic.
- Be careful where you stand and walk.
- Watch out for the release of hazardous substances.
- Act quickly and decisively, but remain calm and avoid panic reactions.
- Prevent accidents and the escalation of accidents.
- Ensure that other road users are warned by, for example, hazard warning lights, the vehicle's own lighting, the warning triangle or similar items.
- Switch off the engine and turn off the main switch.
- Prepare fire extinguishers and, if necessary, extinguish any fires which may break out.

If necessary, notify the emergency and rescue services.

Assist any injured persons.

4 MAINTENANCE

GENERAL INFORMATION.....	83
MAINTENANCE CHECKLIST	84
DAILY CHECKS/MAINTENANCE	87
WEEKLY CHECKS AND MAINTENANCE.....	91
OVERVIEW OF THE MONTHLY INSPECTIONS WHEN USING BIODIESEL	96
WATER SYSTEM.....	97
BEFORE THE WINTER	97
AFTER THE WINTER	99
EXTERIOR	99
TOUCHING UP PAINTWORK.....	100
INTERIOR MAINTENANCE.....	101

GENERAL INFORMATION

The durability, safety, depreciation and reliability of the vehicle is to a large extent dependent on the way it is cared for and on the regular performance of the maintenance prescribed by VDL Bus & Coach.

The driver's driving style and his care of the vehicle have a direct influence on the vehicle's condition.

The driver can often give the workshop information which is valuable for good maintenance.

The vehicle should be serviced according to the intervals given in the Futura FHD2 maintenance book. However, if the vehicle has to operate in dusty areas or under difficult conditions the frequency of maintenance should be increased.

The maintenance discussed here refers to activities the driver can carry out himself.

A checklist is provided listing the points to be covered by the driver.

MAINTENANCE CHECKLIST



Maintenance activities can be checked off on a copy of this list.

	Daily	Weekly
Engine compartment		
Possible oil, air or coolant leak	<input type="checkbox"/>	<input type="checkbox"/>
Check the engine oil level ^a	<input type="checkbox"/>	<input type="checkbox"/>
Check the AdBlue level	<input type="checkbox"/>	<input type="checkbox"/>
Check the fluid level of the hydraulic fan drive ^a		<input type="checkbox"/>
Check the coolant level ^a	<input type="checkbox"/>	<input type="checkbox"/>
Check the steering mechanism's hydraulic fluid level ^a		<input type="checkbox"/>
Check the air filter indicator ^a		<input type="checkbox"/>
Check the V-belts	<input type="checkbox"/>	<input type="checkbox"/>
Drain the fuel system's water separator ^a		<input type="checkbox"/>
Underbody		
Drain water from air reservoirs ^a		<input type="checkbox"/>
Check transmission, rear axle and engine for leaks		<input type="checkbox"/>
Sides		
Visually check the wheel nuts.		<input type="checkbox"/>
Check the tyre pressure.		<input type="checkbox"/>
Check tyres and rims for wear and damage ^a	<input type="checkbox"/>	<input type="checkbox"/>
Remove stones from the tread and from between the double tyres	<input type="checkbox"/>	<input type="checkbox"/>
Check the closure of all side flaps	<input type="checkbox"/>	<input type="checkbox"/>
Check the radiator ^a		<input type="checkbox"/>

	Daily	Weekly
Front		
Check windscreen washer reservoir ^a		<input type="checkbox"/>
Check the condition of the windscreen wipers		<input type="checkbox"/>
Check the spare tyre pressure		<input type="checkbox"/>
Roof		
Check the roof unit dust filters ^a		<input type="checkbox"/>
Rear		
Check trailer connection ^a	<input type="checkbox"/>	
Interior		
Check seats for secure mounting and covers for damage and soiling		<input type="checkbox"/>
Check clutch fluid ^a		<input type="checkbox"/>
Check the front box dust filters ^a		<input type="checkbox"/>
Check seat belt security and reel mechanisms		<input type="checkbox"/>
Check if first aid kit, emergency hammers and fire extinguisher(s) are present	<input type="checkbox"/>	<input type="checkbox"/>
Check if doors, emergency exits and emergency valves open and close	<input type="checkbox"/>	<input type="checkbox"/>
Check whether the spare parts, jack, tools and hazard triangle are present.	<input type="checkbox"/>	<input type="checkbox"/>
Electrical system		
Check all exterior lights (parking lights, main and dipped beam, brake lights, fog lamps, reversing lights, clearance lights, registration plate lights, indicators and alarm lights)	<input type="checkbox"/>	<input type="checkbox"/>
Check the batteries' fluid level ^a		<input type="checkbox"/>
Check all interior lighting (main lights, dashboard, reading lamps and entry lighting)	<input type="checkbox"/>	<input type="checkbox"/>
Check dashboard instruments and signal lamps for operation and correct signal before and after starting	<input type="checkbox"/>	<input type="checkbox"/>
Check the operation of the windscreen wipers and the air horn	<input type="checkbox"/>	<input type="checkbox"/>

	Daily	Weekly
In freezing conditions		
Drain the water tank, boiler, coffee machine and toilet water supply	<input type="checkbox"/>	<input type="checkbox"/>
Windscreen washer antifreeze in reservoir	<input type="checkbox"/>	<input type="checkbox"/>
Antifreeze in chemical toilet	<input type="checkbox"/>	<input type="checkbox"/>

- a. These activities are discussed in more detail in the following pages.

DAILY CHECKS/MAINTENANCE

Carry out daily checks and maintenance as follows: [Maintenance checklist](#) (📖 84).

Open the engine compartment see: [Engine cover](#) (📖 19).

 **Preferably, turn off the engine before opening the engine compartment.**

Engine oil level electronically

The engine oil level will be checked electronically.

To perform a reliable electronically oil measurement, following requirements have to be achieved.

 **The level can only be measured and displayed when the engine is turned off. Therefore, the level is not monitored whilst driving!**

 **Make sure the vehicle is on a flat, horizontal surface.**

- 1. At the start of a new day**
 - Turn on the main switch and wait till the instrument panel has completed the start up cycle.
 - Turn the ignition switch to position I (see [Contact switch](#) (📖 24)) (engine not running) and wait **six seconds** for the electronic oil level inspection to be completed.
The engine oil level can be checked on the display (see [Display](#) (📖 54)).

- 2. After a journey**
 - Turn off the ignition switch and the main switch.
 - Wait for 15 minutes and proceed as at the beginning of a new day.



The oil level is sufficient to start the engine if the symbol opposite is not visible.



Low oil level



If the oil level is low, the yellow “low oil level” symbol will be displayed together with the yellow DMCI warning symbol. The amber central warning light will also be lit (see [Priority 2](#) (📖 51)).



Priority

In the display the oil level bar shows

Check the oil level using the dipstick, see: [Manually checking the oil level](#) (📖 88).

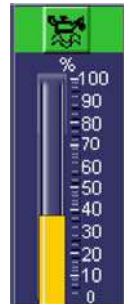

Oil level too high

 If the oil level is too high, the yellow “oil level too high” symbol will be displayed together with the yellow DMCI warning symbol. The amber central warning light will also be lit (see [Priority 2 \(📖 51\)](#)).



Priority

4 In the display the oil level bar shows

Check the oil level using the dipstick, see: [Manually checking the oil level \(📖 88\)](#).



Oil level too low

 If the oil level is too low, the red “oil level too low” symbol will be displayed together with the red DMCI warning symbol. The red central warning light will also be lit (see [Priority 1 \(📖 50\)](#)).



In the display the oil level bar shows

Check the oil level using the dipstick, see: [Manually checking the oil level \(📖 88\)](#).



Oil level measurement not possible

 If it is not possible to measure the oil level, the “No oil level measurement possible” symbol will be displayed (see [Priority 3 \(📖 53\)](#)).



In the display the oil level bar shows

Check the oil level using the dipstick, see: [Manually checking the oil level \(📖 88\)](#).

Manually checking the oil level

Use the dipstick to manually check the engine oil level.



Avoid skin contact with oil. Oil is bad for skin and health.

- Ensure the vehicle is standing on level ground.
- Turn off the engine and wait 5 minutes minimum.
- Remove the dipstick from its holder.

- Use a lint-free cloth to clean the dipstick.
- Insert the dipstick in its holder and wait a few seconds.
- Remove the dipstick again and read the engine oil level. It should always be between the two marks.
- Add oil as necessary via the filler opening.

Avoid overfilling.



An incorrect oil level may cause serious damage to the engine.

PR engines

- If the amber central warning light is displayed, 7.5 litres of oil must be added.
- If the red central warning light is displayed, 9 litres of oil must be added.

MX engines

- If the amber central warning light is displayed, 6 litres of oil must be added.
- If the red central warning light is displayed, 9 litres of oil must be added.



For the engine oil specification, see [Fluid and lubricant specifications \(144\)](#).

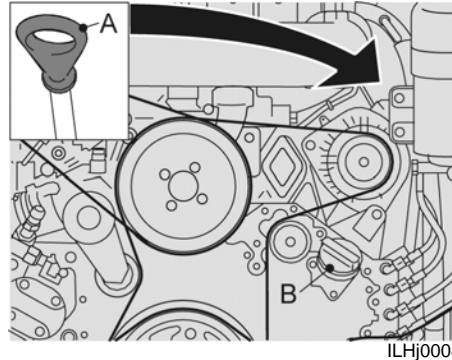

PR engine dipstick and filler cap

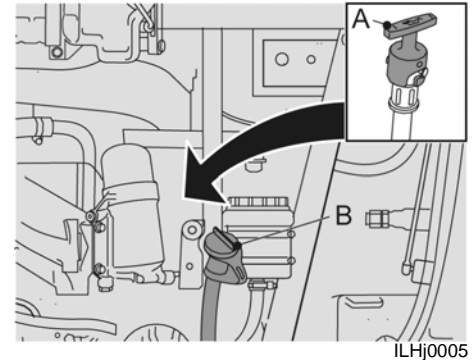

MX engine dipstick and filler cap

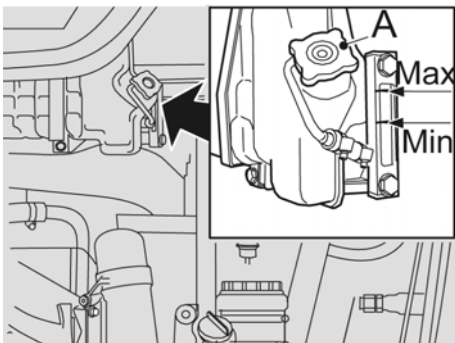

ILHJ0001

4

Coolant level

Check coolant level when the engine is cold.

If coolant level is below the minimum, checks for leaks must be carried out.



When the coolant is warm, the cooling system will be pressurized. In that case cover the filler cap with a thick cloth and remove it slowly and gradually, allowing pressure to escape. Then remove it completely.



Coolant is a harmful liquid. Therefore, avoid skin contact to prevent poisoning.



To avoid damage to the engine block when adding cold coolant to a warm engine, add it slowly while the engine is running.

Remove filler cap A from the reservoir.

Fill the reservoir to the maximum.

See [Technical information \(📖 137\)](#) for the coolant specifications.

Bring the engine to the operating temperature.

Switch off the engine and check the coolant level.

WEEKLY CHECKS AND MAINTENANCE

Carry out the following weekly checks and maintenance: [Maintenance checklist](#) (📖 84).

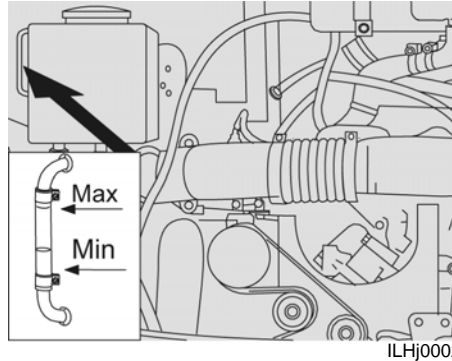

Hydraulic fluid

Check that the fluid level is between the two marks.

If necessary, top it up via the filler opening. See [Technical information](#) (📖 137) for the hydraulic fluid specifications.

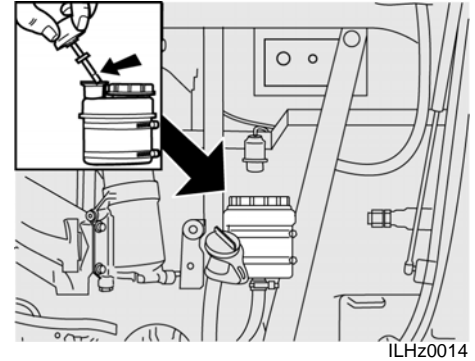

Power steering fluid

When the engine is turned off, check whether the fluid is approximately 2 cm above the top mark on the dipstick.

If necessary, top up the fluid.

Start the engine (the engine cannot be started when the bonnet is open).

When the engine is idling, the fluid must reach the top mark on the dipstick.

See [Technical information](#) (📖 137) for the power steering fluid specifications.

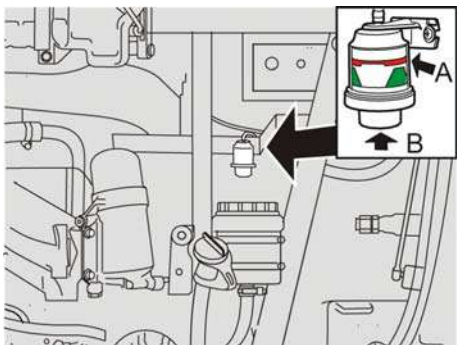

ILHJ0004

4

Air filter

There is an indicator fitted, which indicates whether the filter needs to be replaced.

If the air filter is normal/clean, the indicator is in the green area.

If the indicator is in the red area (A), the air filter is seriously fouled and must be replaced.

Clean the filter housing before replacing the dust filter. After replacing the filter, reset the indicator by pressing button (B).



Do not use this space for storage.

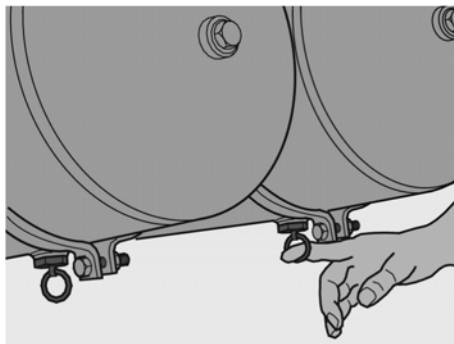

ILHi0006

Brake system air dryer

Drain the water from the air reservoirs by pulling on the ring.

The air tanks are best reached via the spoiler flap.

If more water is regularly drained off than has been usual, the air dryer filter element must be replaced (consult a VDL Bus & Coach workshop).

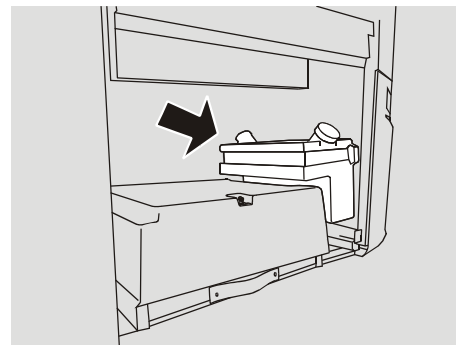

ILHz0005

Windscreen washer fluid

Check the fluid level and, if necessary, top it up.

Add cleaning fluid in the summer.

Add special windscreen washer antifreeze in the winter.

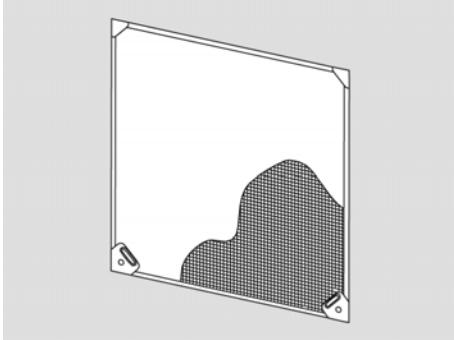

ILHJ0013

Radiator

Check the gauze which is fitted in front of the cooling unit as extra protection against contamination. If necessary, clean the gauze.



Make sure the radiator's lamellae are not damaged.

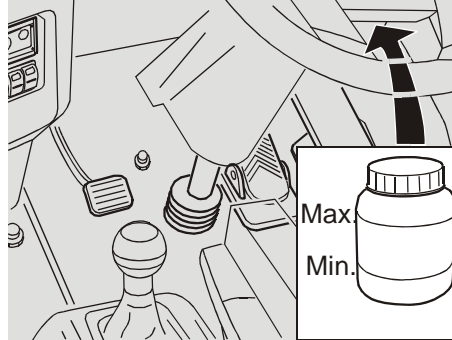

ILHz0007

Clutch fluid

Check the level of the clutch fluid. The fluid level must be between the marks. If necessary, top it up. See [Technical information \(📖 137\)](#) for the clutch fluid specifications.

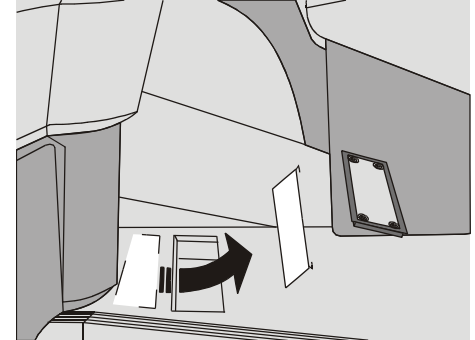

ILHg0001

Front box dust filter

The dust filter in the front box is accessible via the hatch in the floor near the front entryway. Unlock the hatch by loosening the bolts (5mm Allen key). Remove the hatch. Remove the filter. Clean or if necessary replace the filter. Clean the filter housing before replacing the dust filter.

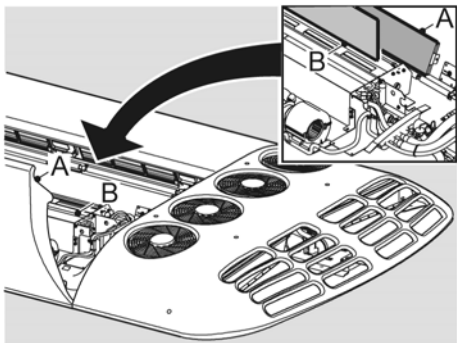

ILHg0002

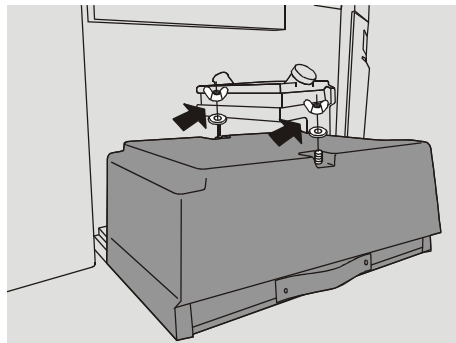

ILHh0039

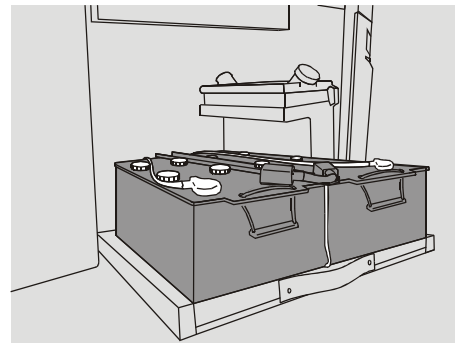

ILHh0040

4

Roof unit dust filters

The dust filters are located in the roof units.



Except in case of emergency, it is not permitted to climb onto the roof by means of the roof hatches.

Clean the area around the roof units.

Open the roof units (cross-headed screwdriver).

Remove leaves, twigs etc. from filter A and clean the filter.

Clean the filter housing.

Check and if necessary replace filter B.

Close and lock the roof units.

Batteries

The batteries are located front right, behind a closeable flap.

The battery cover can be removed by undoing the two wing nuts.

Check the electrolyte level. It must be around 5 mm above the plates. Refill as necessary with distilled water.



Battery acid is an aggressive fluid. If it comes into contact with your clothes, eyes or skin, rinse with plenty of water.

Check that the battery contacts and clamps are clean and well-greased. If necessary, lubricate them with acid-free Vaseline.

Don't forget to replace the battery carriage securing pins after these checks.

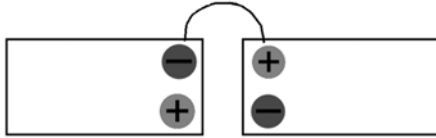
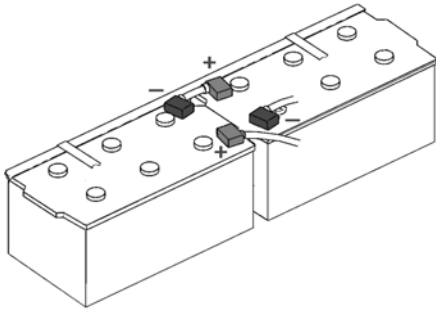

ILAh0770

Disconnecting and connecting the battery cables



There is a risk of a short circuit if the battery's positive cable comes into contact with parts of the vehicle. An explosive gas (oxyhydrogen) may be released if there is a short circuit.



Do not place metal objects or tools on the batteries.

When removing the battery terminal clamps, always remove the black (-) cable before the red (+) cable.

When connecting the battery terminal clamps, always connect the red (+) cable before the black (-) cable.



The DTCO tachograph saves an error code if the battery terminal clamps are disconnected. In some countries, the error code is interpreted as a breach of the law. To prevent the unit from saving an error code when disconnecting the battery cables, place a DTCO workshop card in the unit whilst the battery is disconnected.

If an error code is saved, contact a recognized DTCO service dealer to calibrate the DTCO and to delete the code.

Disconnecting the battery terminal clamps

1. Turn off all the electrical consumers.
2. Turn off the contact switch and the main switch.
If applicable, remove the contact switch key.
3. Wait 5 minutes after turning off the contact switch and the main switch.
4. Open the front left-hand service hatch.
5. Open the battery box (see [Batteries \(94\)](#)).
6. Disconnect the negative cable and then the positive cable from both batteries.

Connecting the battery terminal clamps

1. Check whether the contact switch and the main switch are turned off.
If applicable, remove the contact switch key.
2. Check whether all the electrical consumers are turned off.
3. Make sure the battery terminals and the battery terminal clamps are clean and well lubricated with Vaseline. If necessary, lubricate them with acid-free Vaseline.
4. Connect the positive cable first and then the negative cable of both batteries.
5. Close the battery box (see [Batteries \(94\)](#)).
6. Close the service hatch.

OVERVIEW OF THE MONTHLY INSPECTIONS WHEN USING BIODIESEL

Diesel is a poisonous substance. Physical contact may lead to serious health problems.



Avoid bodily contact.



In the event of skin contact: remove the substance with paper or a cloth and wash with soap. Contact a doctor in the event of persistent irritation.



In the event of contact with the eyes: wash for at least 15 minutes with plenty of water and visit a doctor.



If swallowed: Do NOT induce vomiting. Rinse your mouth, drink a lot of water and contact a doctor.



In the event of inhalation: get some fresh air and take a rest. Contact a doctor.



Fuel is highly inflammable and may cause a fire or an explosion, which can result in a serious injury.



Collect any fuel which escapes.



Avoid sparks and a naked flame near the fuel.



Dirt in the fuel system may cause serious damage to the fuel system.



Work in a clean environment when working on the fuel system.



Clean the area around the fuel system's components before starting work on the fuel system.

- The contents of the fuel tank for water, contamination and bacteria growth. If necessary, clean it.
- The seal of the fuel tank's filler cap for leaks. If necessary, replace it.

Visually check the components listed below once a month for the following:

- (Flexible) fuel hoses between the lines and the engine for leaks. If necessary, replace them.

WATER SYSTEM



The owner of the vehicle is at all times responsible for the quality of the water used in the vehicle.

In order to reduce the development of legionella bacteria to a minimum, the following issues need to be considered:

Main water tank

- Rinse with disinfectant once a month. Fill the tank to the rim and then add disinfectant in accordance with the product instructions. Next, drain the water via the vehicle's line system and thoroughly rinse the system before using it again.

Extra (drinking-) water tank

- Inspect once a fortnight or inspect with every filling if the tank is not filled through the normal couplings, but through the inspection panel.
- In case of scale formation in the tank, it should be cleaned according to the aforementioned method.

Water conduits

As the hosepipes are rinsed out while cleaning the tank, a visual inspection of the hosepipes while filling the water tank should be sufficient.

Connected devices

- The temperature of the water heater should be set to the maximum temperature (approx. 85° C). Along with cleaning the tanks and the pipes, this will minimize the risk of infection.



Connecting a washing installation to the main water tank increases the risk of legionella infection.

BEFORE THE WINTER

Checking the antifreeze concentration

Check the coolant's antifreeze concentration

If anti-freeze has not been added already, fill the cooling system with anti-freeze.



To avoid damage to the engine block when adding cold coolant to a warm engine, add it slowly while the engine is running.

Only use coolant or, if appropriate, anti-freeze which satisfies VDL Bus & Coach specifications (see [Technical information \(📖 137\)](#) and [Fluid and lubricant specifications \(📖 144\)](#)).

No variation is permissible because of the aluminium radiator fitted.

Follow the manufacturer's instructions for the correct composition of coolant when adding anti-freeze.

Windscreen and headlight washer reservoir

Add antifreeze to the windscreen washer fluid.

Air conditioning

The air conditioning system has a so called "season-off control", which automatically takes care that the compressors run regularly for several minutes to allow oil to be pumped around the system, preventing the seals from drying out.

Fuel

During the winter months the fuel suppliers often use additives to prevent paraffin deposits, which cause blockages.

In extremely low temperatures a maximum of 20% petroleum may be added.

If this is not legally permitted, then a maximum of 20% unleaded petrol can be added.

Fuel additives to prevent paraffin deposits have only a preventative effect. They are not suitable for dissolving the paraffin.



Ensure that a spare fuel filter is available so that the filter can be replaced in the event of a blockage (also if it was caused by paraffin deposits) (see [Replacing fuel filters](#) (113)).

Batteries

The demands that are placed on the batteries in the winter are much higher than in the summer, because the lights, windscreen wipers, etc. are used more often. Also, the battery capacity is lower at lower temperatures.

A poorly charged battery can become frozen if it becomes very cold.

Regularly check the charging state of the batteries and, if necessary, lubricate the battery poles with acid-free Vaseline.

Locks

Use special lock oil for the locks (Teflon spray).

Avoid the use of de-icer sprays, because they have a negative effect on the locks.

Door and hatch rubbers

To avoid the doors and hatches from freezing closed, the rubbers must be regularly treated with talcum powder during the winter.

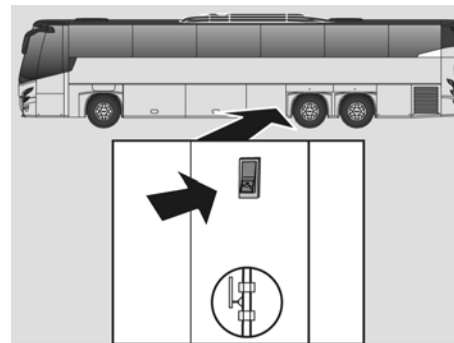

ILHk0011

Kitchen and toilet water system

Operating this switch disables the water reservoir empty alarm.

The water can subsequently be pumped out of the tank by operating the tap in the vehicle.



Reset the switch after emptying the tank, so that the warning light works again. This will prevent the reservoir from running empty.



Make sure that all reservoirs and pipes are drained to prevent freezing.

AFTER THE WINTER

Cooling system

The anti-freeze mixture may be left in the system during the summer.

Windscreen and headlight washer reservoir

It is recommended to add cleaning fluid to the water.

EXTERIOR

Washing

Wash the vehicle as soon as it is dirty in winter, as salt and dampness easily cause corrosion.

Remove bird droppings as soon as possible from the paintwork! Bird droppings contain substances which attack and discolour paintwork. The discolouration cannot be polished away.



Always wash the vehicle in a suitable place.

You can wash the vehicle as follows:

Hand washing

- Carefully hose off the soiling from the underside of the vehicle (wheel arches, around mud flaps etc.).
- Hose down the whole vehicle to loosen the dirt. Avoid spraying directly into locks.
- Wash the vehicle using a sponge, with or without a cleaning agent. Use lukewarm water for preference, but avoid hot water.
- Dry the vehicle with a clean, soft chamois.

Cleaning with a high pressure jet washer

Take care that the spray head of the jet washer does not come closer than 30 cm from the coachwork. Also, avoid spraying into or near the locks of the various hatches and doors and the engine compartment.

Cleaning in a car wash

The vehicle can be washed quickly and simply in a vehicle washing machine.

Bear in mind, however, that the vehicle washing machine cannot clean the vehicle as carefully and effectively as you can with a sponge and water.

The car-wash brushes cannot reach into all areas.

Before entering the vehicle washing machine, ensure that any extra equipment is properly secured, or it may be pulled loose by the brushes.

Only wash the vehicle in a vehicle washing machine with clean brushes.



It is not recommended to use a vehicle washing machine for the first few months as the paint layers may not have sufficiently hardened.



Depending on the type of car wash, it may be necessary to fold in or remove the mirrors (see **Removing mirrors (📖 69)**).

Cleaning agents

Car shampoo, or 5 - 10 cl ordinary washing-up liquid to 10 litres of water.

Spotting on aluminium may be removed with car polish.

Never use polishing paste or steel wool.

4 Waxing and polishing

You should wax and polish the vehicle if you find that the paint has lost its gloss and normal washing doesn't restore the original gloss.

Normally the vehicle exterior will need polishing only after a year.

You may apply wax before then.

Wash and dry the vehicle well before polishing or waxing.

Remove any asphalt and tar spots with white spirit.

Stubborn marks may be removed with a fine car paint polish.

There are many brands of polymer wash materials on the market. These are easy to work with and give a hard and very glossy

surface which protects the paint against oxidation, dirt and dulling.

TOUCHING UP PAINTWORK

General information

Paint damage on metal parts must be dealt with without delay to prevent rust formation.

It is advisable to check the paintwork regularly, perhaps after each wash, to touch up any possible damage.

Small spots and scratches can be touched up with a paintbrush.

Larger areas of paint damage require special equipment and expertise. It may be advisable to have more major damage repaired by a specialist workshop.

Minor scratches and stone damage

If the chipping caused by stones has not penetrated to the metal, and undamaged paint is still present, you may paint directly over the spot, after polishing to remove dirt.

If the chipping has penetrated to the metal you must proceed as follows.

- Sand the damage area down to the metal and remove sharp paint edges with a sharp knife.

- Use a rust removal agent on the metal, wait for several minutes and then wash well with water. Then rub dry. (this treatment is not needed on plastic substrates).
- Stir the primer well and apply it.
- When the primer has dried apply the top coat with a brush.

INTERIOR MAINTENANCE

General information

Remove soiling as soon as possible before it has dried in.

Soiling should be dissolved away, rather than rubbed, scraped or removed with a hard brush.

Always work from the edge of the soiling towards the middle.

Cleaning upholstery

The fabric upholstery of the seats can generally be cleaned with soap and water or a detergent solution.

With difficult stains like oil, ice-cream and shoe-polish, a special cleaning agent may be used. Follow the cleaning agent manufacturer's instructions.

Use solvent cleaners sparingly. Excessive use of solvents may damage the foam plastic filling of the seats.

Cleaning curtains and seat covers

Curtains and seat covers can normally be washed in cold water.

If they are soiled they can be washed at 30 °C.

Bleach should not be used.

The use of washing powders may cause discolouration.

To keep the colours uniform, the curtains or covers should all be washed at the same time.

The covers should not be ironed.

Cleaning plastic

Plastic parts should be cleaned with a lukewarm solution of synthetic cleaning agent.



Avoid the use of trichloroethylene, petrol and similar materials on plastics.

Cleaning carpets

Soak up as much as possible with clean cloths.

Vacuum around the affected area to avoid spread.

Dampen the affected areas with textile cleaning agent on a clean cloth.

Soak up the cleaning agent with a dry cotton wad. Repeat the process until the soiling is gone.

5 REPAIRS WHILST ON THE ROAD

GENERAL INFORMATION.....	105
ON-BOARD TOOL KIT	106
ENGINE COMPARTMENT	107
EMERGENCY OPERATION OF THE CLIMATE SYSTEM	114
EBS SYSTEM	116
PNEUMATIC SUSPENSION LEAK.....	116
WHEELS AND TYRES	116
REPLACING LIGHT BULBS	120
REPLACING FUSES	121
JUMP STARTING.	122
TOWING	123
ITS-VDL.....	126

GENERAL INFORMATION

Although the vehicle may be well maintained, it is still possible that a problem arises, such as a flat tyre or a faulty headlight, that you will have to repair yourself in order to continue your journey.

Safety



Before attempting to carry out repairs, you must first ensure your own safety and that of the passengers. Therefore, stop and park the vehicle in a safe place and, if necessary, allow the passengers to wait in a safe location close to the vehicle.

Safety vest

When carrying out emergency repairs, always wear a safety vest (it is a legal requirement in some countries) and, if necessary, also use other means of marking.

Cleanliness

It is extremely important that you make sure you keep the work area clean when repairing a fault, to avoid the repair work from resulting in another fault due to unnecessary contamination.

A clean work area also improves safety. Once the fault has been rectified, make sure to return the area to its original state.

ON-BOARD TOOL KIT

The vehicle is equipped with an on-board tool kit including:

	Number
Tool kit	1
4mm drift	1
Tommy bar/wheel nut spanner	1
Ring spanner 12 x 13	1
Ring spanner 14 x 15	1
Ring spanner 16 x 17	1
Ring/open-end spanner 18	1
Allen key set	1
cross-headed screwdriver	1
150 mm screwdriver	1
75 mm screwdriver	1
Bench hammer, 400 g	1
Adjustable spanner	1
Combination pliers	1
Water pump pliers	1
VDL Bus & Coach bag	1
Wheel key	2
Jack and foot	1
Jack rod	1
Tyre inflation hose	1

Inspection lamp with plug	1
Towing eye assembly (mounted behind the spoiler flap)	1
Square spanner	1
Special spanner for hatches	2
Spare wheel puller	1
Lamp kit with fuses	1

The on-board tool kit is located in the extra storage compartment to the right behind the rear axle.

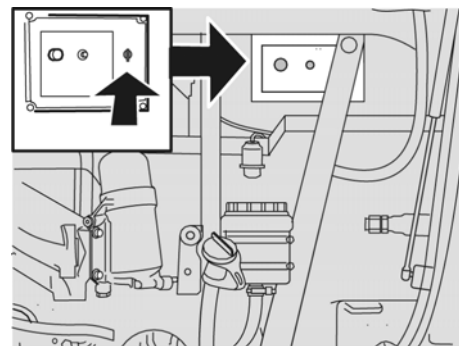

ILHh0047

Inspection lamp connection

The 24 volt inspection lamp can be connected to 3 sockets in the vehicle.

Fuse box in engine compartment and main fuse box in luggage compartment:

The inspection lamp, without its plug, may be connected as shown in the illustration above.

24 Volt connection

To connect the inspection lamp to the 24 Volt connection, the adaptor plug must be connected to the inspection lamp's plug (see [Plug \(📖 107\)](#)).

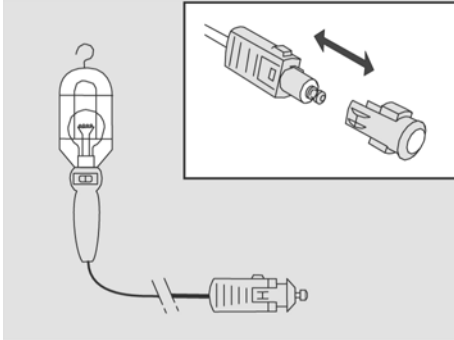

ILHh0050

Plug

Fit the adaptor plug to the inspection lamp's plug for use in the 24 Volt connection as illustrated.

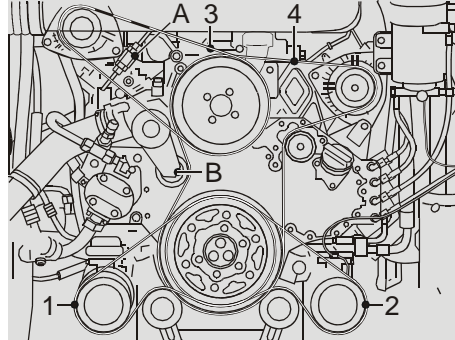

ILHj0007

ENGINE COMPARTMENT

Changing the V-belts on a PR engine

- 1, 2 Replacing the air conditioning belts for a PR engine (📖 108)
- 3 Removing and installing the generator V-belt for a PR engine (📖 108)
- 4 Replacing a poly V-belt for a PR engine (📖 109)



If two V-belts are used for a drive, both belts must be replaced.



Always fit the same type of V-belt.

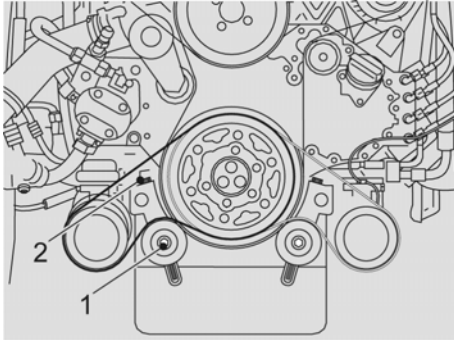

ILHJ0006

- Use bolt 2 to adjust the air conditioning belt tension. If the V-belt is correctly tensioned, it can be pushed down 10 mm when slightly pressed between the air conditioning pulley and the crankshaft pulley (A).
- Tighten bolt 1.



Check the new V-belts after the first 50 km and have the V-belt tension checked as soon as possible by a VDL Bus & Coach service dealer.

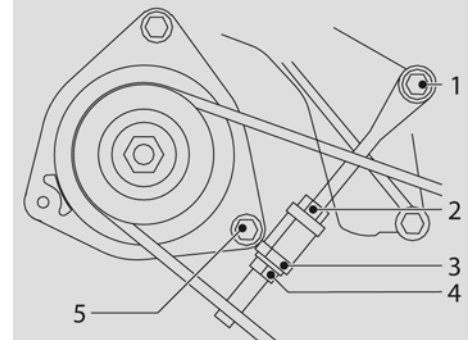

ILHJ0015

Replacing the air conditioning belts for a PR engine

5



Always fit the same type of V-belt.

- Unscrew bolt 1 from the pulley.
- Unscrew bolt 2 until the air conditioning belt can be removed.
- Inspect the pulleys for damage, rust and grease deposits.
- Fit a new air conditioning belt.

Removing and installing the generator V-belt for a PR engine

- Disconnect the earth cable from the battery.
- Unscrew the threaded spindle's lock nut (2).
- Unscrew the threaded spindle's attachment bolt (1).
- Unscrew the generator's bottom attachment bolt (5).
- Unscrew the threaded bush's (4) lock nut (3).
- Use the threaded bush (4) to move the generator until the V-belt(s) can be removed.
- Check the pulleys for damage, rust and grease deposits.

- Fit the new V-belt(s).
- Adjust the V-belt tension (see “Adjusting the V-belt tension”).
- Reconnect the battery’s earth cable.

⚠ Check the setting of the new V-belts after the first 50 km and have the V-belt tension checked as soon as possible by a VDL Bus & Coach workshop.

Adjusting the generator V-belt tension for a PR engine

- Unscrew the threaded spindle’s lock nut (2).
- Unscrew the threaded spindle’s attachment bolt (1).
- Unscrew the generator’s bottom attachment bolt (5).
- Unscrew the threaded bush’s (4) lock nut (3).
- Move the generator by rotating the threaded bush (4) until the correct V-belt tension is obtained.

If a V-belt is correctly tensioned, it can be pushed down 10 mm by slightly pressing it between the generator and the water pump pulley (A).

- Tighten the lock nuts (2 and 3) and the attachment bolts (1 and 5).



Check the new V-belts after the first 50 km and have the V-belt tension checked as soon as possible by a VDL Bus & Coach service dealer.

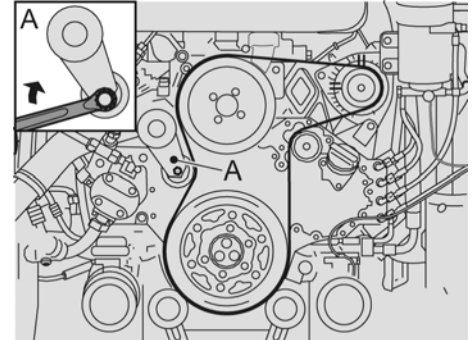

ILHJ0014

Replacing a poly V-belt for a PR engine



Always fit the same type of poly V-belt.

- Disconnect the earth cable from the battery.
- Remove the V belt(s) from the extra generator and the air conditioning compressor (see [Removing and installing the generator V-belt for a PR engine](#) (📖 108)).

Repairs whilst on the road

- Place a 17 mm ring spanner on the automatic belt tensioner's hexagon (A).



It is possible to temporarily block the tensioner with a 4 to 5 mm thick pin (drill bit) (see A in the diagram). This will make it easier to assemble and disassemble the poly V-belt.

- Slacken the poly V-belt so that it can be removed from the belt discs.
- If the tensioner has not been temporarily blocked, allow the automatic belt tensioner to slowly spring back to the stop.
- Remove the poly V-belt.
- Check the pulleys for damage, rust and grease deposits.
- Fit a new poly V-belt.
- Place the new poly V-belt over as many pulleys as possible.
- Use a 17 mm ring spanner to tighten the automatic belt tensioner (if it has not been temporarily blocked) and place the poly V-belt over the remaining pulleys. Allow the automatic belt tensioner to slowly spring back against the new poly V-belt.

- If used, remove the blocking pin. The blocking pin can be removed by moving the pulley against the spring force.
- Check that the poly V-belt lays in all the pulley grooves.
- Fit the V-belt(s) that was/were removed from the extra generator and the air conditioning compressor (see [Removing and installing the generator V-belt for a PR engine](#) (108)).
- Reconnect the battery's earth cable.

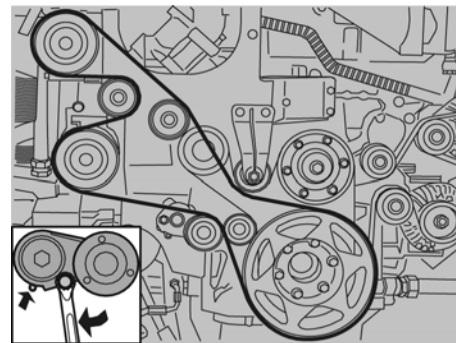

ILHJ0016

Changing the V-belts on an MX engine

Replacing the air conditioning belt for an MX engine



Always fit the same type of V-belt.

- Slacken the multi-V belt by turning the spanner against the belt tensioner spring pressure.
- Place a drift at position C so that the spring tensioner is locked and remove the V-belt from the pulleys.
- Inspect the pulleys for damage, rust and grease deposits.
- Fit a new V-belt.

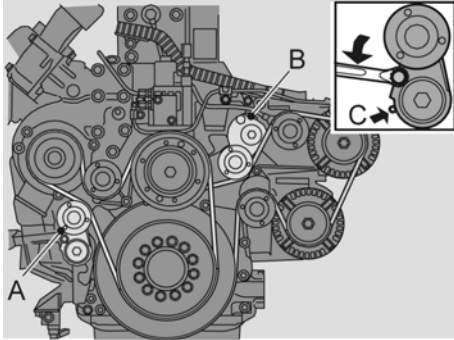

ILHJ0017

Replacing the poly V-belt for an MX engine

 **Always fit the same type of poly V-belt.**

- Disconnect the earth cable from the battery.
- Remove the air conditioning belt, see [Replacing the air conditioning belt for an MX engine](#) (📖 110)
- Fit a suitable spanner to the automatic belt tensioning mechanism A and/or B.
- Slacken the multi-V belt by turning the spanner against the belt tensioner spring pressure.

- Place a drift at position C so that the spring tensioner is locked and remove the V-belt from the pulleys.
 - Inspect the pulleys for damage, rust and grease deposits.
 - Fit a new V-belt.
 - Remove the drift and cautiously allow the automatic belt tensioner to take up tension against the new V-belt
 - Check that the poly V-belt lays in all the pulley grooves.
 - Install the air conditioning belt.
- Reconnect the battery's earth cable.

Replacing the fuel preliminary filter/ water separator

Diesel is a poisonous substance. Physical contact may lead to serious health problems.



Avoid bodily contact.



In the event of skin contact: remove the substance with paper or a cloth and wash with soap. Contact a doctor in the event of persistent irritation.



In the event of contact with the eyes: wash for at least 15 minutes with plenty of water and visit a doctor.



If swallowed: Do NOT induce vomiting. Rinse your mouth, drink a lot of water and contact a doctor.





In the event of inhalation: get some fresh air and take a rest. Contact a doctor.

 Fuel is highly inflammable and may cause a fire or an explosion, which can result in a serious injury.

 Collect any fuel which escapes.

 Avoid sparks and a naked flame near the fuel.

 Dirt in the fuel system may cause serious damage to the fuel system.

 Work in a clean environment when working on the fuel system.

 Clean the area around the fuel system's components before starting work on the fuel system.

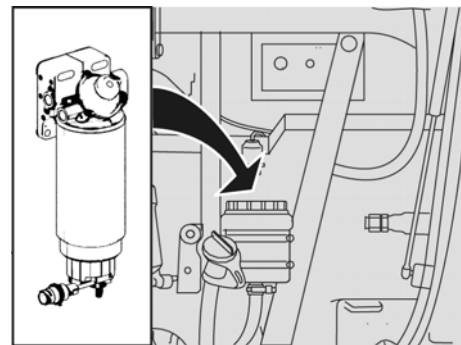
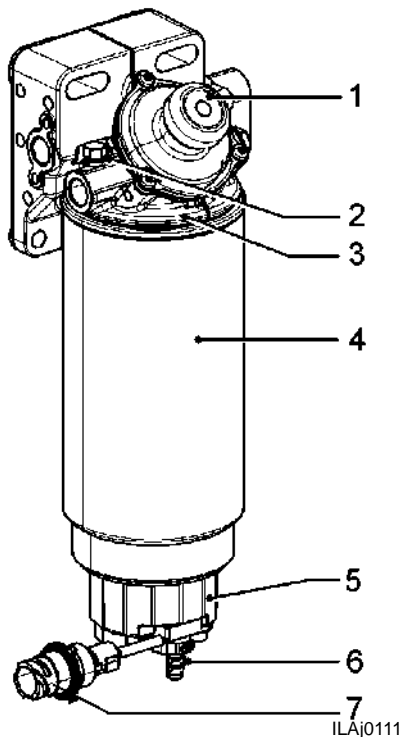

ILHJ0018

Removing and installing the fuel preliminary filter

- Open the bleed plug (2).
- Drain the fuel out of the filter element by screwing the drain plug (6) open.
- Disconnect the connector (7) from the water sensor and the heating element.
- Remove the filter element (4) together with the base cover (5).
- Remove the base cover (5) from the filter element (4).
- Clean the seal of the base cover's (5) O-ring.
- Apply a thin layer of engine oil to the base cover's O-ring.
- Fit the base cover in the new filter.

- Apply a thin layer of engine oil to the new filter's sealing ring.
- Fit the new filter element (4), together with the base cover (5), to the filter housing (3).
- Tighten the filter (3) by hand.
- Connect the connector (7) for the water sensor and the heating element.
- Bleed the fuel system (see [Bleeding the fuel system with the fuel preliminary filter/water separator](#) (📖 113)).

Bleeding the fuel system with the fuel preliminary filter/water separator

- Open the bleed screw (2).
- Pump using the hand pump (1) until fuel without air bubbles flows out of the bleed screw (2).
- Tighten the bleed screw (2).
- Start the engine and check the fuel system for leaks.
- If necessary, retighten the filter element (4) by hand.

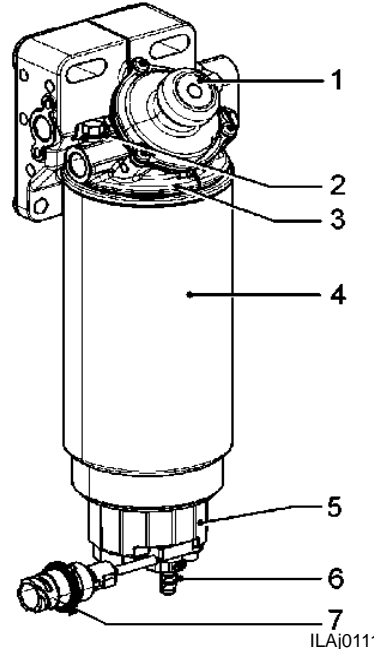

Draining the water from the preliminary fuel filter/water separator

- Check the base cover (5) for the presence of water.
- If necessary, open the drain plug (6) and use the hand pump (1) to pump out the water.

- Close the drain plug (6).
- If necessary, bleed the fuel system (see [Bleeding the fuel system with the fuel preliminary filter/water separator](#) (📖 113)).

Replacing fuel filters



Diesel is inflammable and may not be exposed to a naked flame or other heat sources, such as a hot engine. Collect any drained fuel in a suitable container.

Cleaning a coarse fuel filter

It may be necessary to clean the coarse filter as a result of, for example, paraffin deposits.

- Unscrew the lower part of the filter housing (1) and clean the filter.
- Check the sealing rubber and replace, if necessary.
- Lubricate the sealing rubber sparingly with engine oil.
- Reassemble the filter and filter housing in the reverse order (torque 10 Nm).
- Check the fuel system for leaks with the engine running.

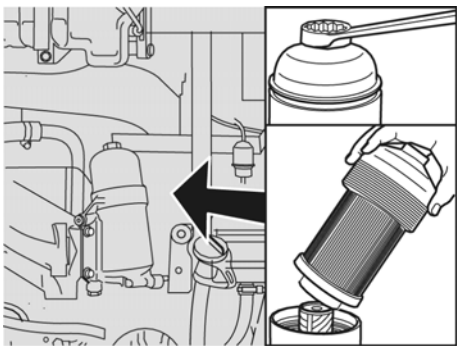

ILHJ0003

Replace the fuel fine filter

The fuel fine filter is located on the right-hand side of the engine next to the power steering reservoir.

Replace the filter according to the method given below:

- Remove the filter by rotating the filter housing cap to the left, whereupon the filter element can be replaced.
- Check the sealing rubber and replace if necessary.
- Lubricate the sealing rubber sparingly with engine oil.
- Place a new filter element in the cap and replace the cap, together with the filter element, in the filter housing.

- Screw the new filter home (torque 25 Nm).
- Bleed the fuel system.
- Check the fuel system for leaks with the engine running.

EMERGENCY OPERATION OF THE CLIMATE SYSTEM

If the display fails to function, the power supply is possibly disconnected.

- Check fuses 68, 70 and 94 (see fuse list).
- Check if the V-belt tension of the airco compressors is O.K., see: [Replacing the poly V-belt for an MX engine](#) (📖 111).
- Check the dust filters in the roof units, see: [Roof unit dust filters](#) (📖 94).
- Check the dust filter in the frontbox, see: [Front box dust filter](#) (📖 93).

The climate system is provided with on board diagnostics, which checks the operation of a number of components. If a fault is detected this is indicated by a warning triangle on the display.

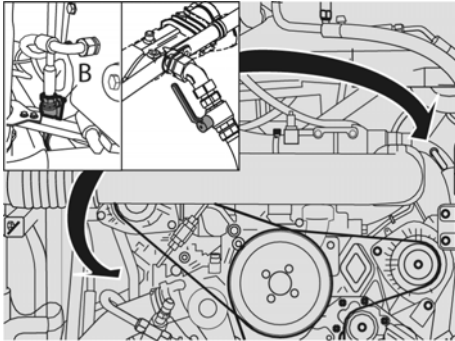

ILHJ0010

PR engine heating taps

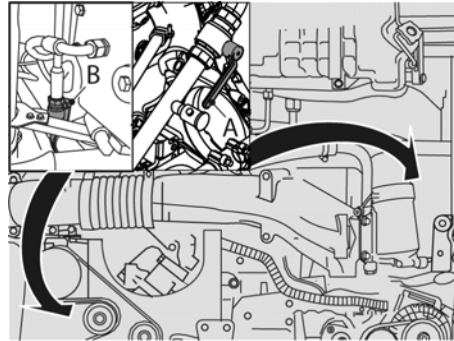

ILHJ0009

MX engine heating taps

Heating system leaks

If leaks occur in the heating system, it is possible to isolate the system from the engine cooling system.

Valves (A + B) should be closed in the case of leaks in the climate system.



If the vehicle cannot be adequately heated, the water valves may be partly or completely closed: check the water taps and ensure that they are completely open.

EBS SYSTEM

Illumination of the red warning light at speeds above about 7 km/h indicates a fault in the EBS system.

Check the EBS system fuses.

If the fault is not rectified by replacing the fuses, the journey may not be continued, because the EBS system is not working.

 **Have the EBS system repaired by an authorised workshop.**



PNEUMATIC SUSPENSION LEAK

If a spring bellows develops a fault the ECAS symbol will light up on the display. Switch the axle in question to "kneel" and then switch off the ECAS system. The switch is in the fuse box in the right luggage compartment.

 **The journey may continue, at a reduced speed.**

The fault must be repaired as soon as possible.

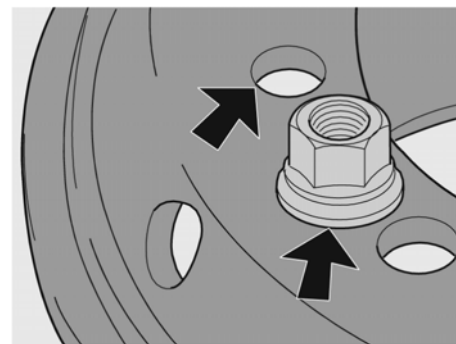

WHEELS AND TYRES

General information

VDL Bus & Coach fit their coaches with the so-called wheel hub centering system.

Characteristics of wheel hub centering are:

- Wheels with cylindrical bolt holes.
- Wheel nuts with a loose, non-removable, flat thrust washer.

 **Use only the appropriate wheel hub centering wheels and wheel nuts.**

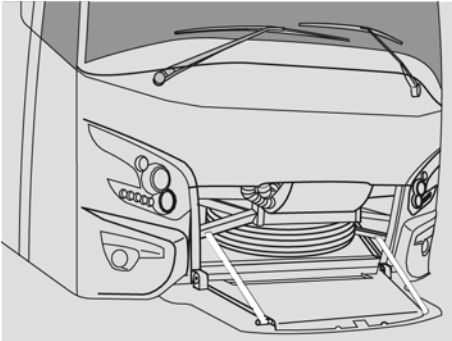

ILHa0008

Spare wheel

The spare wheel is located behind the spoiler flap.

The spoiler flap is opened by pulling on the handle next to the steering column, see: [Spare wheel compartment handle \(41\)](#).



First check whether the spare wheel is in a usable condition and, if necessary, inflate it to the correct pressure (see [Tyre pressure \(139\)](#)).

Remove the spare wheel by taking off the clamp and pulling a draw band through the wheel so that it can be pulled out.

Changing wheels

- Park the vehicle in a safe location on an asphalted, horizontal road surface.
- Block the wheels so that the vehicle cannot roll away.
- If necessary, turn on the hazard warning lights and place a warning triangle a distance of at least 30 m behind the vehicle.
- Remove the wheel cover by pulling it firmly.
- Clean the wheel nuts and apply a drop of oil to the screw thread.
- Unscrew the wheel nuts half a turn.
- Place the jack near the wheel to be replaced (see [Jack points \(118\)](#)) and jack up the vehicle until the wheel comes off the ground.



Read the documentation supplied with the jack before using it.

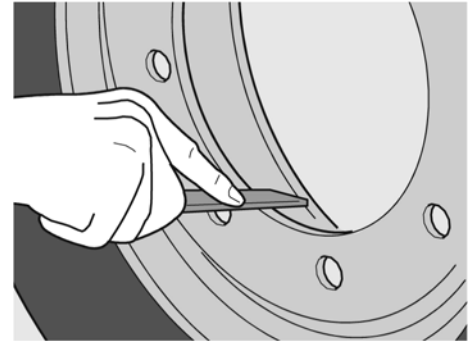

ILHz0003

- Remove the wheel nuts and remove the wheel.
- Before fitting the wheel, carefully clean the wheel hub's fitting edge and the inside edge of the spare wheel and remove any burrs or paint residue. Lightly smear the fitting face with grease.

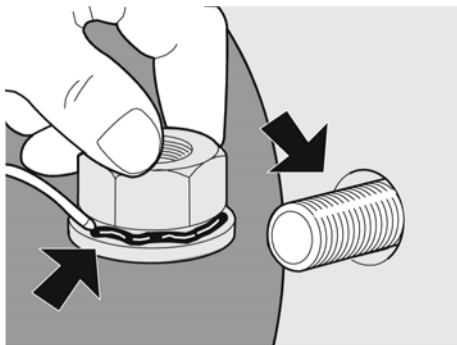

ILHz0004

- Clean the wheel studs and apply oil to the threads.
- Apply a drop of oil between the pressure ring and the wheel nut.
- Fit the wheel and tighten the nuts.
- Remove the jack and tighten the nuts sequentially and diagonally to the prescribed torque ($600\text{Nm} \pm 3\%$).
- Install the wheel cover.



Retighten after 100 km.

Stow the spare wheel and the tools.
Do not forget the warning triangle.

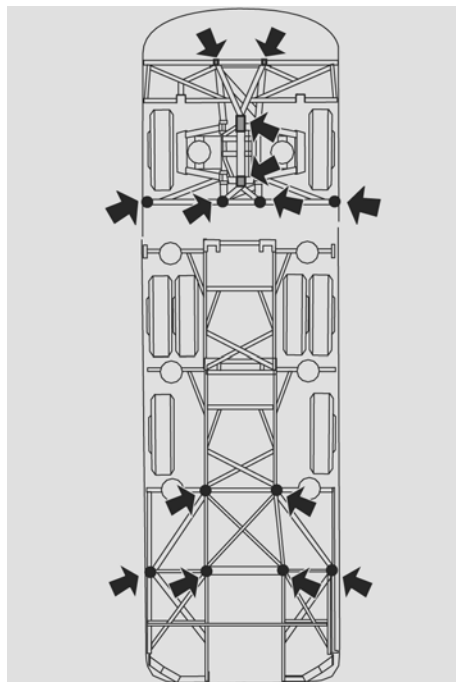

ILHf0000

Jack points

The jacking points detailed above have been provided to jack the vehicle up.

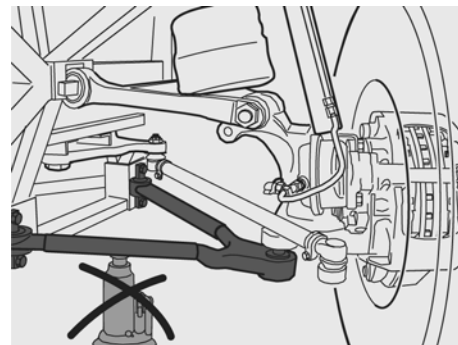

ILHf0001



Never put a jack under the suspension triangle of the front axle or under the differential housing, or under the body of the rear axle.



Always use supports when working under a jacked up vehicle.



Read the documentation supplied with the jack before using it.

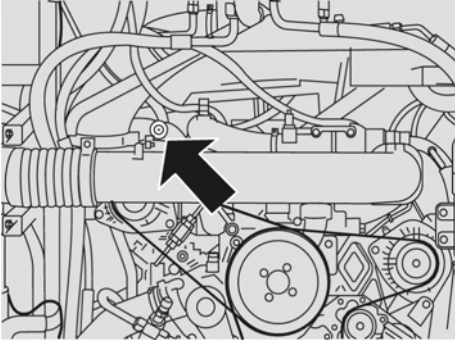

ILHi0011

PR engine emergency filler connection

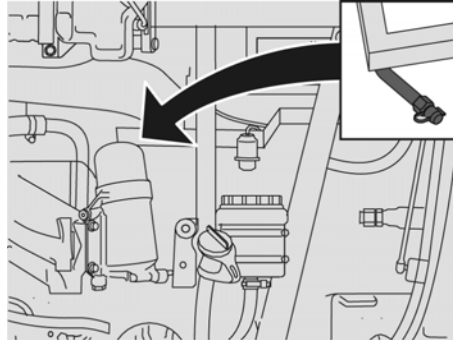

ILHi0013

MX engine emergency filler connection

Inflating a tyre

Remove the cap from the emergency inflation connection.

Connect the tyre inflating hose.

Pump up the tyres. The engine must be running but the stored pressure must not be at maximum, otherwise the compressor will not deliver air.



The pressure can be lowered by operating the brake pedal.

For correct tyre pressures see: [Tyre pressure \(📖 139\)](#).

REPLACING LIGHT BULBS

General information

Never touch the glass of a light bulb with bare fingers. Traces of grease, oil or other irregularities will adhere to the glass and reduce the lifespan of the lamp.

The reflector will be affected by vaporization of the irregularities.



Use the light bulb's packaging as protection between your fingers and the glass.



Check the headlight setting when the headlight's bulb is replaced.

5

For a complete list of the lamps and there specifications see: [Lighting](#) (📖 154).

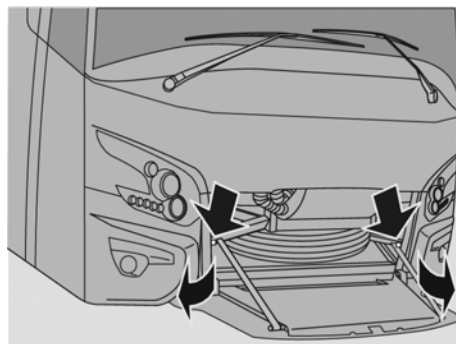

ILHa0010

Replacing headlamps

Open the spoiler flap handle (see [Spare wheel compartment handle](#) (📖 41)) and open the relevant fog light space by pulling on the handle.

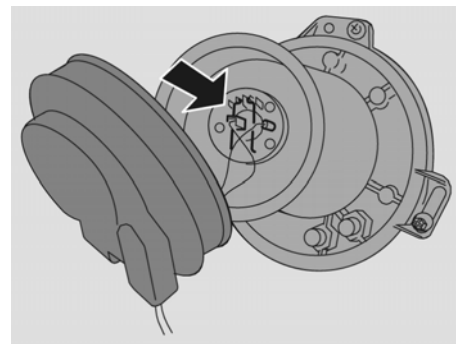

ILHh0048

Remove the protective cover on the light. Pull out the light plug. Unhook the spring. Replace the bulb.



Make sure that the lamp engages in the recess in the reflector.

Headlights driver's side.

The bulbs on the driver's side are replaced in the same way.

Xenon lamps

Provided the lamps are not switched on and off excessively, Xenon lamps have a

very long life span and the risk of lamp failure is extremely low.

However, if the bulbs are faulty, the vehicle can still be driven using the fog lights, but only if the local laws allow this.



Replacing xenon bulbs is a very specialized procedure and may only be carried out by highly trained technicians.

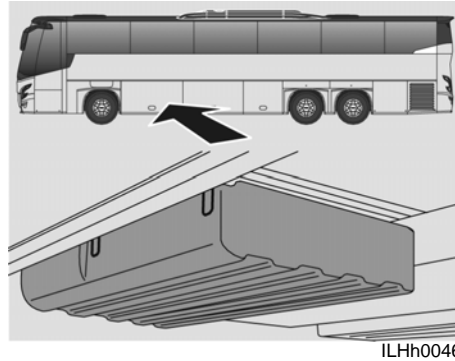

REPLACING FUSES

Electrical circuit diagrams

Location of the supplied binders with vehicle specific electrical diagrams and fuse-, and relay lists is shown above.

General information

If an electrical component does not work, this may be due to a fuse which has blown as a result of a temporary excessive load.

The vehicle's fuses are in four locations.

- One fuse box is at the front right luggage compartment.

- One fuse box is in the left luggage compartment. In this fuse box there are mostly fuses and relay's for options
- One fuse box is in the passenger compartment behind the air intake grilles in the ceiling at the middle of the coach. In this fuse box there are the fuses for the air fans of the climate system.



The air intake grille is fastened with Velcro.



Look in the fuse list supplied to see which fuse is to be checked.

The fuse lists are located in the electro boxes.

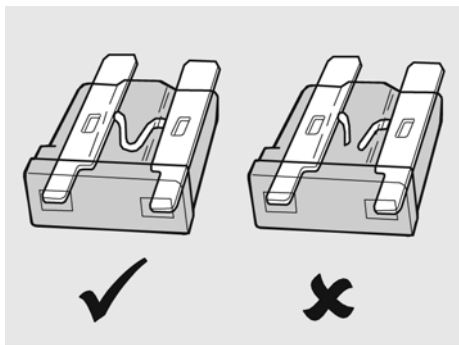

ILHh0034

Pull the fuse out in a straight line and look on the inside to see whether the wire loop has burnt out.

5

If necessary, fit a new fuse of the same colour and with the same amperage as the previous fuse. The amperage is stated on the fuse.



Never replace a faulty fuse with one of a higher capacity.

If fuses in the same location burn out repeatedly, there is a failure in the electrical installation and the vehicle must be taken to a workshop for inspection.

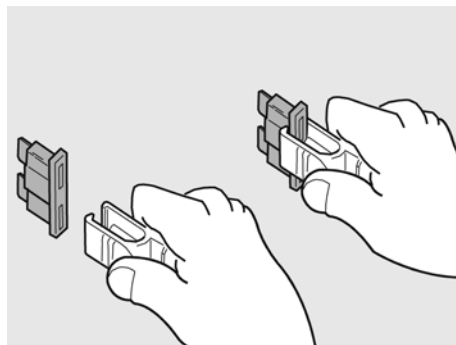

ILHh0035

Pincers are provided to make it easy to change a fuse.



Spare fuses are supplied with the tool-kit.



Do not forget to replace the pliers after use.

JUMP STARTING.

If the vehicle is started with the aid of separate batteries (24V approx) or with the help of another vehicle with its engine running (28V approx) the battery cables must not be removed.



Do not use a speed starter set to start the vehicle as this may damage the vehicle electronics.



Do not cause sparks, because that may cause the batteries to explode.



Prevent the two vehicles from touching each other.

Connect the start cable to the positive (+) battery clamp first and then to the negative (-) battery clamp. When removing the cables, remove the cable connected to the negative (-) clamp first before removing the cable connected to the positive (+) clamp. If the battery is fully discharged and the engine is running, it is important that the start cables are not removed immediately. To prevent damage to the electrical system due to voltage peaks, the engine must run for at least 3 minutes before the start cables are removed.

TOWING



Do not tow the vehicle whilst there are passengers onboard.

Safety

Always use a towing rod. Only in an emergency is it permitted to use an alternative means of towing. This may only be deviated from in an emergency situation.

Keep the speed to a maximum of 40 km/h in these circumstances.

Driving speed must always be matched to the conditions.



The drive shafts must always be uncoupled from the differential when towing over long distances to prevent damage to the gear box.

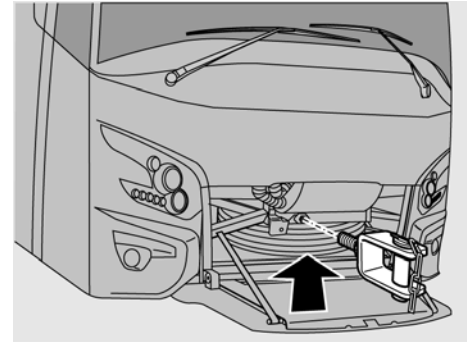

ILHz0008

Fitting towing eye

A towing eye is supplied with each coach. The towing eye is located with the on-board tool kit in the luggage compartment to the right behind the rear wheel.

The towing eye may be screwed into a socket behind the spoiler flap, or in the rear bumper, above the exhaust.



Screw the towing eye in as far as possible.

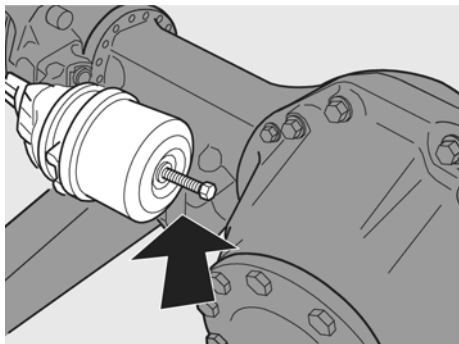

Releasing the parking brake

Start the engine and bring the brake system up to pressure.

5

If it is not possible to start the engine, the parking brake can be freed by two different methods.

- Place chocks in front of or behind the wheels and turn the bolts of both brake spring cylinders as far as possible to the left with the aid of a 24 mm spanner. The coach can now be towed. Restore the operation of the brake spring cylinders as quickly as possible, by turning the bolts as far as possible to the right setting them with a torque of 40-50 Nm.

ILHd0000

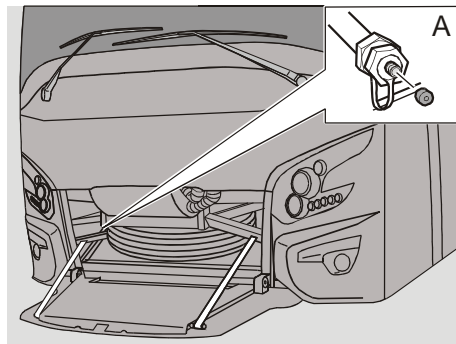

ILHi0010

- The second method of freeing the parking brake makes use of the emergency air connection, to which an air hose can be connected to import air from another source.



To release the parking brake, the system must be pressurized to a pressure of at least 6 bar.



To release the parking brake, the system must be pressurized to a pressure of at least 6 bar.



The maximum pressure in the parking brake must not be greater than 11 bar.



If the engine is not running the vehicle's steering will be heavy due to the lack of power steering.



Turn on the hazard warning lights before towing and attach a "Towing" sign to the vehicle which is being towed.

Towing with a damaged differential

Hoist the vehicle from the rear and block the steering wheel.

Tow-start



Vehicles with an automatic transmission may not be tow started.

If the vehicle must be towed to start the engine, the ignition key must be turned to position I.

When towing it may happen that the batteries are too low to allow the main

switch to be closed by the dashboard switch.

To prevent damage to the dynamos and regulator, main switch relay contacts 31 and 31a must be temporarily connected together (see drawing).

The main switch relay is located in the front of the right luggage compartment.

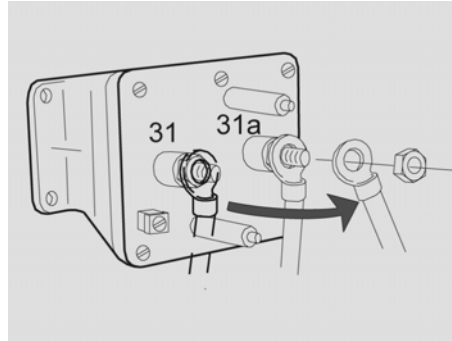

ILHh0033

- Remove the battery earth clamp.
- Connect together the master switch relay cables with a bolt.
- Reconnect the battery earth clamp.

The vehicle may now be towed to start the engine.

After the engine has run for a time and the batteries are sufficiently charged the master switch relay must be reconnected in the original configuration.

Proceed as follows:

- Switch off the engine.
- Remove the battery earth clamp.
- Restore master switch relay connections.
- Reconnect the battery earth clamp.

Towing other vehicles



The vehicle to be towed may not be heavier than 25 tonnes.

ITS-VDL

ITS-VDL deals with emergencies and strandings, free of charge, 24 hours a day, 365 days a year.

ITS-VDL can be contacted via the following telephone number: +31 (0)40 294 80 80.

The international code for the Netherlands is 00-31 from most EC countries.

If you contact ITS-VDL, you must provide the following information.

This information can be found in the vehicle registration documents and on the type plate in the entrance bay or behind the driver's seat.

Make sure you have this information with you when phoning:

- Vehicle type
- Year of construction
- Vehicle owner
- Chassis number
- Registration number
- Name of the workshop where the vehicle is serviced (home dealer).
- The exact location of the vehicle (ask somebody who knows the area).
- Telephone number which you can be reached at.
- The expected cause of the problem.
- Proof of guarantee
- ID card for identifying components.

If the home dealer is offering a payment guarantee for a repair, the invoice from the repairing dealer goes to the owner through the home dealer. This also applies to any VDL Bus & Coach spares supplied.

In this way the driver does not have to pay for any repairs and he can express in his own language what the cause of the breakdown is.

Once a driver has contacted ITS for assistance, he must not leave the place mentioned without first reporting this to ITS.

Spare parts delivery

In a number of countries the DAF dealer can supply both VDL Bus & Coach and DAF parts from stock.

6 IDENTIFICATION

VEHICLE IDENTIFICATION	129
ENGINE NUMBER	132
ENGINE IDENTIFICATION PLATE	132
PNEUMATIC CHARACTERISTIC DATA	133
DTCO IDENTIFICATION PLATE.....	134
PAINT IDENTIFICATION	134
KEY AND IDENTIFICATION NUMBERS	135
MASTER CARD	135

The identification plate is located on the left-hand side of the entrance bay or behind the driver's seat.

A	Company name
B	Type approval number
C	Chassis number
D	Commercial type name
E	Type
F	Maximum permitted axle loads for the country of acceptance (see the country code)
G	Maximum technically permissible axle loads (all countries)
H	Engine number
I	Engine capacity
J	Emission classification
K	Tyre type
L	Spare
M	Spare
N	Type/variant/version
O	Spare
P	Country of manufacture

A						H	
				D		I	
C			E			J	
	F	kg		G	kg	K	
	F0	kg		G0	kg	L	
1-	F1	kg	1-	G1	kg	M	
2-	F2	kg	2-	G2	kg	N	
3-	F3	kg	3-	G3	kg	O	
P							
VDL BUS & COACH							

ILHz0011

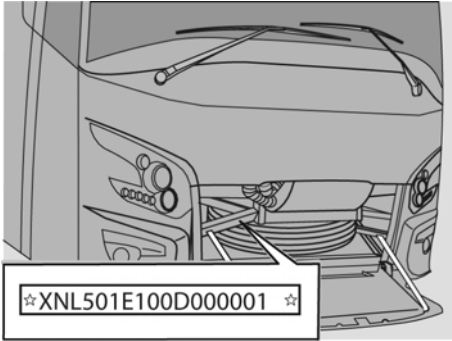

ILHf0002

Chassis number

The chassis number is constructed in accordance with the international V.I.N. standard (Vehicle Identification Number)

The last 8 figures of the chassis number form the VDL Bus & Coach chassis number. Always mention these 8 figures when communicating about the vehicle, e.g. when ordering parts.

For controlling authorities the chassis number is also imprinted in the chassis beam behind the spare wheel compartment flap.

Example: XNL501E100D000001

XNL	Company identity
501	Commercial description
E	Letter code for the axle configuration (E: 4 x 2.2 axles, of which one is driven)
1	Diesel engine
00	00
D	Production location code
000001	Serial number

Axle loads

The maximum axle loads as stated in sections C, D and E are distributed as follows:

blank	Total weight
0	Train weight (including trailer)
1	Axle load, front axle
2	Axle load, rear axle
3	Axle load, trailing axle
4	Spare

Country code

Stated here is the country the vehicle was produced for. The country codes of the Dutch approval body RDW are found here.

Type indication

Example: FHD2-122 410

FHD2	High version
122	Coach length in decimetres
410	engine (hp)

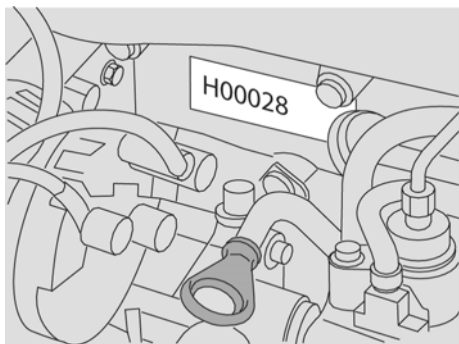

ILHJ0012

ENGINE NUMBER

PR engine

The engine number is stamped on the engine block at the same height as the generator.

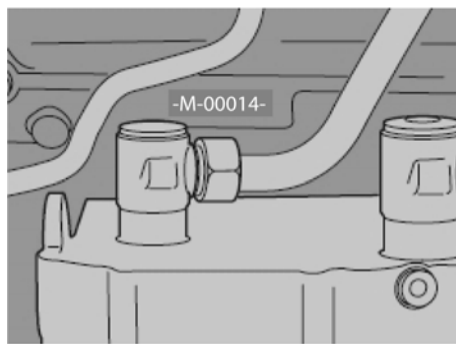

ILHJ0011

MX engine

The engine number is stamped on the engine block at the same height as the compressor.

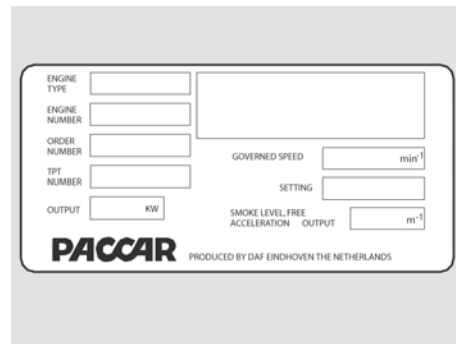

ILHJ0021

ENGINE IDENTIFICATION PLATE

The engine identification plate states various engine details, such as:

- Engine type
- Engine number
- Order number.
- TPT number.
- Output.
- Governed speed.
- Setting.
- Smoke level for free acceleration

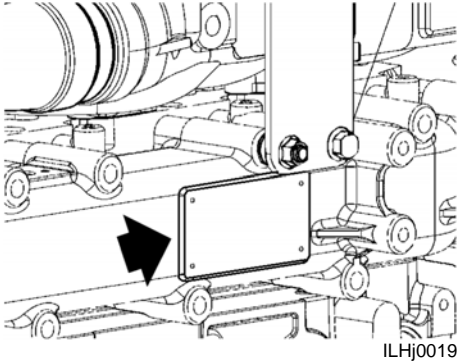

PR engine

The engine identification plate is fitted against the engine's inlet manifold.

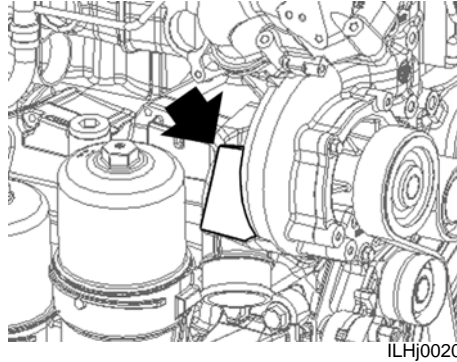

MX engine

The engine identification plate is fitted against the engine's water pump housing.

VDL Bus & Coach B.V.			Pneumatic characteristic data	
Compressor/unloader valve	Max. cut-out pressure = 12,8 bar	Min. cut-in pressure = 10,5 bar		
Four-circuit protection valve	Static closing pressure= circuit 1,2 > 6 bar circuit 3,4 > 4,5bar			
Minimum design pressure in the service braking system for calculation	8,0 bar			

ILHi0012

PNEUMATIC CHARACTERISTIC DATA

The plate with information concerning the air pressure properties is located behind the driver's seat.

The plate includes details of the pneumatic system.

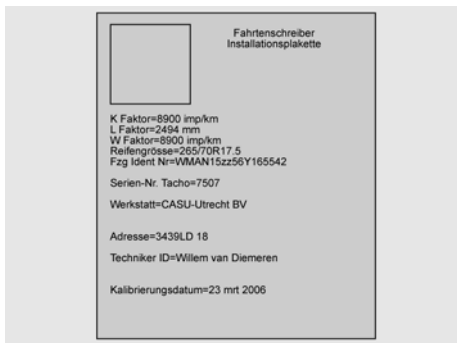

ILHz0015

DTCO IDENTIFICATION PLATE

The plate includes details of the DTCO and is located at the side window above the driver.

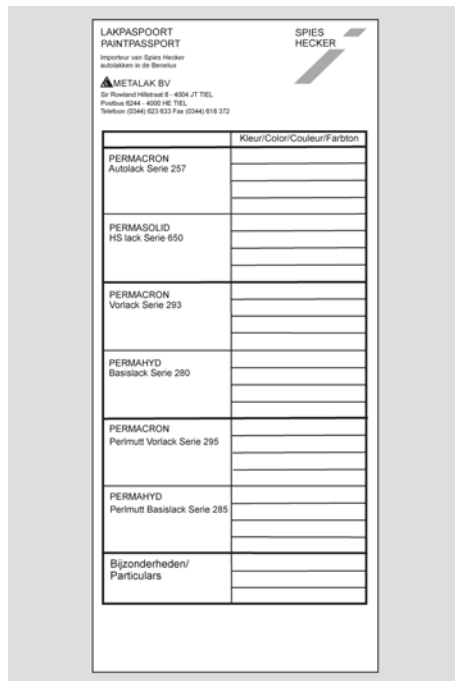

ILHz0034

PAINT IDENTIFICATION

The paint identification and paint supplier are indicated on a sticker on the inside of the driver's locker.

The most important information on this sticker is the international RAL numbers which enable paint of exactly the same colour to be ordered from any local paint supplier.

If possible VDL Bus & Coach always uses a RAL colour, unless the owner wants his own (company) colour. In these cases a code is mentioned which denotes the composition of that particular colour which remains available from VDL Bus & Coach. To avoid mistakes when ordering paint it is advisable always to include the chassis number along with the RAL numbers.

KEY AND IDENTIFICATION NUMBERS

A number of keys are supplied with each vehicle. When replacing, e.g. one boot lid lock, it is possible to order a new lock with the same lock number as the rest. Keys with a specific serial number can be supplied afterwards.



We strongly recommend you keep a record of the keys' serial numbers.



Identification numbers for the various items of equipment fitted to the coach can also be reported here.

	Key and identification number:
Contact switch	
Dashboard box	
Driver's locker	
Passenger door	
Middle door	
Emergency door	
Luggage flaps	
Engine cover	
Filler cap	
Safe	
Toilet	
toilet locker	
Refrigerator	
TV	
Video	
Radio	
CD player	
Navigation system	
Alarm system	

MASTER CARD

All important components of your vehicle and their identification numbers are listed on this card.



You must have the master card available when contacting ITS and when stranded.

7 TECHNICAL INFORMATION

ENGINE.....	139
WHEELS AND TYRES	139
REFERENCE BRAKING FORCES.....	141
EXTRAPOLATION PRESSURE.....	143
FLUID AND LUBRICANT SPECIFICATIONS.....	144
TOW BAR INFORMATION	150
COUPLING AND UNCOUPLING.....	152
ELECTRICAL COMPONENTS	154
VEHICLE LAYOUT	156

ENGINE

Make	DAF		
Type	PR 265U	MX 300U	MX 340U
Location	Vertically behind the rear axle		
Construction method	4-stroke diesel engine, direct injection, 6 cylinders in line, turbo and intercooler.		
Number of valves	24	24	
Bore x stroke	118 x 140	130 x 162	
Contents	9.2 litres	12.9 litres	
Compression ratio	17,5:1	16.5 :1	
Max. power	265 KW (360 hp) at 2,200 rpm	300 KW (410 hp) at 1,900 rpm	340 KW (460 hp) at 1,900 rpm
Unloaded engine speed	Approx. 600 rpm	Approx. 550 rpm	
Maximum engine speed loaded	2200 rpm	1,900 rpm	
Max. torque	1275 Nm between 1,200 – 1,700 rpm	2,000 Nm between 1,000 – 1,500 rpm	2300 Nm between 1,000 – 1,500 rpm
Speed limiter	Via DMCI engine management		
Emission	U1 = Euro 5 / U2 = EEV / U3 = Euro 5 HD		

WHEELS AND TYRES

Tyre pressure

The stated tyre pressures are suitable for the stated maximum axle loads, provided the vehicle is used under normal conditions. For other conditions, see the information provided by the tyre manufacturer.

Tyre size	Pressure (bar)		
	Front axle	Rear axle	Trailing axle
295/80 R 22.5	8.5	7,75	7,75

Torque

The wheel nut torque 600Nm ± 3%.



Retighten the wheel nuts after 100 km.

Winter tyres

The maximum speed specified by the tyre manufacturer must not be exceeded.

When determining the correct winter tyres, the specified load index and speed index of the tyres must be observed.

When using winter tyres, we recommend that you observe the guidelines, assembly instructions and tyre pressures specified by the tyre manufacturer.

Snow chains

As the driver of a vehicle on wintry roads, you must observe the legal regulations, such as road traffic sign no. 268.



This sign makes the use of snow chains compulsory on a snowy or slippery road surface.

 **Snow chains may only be used in combination with the following tyres: Michelin XZA2 or Michelin XD Coach.**

The other specifications are:

- Maximum height of the chain is 15mm.
- Maximum speed when driving with snow chains is 40km/h.
- The combination Michelin XD coach / snow chains is not allowed on the front axle.
- You may only drive on normal driving height.
- If there are chains mounted on the front axle, maximum steering is only allowed while driving slower than 10 km/h.
- The snow chains have to be mounted according to the instructions of the manufacturer.

 **Do not use snow chains unnecessarily when there is no snow on the road surface, because that will wear down the snow chains and the tyres very quickly.**

REFERENCE BRAKING FORCES

The reference values in the table have been intended for stipulating the braking deceleration using a roller test stand.

Reference values DISC brakes (N) ^a								
Type of brake	Disc	Disc	Disc	Disc	Disc ^b	Disc	Disc	Disc
Brake cylinder	27"	24"	22"	20"	18"	16"	14"	12"
Design axle torque	5569	4822	4415	4041	3702	3362	2819	2411
Front axle	X	X	---	---	---	---	---	---
Drive shaft	---	X	X	---	---	---	---	---
Trailing axle	---	---	---	X	---	X	X	X

Technical information

Pressure (bar)	0.0	0	0	0	0	0	0	0	0
	0.5	0	0	0	0	0	0	0	0
	1.0	4,000	3,600	3,100	2,500	0	0	0	0
	1.5	8,000	7,100	6,100	5,000	3,700	2,400	2,000	1,800
	2.0	11,900	10,700	9,200	7,600	6,200	4,800	4,000	3,600
	2.5	15,900	14,300	12,300	10,100	8,600	7,200	6,000	5,400
	3.0	19,900	17,800		12,600	11,100	9,600	8,000	7,200
	3.5	23,900	21,400	18,400	15,100	13,500	12,000	10,000	9,000
	4.0	27,900	25,000	21,500	17,600	16,000	14,400	12,000	10,800
	4.5	31,800	28,500	24,500	20,200	18,500	16,800	14,000	12,600
	5.0	35,800	32,100	27,600	22,700	20,900	19,200	16,000	14,400
	5.5	39,800	35,700	30,700	25,200	23,400	21,600	18,000	16,200
	6.0	43,800	39,200	33,700	27,700	25,800	24,000	20,000	18,000
	6.5	47,800	42,800	36,800		28,400	26,400	22,000	19,800
	7.0	51,700	46,400	39,900			28,700	24,000	
	7.5	55,700	49,900	43,000			31,100	26,000	
8.0	59,700	53,500	46,000						

- a. Reference Values are Axle values corresponding with $a=5 \text{ m/s}^2$, in the case of 22,5 inch wheels
- b. Derived values

EXTRAPOLATION PRESSURE

Type	Engine	of	To	-	P2	Pmax		Extrapolation pressure (Pex)		
						Nominal [bar]	Tolerance [bar]	Axle 1 [bar]	Axle 2 [bar]	Axle 3 [bar]
Futura	Euro 5 + EBS	11104	-	2-axle	8,8	10	± 0,5	8,0	8,0	-
	Euro 5 + EBS	11104	-	3-axle	8,8	10	± 0,5	8,0	8,0	8,0

P2 = Cut-in pressure (minimum)

Pmax = Cut-out pressure (nominal / maximum)

Pex = Extrapolation pressure (guaranteed pressure in brake cylinder)

FLUID AND LUBRICANT SPECIFICATIONS

General information

In order to comply with the warranty terms and to guarantee the durability, safety and reliability of VDL Bus & Coach products, it is essential that the correct lubricants, coolant and fuel are used and that they are changed in accordance with the specified changing intervals.

Never use additives with lubricants, coolant and fuel, except in the cases specified by VDL Bus & Coach.

Always follow the safety instructions below and the instructions that are supplied with the product.

Ask your lubricant and fuel supplier(s) whether the products they supply comply with the VDL Bus & Coach specifications.

In the following cases, no claims may be made against the VDL Bus & Coach warranty:

- Using oil of a lower grade than specified.
- Using oil of a lower/higher viscosity than specified.
- Exceeding the changing interval.
- Using lubricant, fuel, AdBlue or coolant which does not meet the requirements set by VDL Bus & Coach.

Safety



The fluids in the vehicle can cause serious injury and/or serious health problems in the event of bodily contact.



Avoid bodily contact with fuel, lubricants, coolant, battery acid and AdBlue.

In the event of bodily contact, always observe the following instructions:

- In the event of skin contact: remove the substance with paper or a cloth and wash with soap and water. If the irritation persists, contact a doctor.
- In the event of contact with the eyes: remove the substance with a soft cloth and rinse with water. If the irritation persists, contact a doctor.
- If swallowed: Do NOT induce vomiting. Rinse the mouth, drink two glasses of water and contact a doctor.
- In the event of inhalation: get some fresh air and take a rest.

Battery acid

In the event of skin contact: rinse the skin with plenty of water.

If redness or pain persists, contact a doctor. Remove any contaminated clothes and rinse them with water.

In the event of contact with the eyes: wash the eyes for at least 15 minutes with plenty of water and contact a doctor.

If swallowed: Do NOT induce vomiting. Rinse the mouth, drink two glasses of water and contact a doctor.

In the event of inhalation: get some fresh air and take a rest.

AdBlue

Storage instructions

- Only use original storage tanks.
- Store in a cool, dry, ventilated area.
- Protect storage tanks against freezing.
- Observe the manufacturer's storage and usage instructions.

Safety instructions

- Avoid bodily contact.
- In the event of skin contact: rinse with plenty of water.
- In the event of contact with the eyes: rinse with plenty of water for at least 15 minutes and seek medical assistance.
- If swallowed: rinse your mouth with plenty of water. Do not induce vomiting.
- In the event of inhalation: get some fresh air and take a rest. Seek medical assistance.
- Use in a ventilated area.

Procedure after a spillage

- Rinse with plenty of water.



AdBlue is neither toxic nor harmful to the environment.

Engine

Type	DAF PR _x	DAF MX
Engine oil specifications	ACEA E6 / .. W-40	
Volume of the lubricating oil system, including the oil filter	approx. 33 litres	approx. 39 litres
Sump capacity, maximum level	approx. 26 litres	approx. 33 litres
Sump capacity, minimum level	approx. 18 litres	approx. 25 litres



Coolant is poisonous. Protect the skin and eyes.



Coolant is harmful to the environment and must, therefore, be processed as industrial waste after use.

Cooling system

Coolant specifications	DAF 74002/BTPS 606A/DCEA 615
Cooling/heating system volume	between 65 and 100 litres, depending on the model.



The sticker on the coolant reservoir indicates the coolant which is used in the system.



Never mix coolant with different specifications.



Never fill with propylene glycol, since ethylene and propylene glycol are incompatible.

Air conditioning

Type	DENSO
Compressor type	10PA20
Lubrication oil specification	ND-oil 8 / PAG 46
Total capacity per cycle	140 cc (for the compressor) +300 cc (for the reservoir)
Coolant R134a Cycle 1 (right-hand side, including air conditioning front box)	Approx. 2.5 kg
Coolant R134a Cycle 2 (left-hand side, excluding air conditioning front box)	Approx. 2.2 kg

Gearbox

Type	GO 170/210/ 230	ZF Ecomat	ZF AS tronic
Lubricant specifications	75W90 synthetic API GL4 (MB235.11)	ZF Ecofluid A + class 14E (ZF TE-ML 14)	ZF Ecofluid M class 02E (ZF TE-ML 02)
Volume when changing oil	approx. 12.5 litres	approx. 18 litres	approx. 12 litres
Number of gears	6	6	12

Retarder

Type	Voith R115E	ZF intarder
Lubricant specifications	SAE 75W80 synthetic (Voith retarder 153.000831xx)	integrated in the automatic gear-box
Volume when changing	approx. 7 litres	

Shifting control

Type	SGS	Automatic
Operation	Power-assisted two-cable shifting system	Electro-pneumatic

Clutch

Type	Single dry plate connection
Diameter	430 mm
Operation	Hydraulic
Fluid specification	Brake fluid DOT4

Front / trailing axle

Type	ZF RL 75 E/ZF RL 75 A
Lubricant specifications	Lithium soap grease
Hub	(NLGI class 2, grease type KP2K-30)
Lubricant specifications	Lithium soap grease
Grease nipples	(NLGI class 2, grease type KP2K-30)

Rear axle

Type	ZF A-132
Axle bridge lubricant specification	SAE 80W-90 / API GL-5
Axle bridge capacity	approx. 16 litre
Lubricant specifications	(NLGI class 2, grease type KP2K-30)
Hub	

Steering mechanism

Type	ZF 8098
Fluid specification	ATF Type Shell Donax TM
Contents	approx. 10 litre
Wheel turning angle	60°
Gear ratio	1:22.2/26.2

Hydraulic drive

Fan	
Fluid specification	ATF type Shell Donax TZ (ZF TE-ML 14E)
Contents	approx. 9 litre

Fuel

Diesel or a diesel mixture must meet the EN 590 specifications. At extremely low temperatures, a maximum of 20% petroleum or a viscosity improver may be added in emergency situations, such as when stranded. If this is NOT LEGALLY PERMITTED, then a maximum of 20% unleaded petrol can be added.

Only non-foaming fuel may be used when using a quick-refuelling unit.



The sulphur content of the diesel must be less than 50 ppm. If the sulphur content is greater than 50 ppm, then the oil changing interval must be altered accordingly.

Fuel must have a lubricating quality which meets the standard given below (lubricity standard):

Test method: HFRR according to norm CEC-F-06-A96

Test value: < 460 µm



Switch off the engine and switch off the pre-heater before filling fuel tanks.

Capacity of the fuel tank: 1 x 500 litre approx + 1 x 387 litre (optional).

Urea (AdBlue)

Urea (AdBlue) must comply with specification according DIN70070.

Capacity of the urea tank: approx. 60 litre



AdBlue is neither toxic nor harmful to the environment.

Biodiesel



Contact your VDL Bus & Coach service dealer for information concerning the use of alternative fuels (e.g. biodiesel) and any consequences this may have.

Biodiesel must comply with the EN 14214 specifications.

Contact your VDL Bus & Coach service dealer for the conditions placed on using a mixture with more than 7% biodiesel.

Depending on its origin, biodiesel which satisfies EN 14214 may contain chemical elements which may have a negative effect on the exhaust gas after treatment system.

Therefore, it is the user's responsibility to carefully choose his biodiesel supplier.

Comment

Biodiesel has solvent properties so that changing from diesel to biodiesel may cause deposits in the fuel system to come loose and the filter to become blocked. When changing from diesel to biodiesel, it is recommended to check the filters after 1 or 2 refuellings and to replace any blocked filters. Biodiesel can cause problems at low temperatures, such as blockages to filters.

The use of **biodiesel** requires extra checks (see "Overview of the monthly checks when using biodiesel", [Overview of the monthly inspections when using biodiesel](#) (📖 96)).

Capacity of the fuel tank: approximately 1 x 500 litres + 1 x 387 litres (optional)

TOW BAR INFORMATION

Below is an overview of the approved tow bars which can be fitted and used with Futura FHD2 vehicles from Ch 10320501.

Type	Manufacturer	Type	Approval number	Trailer weight	D (kN)	S (kg)	Only in combination with a crossbeam and spacer (VDL Bus & Coach part no.)
Coupling ball	MCB	50221	e4*94/20*2989*00 correction 01	a	31.0	350	300351 / 282448
Coupling ball	Oris	D125/1	e1*94/20*0019*01	A	25.0	120	300351 / 283144
Coupling quick release system	Rockinger	Variobloc (assembly)	e1 00-0044	A	25.0 (combined with Oris D125/1)	120	300351
Trailer coupling	Rockinger	243B35000	e1 00-0051	A	30	350	300351 / 283145
Trailer coupling	Carspeed	Compact 40	e2*94/20*1058*00	A	30 ^(b)	350 ^(c)	300351 / 283131
Coupling quick release system	Rockinger	Variobloc (assembly)	e1 00-0044	A	30 (combined with Rockinger 243B11000)	250	300351 / 283144

- a. Depending on the vehicle weight
- b. Max 30 kN (towing bracket is permitted for 54 kN)
- c. Max 350 kg (towing bracket is permitted for 700kg)

By using the following two formula's it's possible to calculate the technically permissible mass of the trailer:

For mechanical coupling devices unsuitable for transmitting vertical bearing loads the value "D" is (this does not apply to centre axle trailers):

$$D=(9,81 \times T \times R)/(T+R) \text{ (kN)}$$

For mechanical coupling devices suitable for centre axle trailers the value "D" is not mentioned in the table:

hSee for "Dc" the manufacturer plate of the coupling device.

$$Dc=(9,81 \times T \times C)/(T+C) \text{ (kN)}$$

- T =** Technically permissible maximum mass in tonnes of the towing vehicle including, if necessary, the vertical load of a centre axle trailer.
- R =** Technically permissible maximum mass in tonnes of the full trailer with drawbar free to move in the vertical plane or of the semi trailer.
- C =** Sum of the axle loads of the centre axle trailer carrying maximum permissible load, in tonnes.

COUPLING AND UNCOUPLING

	Overview of combination possibilities			
	Trailer without ABS (correctly connected)	Trailer with ABS (correctly connected)	Trailer with EBS (correctly connected)	Trailer with EBS (5-pin ABS wiring harness instead of 7-pin EBS wiring harness)
Pulling vehicle without ABS	Load-dependent brake control (mechanically active). No ABS control.	Load-dependent brake control (mechanically active). No ABS control.	No load-dependent brake control. No ABS control. nForbidden by law.	No load-dependent brake control. No ABS control. nForbidden by law.
Pulling vehicle with ABS	Load-dependent brake control (mechanically active). No ABS control.	Load-dependent brake control (mechanically active). ABS control active.	Load-dependent brake control (electronically active). ABS control active.	Load-dependent brake control (electronically active). ABS control active.
Pulling vehicle with EBS	Load-dependent brake control (mechanically active). No ABS control.	Load-dependent brake control (mechanically active). ABS control active.	Load-dependent brake control (electronically active). ABS control active. CAN communication.	Load-dependent brake control (electronically active). ABS control active.

A trailer with ABS is fitted with an anti-lock braking system

A trailer with EBS is fitted with an electronically controlled brake system, which incorporates ABS.



Both versions are connected by means of a special plug to the extra socket of the ABS/EBS system on the prime mover.

If this plug is not connected, a yellow warning will appear on the display.

7



Consequences of not connecting an EBS trailer to a pulling vehicle with EBS via the ABS/EBS plug:
No load-dependent brake control. No ABS (depends on the version of the EBS system on the trailer). No EBS control.
Always the full braking force, regardless of the load.

	ABS EBS	ABS	EBS
	✓	✓	✗
	✓	✓	✓
	✓	✓	✓

ILHI0007

ELECTRICAL COMPONENTS

Generators

Type	Alternating current
Contents	28 V x 110 A

Batteries

number	2
Voltage	12 V
Contents	230 Ah

Windscreen wiper system

Wiper blade length	100 cm
Reservoir capacity	14 litres

Tow bar junction box

D+ connection	Maximum 2 A
Constant supply	Maximum 7.5 A

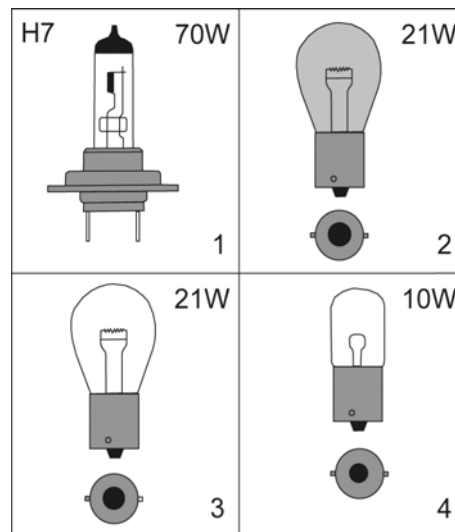

ILHh0043

Lighting

As an optional extra, xenon lighting is available for the main beam and dipped beam.



Replacing xenon bulbs is a highly skilled procedure and should only be carried out by suitably trained technicians.

		number	Type	Contents
A	Dipped beam (H7)	2	1/xenon	70 W
B	Main beam (H7)	2	1/xenon	70 W
C	Fog lamps (H7)	2	1	70 W
D	Day driving lights	10	LED	--
E	Front indicator lamp	2	2	21 W
F	Side indicator lamp	2	LED	--
G	Rear indicator lamp	2	LED	--
H	Rear lamp	2	LED	--
I	Brake light	2	LED	--
J	Rear fog lamp	1	LED	--
K	Reversing lamp	2	LED	--
M	Side profile lamps	12/14	LED	--
N	Top lighting	4	LED	--
O	Registration plate lighting	2	LED	--
	Luggage space lighting	8	4	10 W
	Engine compartment lighting	1	3	21 W

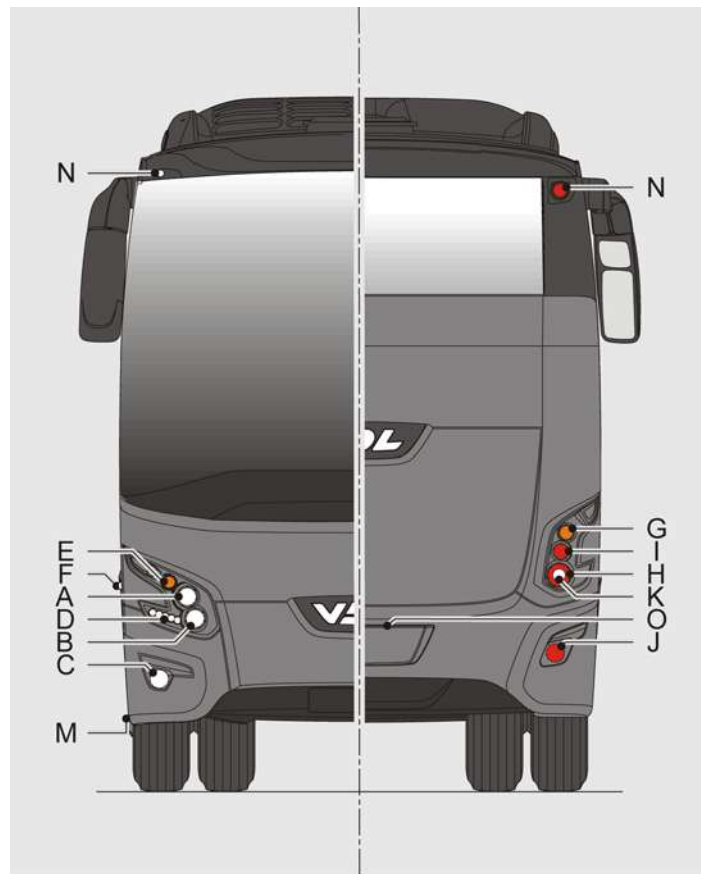

ILHa0005

VEHICLE LAYOUT

Specified weights and dimensions are given in the following table. The actual weights (in particular) of the vehicles can vary from these specifications depending on the options installed. The vehicles are weighed before delivery and a copy of the weight registration form stating the actual empty weight is added to the delivery documents. Weights are expressed in kilograms and dimensions are expressed in millimetres.

 **If optional extras are fitted, the vehicle height may differ from the value stated below and/or mentioned on the sticker in your vehicle.**

	FHD2122	FHD2129	FHD2131	FHD2139	FHD2148
Total length	12195	12875	13145	13945	14845
Total height including roof unit (A)	3700	3700	3700	3700	3700
Total width (B)	2550	2550	2550	2550	2540
Rear overhang (C)	3340	3340	2790	3210	3210
Wheelbase (D)	6150	6830	6150	6530	7430
Front overhang (E)	2705	2705	2705	2705	2705
Wheelbase (F)	-	-	1500	1500	1500
Interior height	1920	1920	1920	1920	1920
Front entry step height	342	342	342	342	342
Centre entry step height	368	368	368	370	370
Turning circle	20528	22096	20566	21440	23480
Maximum front axle load	7100	7100	7100	7100	7100
Maximum rear axle load	12000	12000	12000	12000	100
Maximum trailing axle load	-	-	6200	6200	6200
Maximum total weight	19100	19100	25300	25300	25300
Luggage compartment capacity	8.7 m ³	10.2 m ³	8.7 m ³	9.4 m ³	11.2 m ³

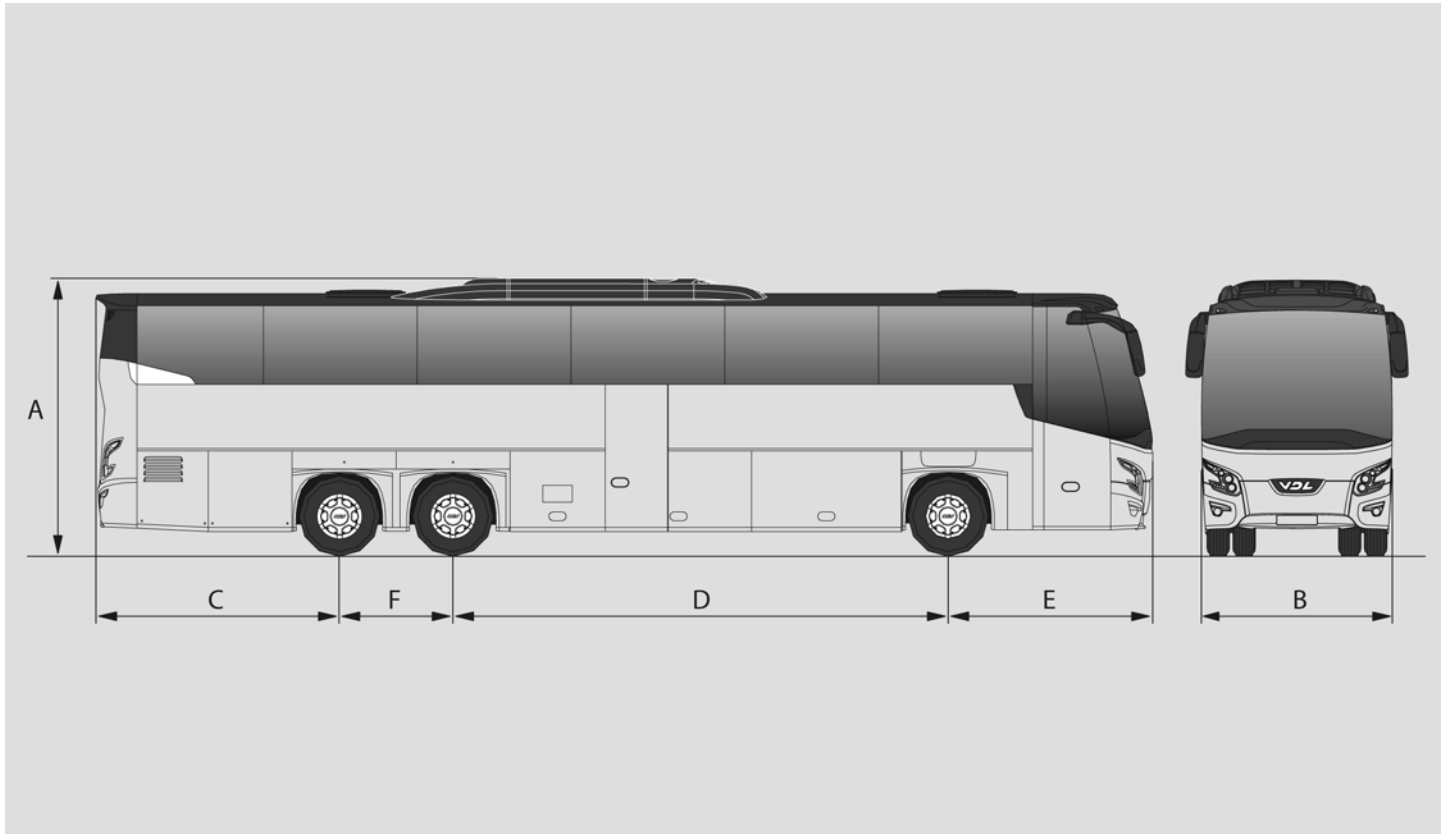

A		
ABS system	116	
Accelerator pedal	45	
AdBlue	145	
AdBlue legal minimum level	10	
AdBlue level	9	
Additional electric/electronic equipment	7	
Air conditioning system	16	
Air filter	92	
Air leaks	13	
Air suspension (ECAS)	67	
Anti-tilt system	68	
Audio	41	
	-Emergency operation	114
	Clock	38
	Clutch	11
	Clutch fluid	93
	Clutch pedal	34
	Component delivery	126
	Contact switch	24
	Coolant level	90
	Coolant temperature gauge	38
	Cooling system	146
	Corner light	30
	Cruise control	39

D	
Destination indicator lighting	41
Display	38
-Brightness adjustment	38
-Clock/trip meter	38
-Descriptions	54
-Messages	50
Driver and hostess ventilation fan	31
Driver's compartment and hostess lighting	44
Driver's seat	34
Driver's sleeping compartment	65
Drivers storage compartment	23
DTCO identification plate	134

E	
Earth switch	6

Electrical circuit diagrams	121
Electrically operated driver's side window	31
Electrically operated driver's screen	31, 32
Emergency hammers	78
Emergency operation	
-Luggage hatches	76
-Sleeping compartment hatch	75
Emergency procedures	79
Engine brake	33
Engine cover	19
Engine number	132
- MX engine	132
- PR engine	132
Engine oil level check, manually	88
Engine oil level electronically	87
Engine stop button	13
ESC (Electronic Stability Control)	12
Extrapolation pressures	143

F	
Fire extinguisher	4, 77
First-aid kit	5, 78
Fluid and lubricant specifications	144
Fog lamp front	31
Fog lamp rear	31
Fuel	144
Fuel gauge	38
Fuel lid	21

C	
Central dashboard switches	43
Chassis number	131
Climate system	

G	
Gear shifting	
-GO-210-230 gearbox	46
-ZF AS Tronic automatic gearbox	46
Gearbox	
- lubricant specifications	147
General tips	9
H	
Hand gas	40
Hazard warning lights	78
hazard warning triangle	78
Headlight washers	29
Hostess seat	23
Hydraulic drive fluid	91
I	
Inflating a tyre	119
Inspection lamp connection	106
Inspection lamp plug	107
Instructions for driving with a trailing axle	70
Instrument panel	37
Intercom installation	65
ITS-VDL	126
J	
Jack points	118
K	
Kitchen	67
L	
Left roller blind	43, 44
Left-hand combination switch	29
Luggage	5
Luggage flaps	20
Luggage flaps right	45
M	
Maintenance	
- Before the winter	97
- Weekly checks	91
-checklist	84
-Daily checks	87
-Exterior	99
-Interior	101
-When winter is over	99
Master card	135
Mirror adjustment	23
Mirrors	69
Mobile telephones	7
N	
Navigation system	45, 67
Night illumination	44
Night-lights/Passenger's reading lamps	31, 32

O	
Odometer	37
On-board tool kit	106
Option	30
Original VDL Bus & Coach parts	8
P	
Paint identification	134, 135
Parking brake	24
Parking/dipped lights	30
Passenger door	19, 43
Passenger fixation nuts	62
Passenger reading lights	44
Passenger seats	62
Personal service units	64
Pneumatic suspension leak	116
Poly V-belt	
- replacing, PR engine	109
Power steering fluid	91
Pre-heater	9
R	
Radiator	93
Raising and kneeling, rear	31
Raising/kneeling	68
Refrigerator	45
Releasing the parking brake	124
Replacing air-conditioning belts	108
Replacing fuses	121

Replacing light bulbs	120
-Headlights	120
xenon lamps	120
Replacing the air conditioning belt	110
Rev counter	38
Retarder	40
Right hand combination switch	39
Right roller blind	43
Right/fixed trailing axle wheels	32
Roof hatches	73
Roof unit dust filters	94
Running in	10

S

Safety instructions	4
Safety vest	4
Seat belts	77
Seats mountings with quick connection system	63
Service documentation reply form	1
Snow chains	140
Spare wheel	117
Spare wheel compartment handle	41
Speed limiter	13
Switches with no fixed location	41
Switching off engine	13
System voltage	6
Starting procedure	11
Starting with the aid of auxiliary batteries	122

Starting the vehicle using an auxiliary starting device	6
Steering mechanism	68
Steering wheel adjustments	38
Stopping/Parking	12

T

Tachograph	
- DTCO	42
Toilet	66
Top lights	41
Touching up paintwork	100
Tow hook junction box	154
Towing	123
Towing bracket data	150
Towing eye	123
Trailing axle relief	32
Transformer	41
Transmitters	7
Trip meter	38
Tyre pressure	139

U

Urea (AdBlue)	149
---------------	-----

V

V-belt	
- replacing, PR engine	107
- tension, adjusting for a PR engine	109
Vehicle dimensions	156

Vehicle identification	129
Ventilation grille	41

W

Warning light	
-ABS	37
-ECAS control symbols	67
-Indicators	37
-Main beam	37
-Parking brake	38
-Priority warning	37
-Priority warning 1	37
-Retarder	37
-Tachograph	37
-Trailer indicator	37
Warning symbols	4
Warning triangle	4
Warranty conditions	8
Water system	97
Welding	5
Wheel nuts	10
Wheels and tyres	116, 139
Windscreen washer fluid	92
Winter conditions	5
Winter tyres	139

DOCUMENTATION REPLY FORM

If you have any suggestions and/or comments concerning this manual or if you find any faults, please fill out this form and send it to:

VDL Bus & Coach Training and Documentation P.O. box 645 5550 AP Valkenswaard The Netherlands Fax: +31 (0)40 2084499		Company name : Name : Signature :	
Chassis number		
Applicable document order number:	Version:	
Type of document: <i>(set marker if applicable)</i>	Driver <input type="checkbox"/>	Climate <input type="checkbox"/>	
	Maintenance <input type="checkbox"/>	Electrical diagrams <input type="checkbox"/>	
	Workshop <input type="checkbox"/>	Training <input type="checkbox"/>	
	Parts <input type="checkbox"/>	Others <input type="checkbox"/>	
Kind of inaccuracy <i>(set marker if applicable)</i>	Linguistic (Definition) not correct	Mistake in technical data (values)	Images
	<input type="checkbox"/>	<input type="checkbox"/>	<input type="checkbox"/>
Additional information <i>(text, page number, etc.)</i>		
		
		
		

VDL Bus & Coach will take your report seriously and, if necessary, we directly make an update in the document.